

# Application Note: Strategies for Handling Moisture-Sensitive Sulfamoyl Chloride Intermediates

**Author:** BenchChem Technical Support Team. **Date:** May 2026

## Compound of Interest

Compound Name: *N*-(piperidin-2-ylmethyl)sulfamide

CAS No.: 1000931-64-5

Cat. No.: B1649445

[Get Quote](#)

) in medicinal chemistry workflows.

## Executive Summary

Sulfamoyl chlorides (

) are critical electrophilic linchpins in the synthesis of sulfonamides, sulfamides, and sulfamates. However, their utility is often compromised by their susceptibility to hydrolytic degradation and thermal instability. Unlike their carbon-bound analogs (sulfonyl chlorides,

), sulfamoyl chlorides possess a nitrogen-sulfur bond that influences their electronic stability and reactivity profile.

This guide provides a field-validated framework for handling these intermediates. By shifting from "isolation-first" to "telescoping-first" methodologies and strictly controlling moisture ingress, researchers can significantly improve yields and reproducibility.

## Mechanistic Foundation: The Instability Factor

To handle sulfamoyl chlorides effectively, one must understand their degradation pathway. The primary failure mode is nucleophilic attack by water at the sulfur center, leading to the formation of the corresponding sulfamic acid, which is often unstable and complicates purification.

## Hydrolysis Mechanism

The hydrolysis of sulfamoyl chlorides generally follows an

-like mechanism at the sulfur atom, though steric bulk on the nitrogen can shift this toward an -like dissociative pathway.

- The Driver: The highly electrophilic sulfur atom, flanked by two oxygens and a chlorine, is a "hard" electrophile.[1]
- The Failure: Trace water acts as a nucleophile. The resulting byproduct can autocatalyze further decomposition or react with the amine starting material to form unreactive salts.

## Visualization: Competing Pathways

The following diagram illustrates the kinetic competition between the desired sulfonamide formation and the hydrolytic degradation.

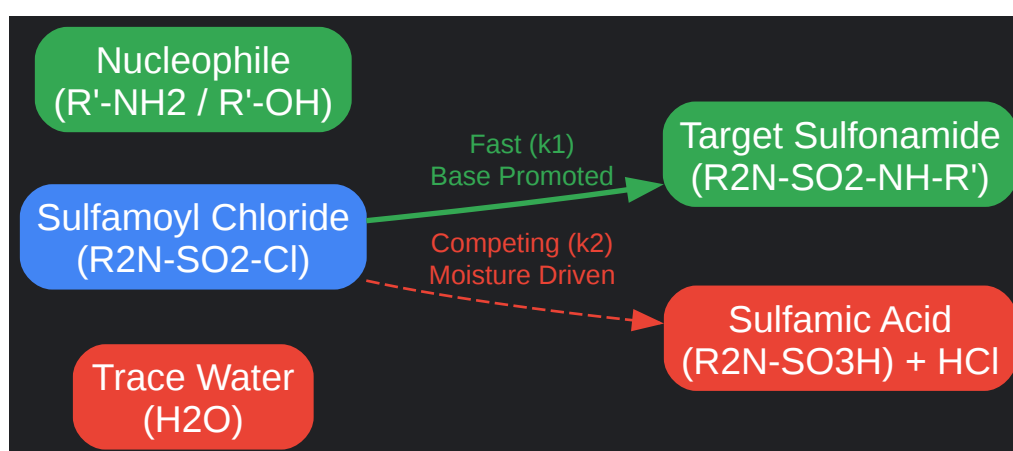

[Click to download full resolution via product page](#)

Figure 1: Kinetic competition between productive coupling and hydrolytic degradation. Minimizing

(hydrolysis) requires strict exclusion of water, as

(coupling) competes for the same electrophilic sulfur center.

## Protocol A: Synthesis via Sulfuryl Chloride ( )

Standard method for generating dialkylsulfamoyl chlorides.

Safety Warning: This reaction evolves significant quantities of

gas.[2] Perform only in a well-ventilated fume hood. Sulfuryl chloride is corrosive and reacts violently with water.[3]

### Reagents & Equipment[1][5][6]

- Amine ( ): 1.0 equiv.
- Sulfuryl Chloride ( ): 1.2 – 1.5 equiv.
- Solvent: Anhydrous DCM or Acetonitrile (MeCN).
- Base (Optional): Triethylamine (TEA) or DIPEA (if salt is not desired).
- Equipment: Schlenk flask, addition funnel, line, caustic scrubber for

### Step-by-Step Methodology

- Setup: Flame-dry a 2-neck round-bottom flask (RBF) and cool under a stream of dry
- Charging: Add

(1.2 equiv) and anhydrous DCM (5-10 volumes). Cool the solution to  $-10^{\circ}\text{C}$  to  $0^{\circ}\text{C}$ .

- Rationale: Low temperature controls the exothermic addition and suppresses side reactions (e.g., chlorination of alkyl chains).
- Addition: Dissolve the amine (1.0 equiv) and TEA (1.1 equiv) in DCM. Add this solution dropwise to the solution over 30–60 minutes.
  - Critical: Always add the amine to the sulfonyl chloride, not vice-versa. This ensures the electrophile ( ) is in excess, preventing the formation of symmetrical sulfamides ( ).
- Reaction: Allow to warm to room temperature (RT) and stir for 2–4 hours. Monitor by TLC or crude NMR (see Section 6).
- Workup (Isolation Path):
  - Concentrate the mixture under reduced pressure to remove excess and solvent.
  - Note: Do not use a water wash unless the product is known to be stable. For unstable intermediates, proceed immediately to Protocol B (Telescoping).

## Protocol B: The "Telescoping" Strategy (Recommended)

Best practice for moisture-sensitive intermediates.

Isolation of sulfamoyl chlorides often leads to degradation during concentration or exposure to ambient humidity. Telescoping (using the crude solution directly) is the superior approach.

## Workflow Logic

- Generate the sulfamoyl chloride (Protocol A).
- Purge excess volatile reagents ( , ).
- React immediately with the target nucleophile.

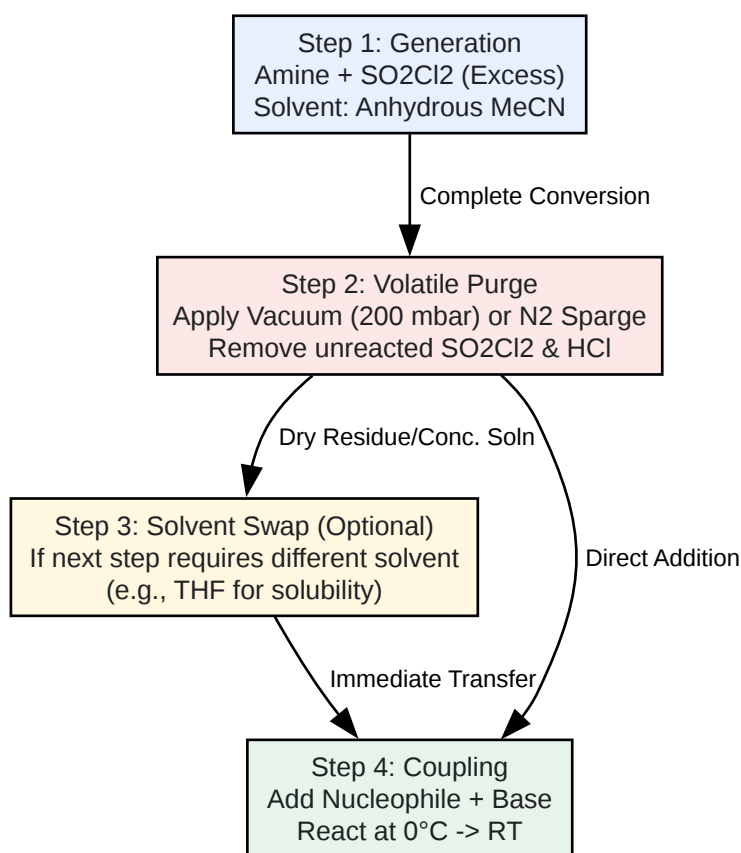

[Click to download full resolution via product page](#)

Figure 2: Telescoping workflow. Step 2 is the critical control point; failure to remove excess will result in the nucleophile reacting with the reagent rather than the intermediate.

## Detailed Protocol

- Generation: Perform Protocol A (Steps 1–4) in Acetonitrile (MeCN).

- Purge: Connect the flask to a vacuum manifold. Gently reduce pressure (down to ~100–200 mbar) for 15 minutes at RT to pull off excess

and dissolved

.

- Tip: Do not concentrate to complete dryness if the intermediate is thermally unstable. Leave as a concentrated solution.
- Coupling:
  - Prepare a separate solution of your Nucleophile (e.g., Aniline, Alcohol) + Base (Excess TEA or Pyridine) in MeCN.
  - Add the Nucleophile solution to the Sulfamoyl Chloride residue at 0°C.[1]
  - Stir at RT until completion.

## Critical Handling Parameters

Parameter	Recommendation	Rationale
Solvent Selection	DCM, MeCN, THF	Non-nucleophilic, polar enough to solubilize salts. Avoid alcohols or water.
Water Content	< 50 ppm	Stoichiometric hydrolysis is rapid. Use molecular sieves or freshly distilled solvents.
Temperature	Store at -20°C	Thermal decomposition can release and alkyl chlorides.
Atmosphere	Argon or	Prevents atmospheric moisture ingress.
Quenching	Dilute aq. HCl or NaHCO <sub>3</sub>	Only quench after the coupling step is complete.

## Quality Control & Troubleshooting

Since these intermediates are difficult to analyze by LCMS (due to hydrolysis on the column), <sup>1</sup>H NMR is the primary QC tool.

### NMR Signatures

- Alpha-Protons: The protons on the carbon adjacent to the nitrogen ( ) will show a distinct downfield shift compared to the starting amine.
  - Example: Dimethylamine ( ) ~2.3 ppm
  - Dimethylsulfamoyl chloride ~2.8–2.9 ppm.
- Purity Check: Look for the "Hydrolysis Hump." Sulfamic acids often appear as broad, shifting peaks or cause baseline distortion. Sharp, distinct multiplets usually indicate a clean chloride species.

### Common Failure Modes

- Problem: Low yield in coupling step.
  - Cause: Residual in the telescoped mixture reacted with the nucleophile.
  - Fix: Increase the duration/vacuum level of the "Purge" step (Protocol B, Step 2).
- Problem: Violent gas evolution upon adding amine.
  - Cause: Addition was too fast; exotherm caused release.
  - Fix: Slow down addition; improve cooling.<sup>[2]</sup>

### References

- Hydrolysis Kinetics: Ko, E. C. F., & Robertson, R. E. (1972). Hydrolysis of Sulfamoyl Chlorides. *Canadian Journal of Chemistry*, 50(7), 946–951. [Link](#)
- Synthesis Procedure: Behrend, R. (1881). Ueber die Einwirkung von Sulfurylchlorid auf Amine.[1][4] *Berichte der deutschen chemischen Gesellschaft*, 14, 722. (Foundational synthesis).
- Isocyanate Route: Burgess, E. M., Penton, H. R., & Taylor, E. A. (1973). Thermal reactions of alkyl N-carbomethoxysulfamate esters. *The Journal of Organic Chemistry*, 38(1), 26–31. [Link](#)
- Telescoping Strategies: Comparison of Sulfonamide Synthesis Methods. *Organic Chemistry Portal*. [Link](#)
- Safety Data: Sulfamoyl Chloride Safety Data Sheet. Sigma-Aldrich. [Link](#)

#### Need Custom Synthesis?

BenchChem offers custom synthesis for rare earth carbides and specific isotopic labeling.

Email: [info@benchchem.com](mailto:info@benchchem.com) or [Request Quote Online](#).

## Sources

- 1. [pdf.benchchem.com](https://pdf.benchchem.com) [[pdf.benchchem.com](https://pdf.benchchem.com)]
- 2. [Organic Syntheses Procedure](https://orgsyn.org) [[orgsyn.org](https://orgsyn.org)]
- 3. [spectrumchemical.com](https://spectrumchemical.com) [[spectrumchemical.com](https://spectrumchemical.com)]
- 4. [discovery.researcher.life](https://discovery.researcher.life) [[discovery.researcher.life](https://discovery.researcher.life)]
- To cite this document: BenchChem. [Application Note: Strategies for Handling Moisture-Sensitive Sulfamoyl Chloride Intermediates]. BenchChem, [2026]. [Online PDF]. Available at: [<https://www.benchchem.com/product/b1649445/docs#application-note-strategies-for-handling-moisture-sensitive-sulfamoyl-chloride-intermediates>]

---

#### Disclaimer & Data Validity:

The information provided in this document is for Research Use Only (RUO) and is strictly not intended for diagnostic or therapeutic procedures. While BenchChem strives to provide

accurate protocols, we make no warranties, express or implied, regarding the fitness of this product for every specific experimental setup.

**Technical Support:** The protocols provided are for reference purposes. Unsure if this reagent suits your experiment?

**Need Industrial/Bulk Grade?** [Request Custom Synthesis Quote](#)

## BenchChem

Our mission is to be the trusted global source of essential and advanced chemicals, empowering scientists and researchers to drive progress in science and industry.

### Contact

Address: 3281 E Guasti Rd

Ontario, CA 91761, United States

Phone: (601) 213-4426

Email: [info@benchchem.com](mailto:info@benchchem.com)

[Contact our Ph.D. Support Team for a compatibility check](#)