

Addressing limited clinical efficacy of AZD-5991

Author: BenchChem Technical Support Team. **Date:** December 2025

Compound of Interest

Compound Name: AZD-5991

Cat. No.: B1649328

[Get Quote](#)

Technical Support Center: AZD-5991

This technical support center provides troubleshooting guidance and frequently asked questions (FAQs) for researchers and drug development professionals working with the MCL-1 inhibitor, **AZD-5991**. The information provided is intended to help address challenges related to its clinical efficacy and to guide in-vitro and in-vivo experimental design.

Troubleshooting Guides

This section provides solutions to common problems encountered during experiments with **AZD-5991**.

Issue 1: Sub-optimal or Lack of Apoptotic Response in Cancer Cell Lines

Possible Cause 1: Intrinsic Resistance.

- Explanation: The target cells may not be primarily dependent on MCL-1 for survival. Cancer cells can rely on other anti-apoptotic proteins like BCL-2 or BCL-xL to evade apoptosis.[1][2]
- Troubleshooting Steps:
 - Assess BCL-2 Family Protein Expression: Perform Western blotting or proteomics to determine the relative expression levels of MCL-1, BCL-2, and BCL-xL in your cell line of interest. High levels of BCL-2 or BCL-xL may indicate a dependency on these proteins rather than MCL-1.

- Combination Therapy: Consider co-treatment of **AZD-5991** with a BCL-2 inhibitor (e.g., venetoclax).[1][3] This combination has shown synergistic effects in preclinical models of AML and MM.[3][4]

Possible Cause 2: Acquired Resistance.

- Explanation: Prolonged exposure to **AZD-5991** may lead to the upregulation of alternative survival pathways.
- Troubleshooting Steps:
 - Monitor Protein Expression Over Time: Analyze the expression of BCL-2 family proteins in your cell line after short-term and long-term exposure to **AZD-5991**.
 - Explore Downstream Signaling: Investigate signaling pathways that may be activated to compensate for MCL-1 inhibition.

Possible Cause 3: Experimental Conditions.

- Explanation: Sub-optimal drug concentration, incubation time, or cell health can affect the observed efficacy.
- Troubleshooting Steps:
 - Dose-Response and Time-Course Experiments: Conduct a matrix of experiments with varying concentrations of **AZD-5991** and different incubation times to determine the optimal conditions for your specific cell line.
 - Confirm Target Engagement: Use techniques like co-immunoprecipitation to confirm that **AZD-5991** is binding to MCL-1 in your experimental system.

Issue 2: Inconsistent Results in Animal Models

Possible Cause 1: Pharmacokinetic/Pharmacodynamic (PK/PD) Issues.

- Explanation: Inadequate drug exposure at the tumor site can lead to a lack of efficacy. **AZD-5991** is administered intravenously.[4]

- Troubleshooting Steps:
 - PK/PD Modeling: If possible, perform pharmacokinetic studies to measure the concentration of **AZD-5991** in plasma and tumor tissue over time. Correlate drug levels with pharmacodynamic markers of apoptosis (e.g., cleaved caspase-3) in the tumor.
 - Optimize Dosing Regimen: Based on PK/PD data, adjust the dose and schedule of **AZD-5991** administration.

Possible Cause 2: Tumor Microenvironment-Mediated Resistance.

- Explanation: The bone marrow microenvironment can protect cancer cells from apoptosis induced by MCL-1 inhibition.[1] Soluble factors and direct cell-cell contact can promote survival.[1]
- Troubleshooting Steps:
 - Co-culture Experiments: In vitro, co-culture your cancer cells with bone marrow stromal cells to mimic the microenvironment and assess the efficacy of **AZD-5991** under these conditions.
 - Combination with Stroma-Targeting Agents: Consider combining **AZD-5991** with drugs that disrupt the protective effects of the tumor microenvironment.

Frequently Asked Questions (FAQs)

Q1: What is the mechanism of action of **AZD-5991**?

A1: **AZD-5991** is a potent and selective small-molecule inhibitor of the anti-apoptotic protein Myeloid Cell Leukemia 1 (MCL-1).[4][5] It mimics the action of BH3-only proteins, binding to the BH3-binding groove of MCL-1.[3] This prevents MCL-1 from sequestering pro-apoptotic proteins like BAK and BAX, thereby unleashing the mitochondrial pathway of apoptosis, leading to cancer cell death.[6][7]

Q2: Why was the clinical development of **AZD-5991** halted?

A2: The Phase 1 clinical trial for **AZD-5991** in patients with relapsed/refractory hematologic malignancies was terminated early due to a combination of limited clinical activity and safety

concerns.[8][9][10] While some objective responses were observed in patients with myelodysplastic syndromes (MDS)[8][11], the overall response rate was low.[3][11] A significant safety issue was the high incidence of asymptomatic elevations in troponin levels, a biomarker for cardiac injury, raising concerns about potential cardiotoxicity.[3][8][12]

Q3: What are the known mechanisms of resistance to **AZD-5991**?

A3: Resistance to **AZD-5991** can be multifactorial:

- Upregulation of other anti-apoptotic proteins: Cancer cells can compensate for MCL-1 inhibition by upregulating other BCL-2 family members, particularly BCL-2.[1][2]
- Tumor microenvironment: The bone marrow microenvironment can secrete pro-survival cytokines and growth factors that protect cancer cells from **AZD-5991**-induced apoptosis.[1]
- Activation of survival signaling pathways: Downstream signaling pathways, such as the ERK pathway, can be activated to promote survival and counteract the effects of MCL-1 inhibition. [13]

Q4: What are the preclinical indications of **AZD-5991**'s efficacy?

A4: Preclinical studies demonstrated promising activity of **AZD-5991**, particularly in hematological malignancies. It showed potent single-agent activity in multiple myeloma (MM) and acute myeloid leukemia (AML) cell lines and in vivo models.[4][6][14] Furthermore, **AZD-5991** exhibited synergistic anti-tumor effects when combined with the BCL-2 inhibitor venetoclax in models of AML and MM, and with the proteasome inhibitor bortezomib in MM models.[3][4]

Data and Protocols

Quantitative Data Summary

Table 1: In Vitro Activity of **AZD-5991** in Hematological Cancer Cell Lines

| Cell Line | Cancer Type | Caspase EC50 (nM) |
|-----------|------------------------|-------------------|
| MOLP-8 | Multiple Myeloma | 33 |
| MV4;11 | Acute Myeloid Leukemia | 24 |
| H929 | Multiple Myeloma | 64 |
| MM.1S | Multiple Myeloma | 417 |

Data extracted from preclinical studies.[1][4] EC50 values represent the concentration of **AZD-5991** required to induce 50% of the maximal caspase activity.

Table 2: Clinical Trial (NCT03218683) Adverse Events ($\geq 30\%$ of patients)

| Adverse Event | Percentage of Patients |
|---------------|------------------------|
| Diarrhea | 59.0% |
| Nausea | 55.1% |
| Vomiting | 47.4% |

Data from the Phase 1 first-in-human study of **AZD-5991**. [3][11]

Experimental Protocols

Protocol 1: Assessment of Apoptosis by Annexin V/Propidium Iodide (PI) Staining

- Cell Seeding: Seed cancer cells in a 6-well plate at a density of 2×10^5 cells/well and allow them to adhere overnight.
- Treatment: Treat cells with varying concentrations of **AZD-5991** (e.g., 1 nM to 10 μ M) or vehicle control (DMSO) for 24, 48, and 72 hours.
- Cell Harvesting: Harvest both adherent and floating cells by trypsinization and centrifugation.
- Staining: Resuspend the cell pellet in 1X Annexin V binding buffer. Add Annexin V-FITC and Propidium Iodide (PI) and incubate in the dark for 15 minutes at room temperature.

- Flow Cytometry: Analyze the stained cells using a flow cytometer. Annexin V-positive/PI-negative cells are considered early apoptotic, while Annexin V-positive/PI-positive cells are late apoptotic or necrotic.

Protocol 2: Western Blot Analysis of BCL-2 Family Proteins

- Cell Lysis: After treatment with **AZD-5991**, wash cells with ice-cold PBS and lyse them in RIPA buffer supplemented with protease and phosphatase inhibitors.
- Protein Quantification: Determine the protein concentration of the lysates using a BCA protein assay.
- SDS-PAGE and Transfer: Separate equal amounts of protein on an SDS-polyacrylamide gel and transfer them to a PVDF membrane.
- Immunoblotting: Block the membrane with 5% non-fat milk or BSA in TBST for 1 hour. Incubate with primary antibodies against MCL-1, BCL-2, BCL-xL, and a loading control (e.g., GAPDH or β -actin) overnight at 4°C.
- Detection: Wash the membrane and incubate with HRP-conjugated secondary antibodies. Detect the protein bands using an enhanced chemiluminescence (ECL) substrate and an imaging system.

Visualizations

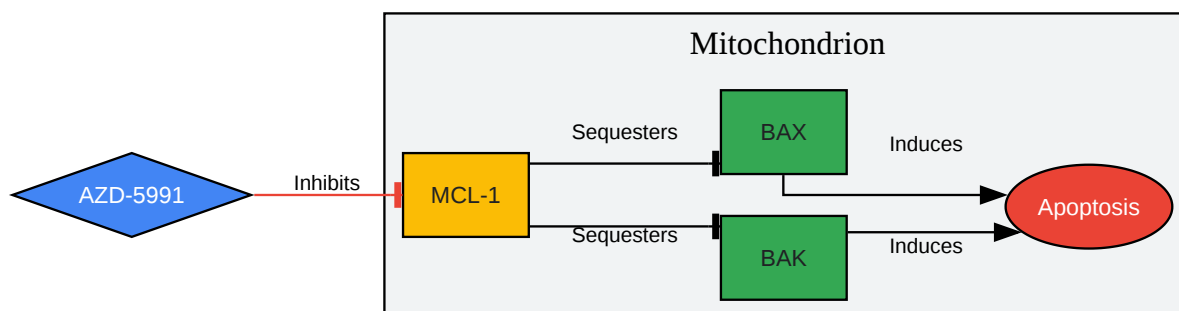

[Click to download full resolution via product page](#)

Caption: Mechanism of action of **AZD-5991**.

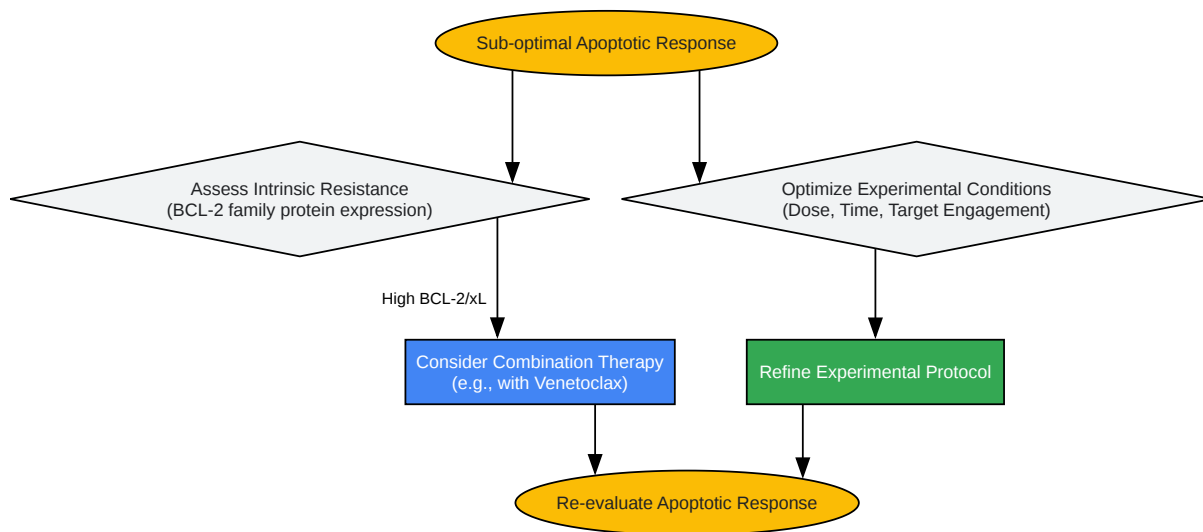

[Click to download full resolution via product page](#)

Caption: Troubleshooting workflow for sub-optimal response.

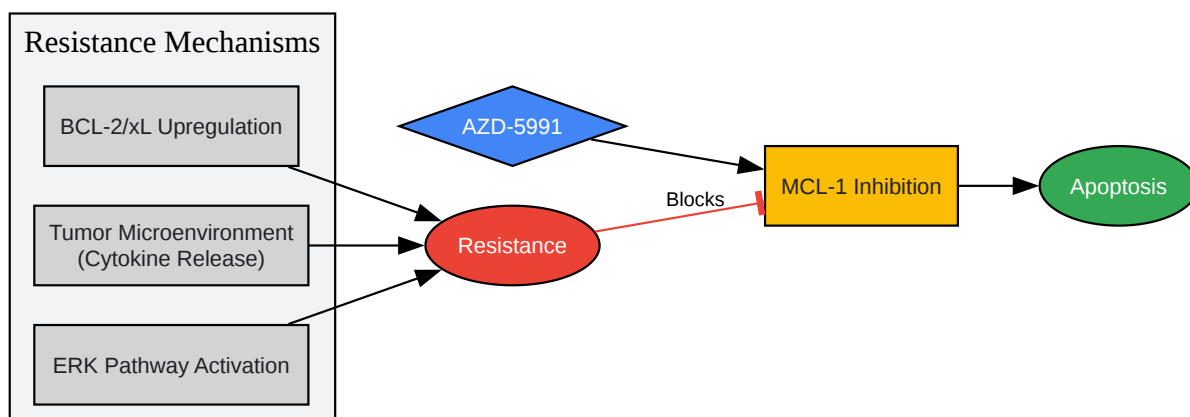

[Click to download full resolution via product page](#)

Caption: Overview of resistance pathways to **AZD-5991**.

Need Custom Synthesis?

BenchChem offers custom synthesis for rare earth carbides and specific isotopic labeling.

Email: info@benchchem.com or [Request Quote Online](#).

References

- 1. ashpublications.org [ashpublications.org]
- 2. biorxiv.org [biorxiv.org]
- 3. aacrjournals.org [aacrjournals.org]
- 4. AZD5991 [openinnovation.astrazeneca.com]
- 5. Facebook [cancer.gov]
- 6. selleckchem.com [selleckchem.com]
- 7. MCL-1 inhibition in cancer treatment - PMC [pmc.ncbi.nlm.nih.gov]
- 8. aacrjournals.org [aacrjournals.org]
- 9. Results of Phase I study of MCL-1 inhibition with AZD5991 in R/R hematologic malignancies | VJHemOnc [vjhemonc.com]
- 10. A Phase 1 First-in-Human Study of the MCL-1 Inhibitor AZD5991 in Patients with Relapsed/Refractory Hematologic Malignancies - PMC [pmc.ncbi.nlm.nih.gov]
- 11. aacrjournals.org [aacrjournals.org]
- 12. youtube.com [youtube.com]
- 13. probiologists.com [probiologists.com]
- 14. medchemexpress.com [medchemexpress.com]
- To cite this document: BenchChem. [Addressing limited clinical efficacy of AZD-5991]. BenchChem, [2025]. [Online PDF]. Available at: [<https://www.benchchem.com/product/b1649328#addressing-limited-clinical-efficacy-of-azd-5991>]

Disclaimer & Data Validity:

The information provided in this document is for Research Use Only (RUO) and is strictly not intended for diagnostic or therapeutic procedures. While BenchChem strives to provide

accurate protocols, we make no warranties, express or implied, regarding the fitness of this product for every specific experimental setup.

Technical Support: The protocols provided are for reference purposes. Unsure if this reagent suits your experiment? [[Contact our Ph.D. Support Team for a compatibility check](#)]

Need Industrial/Bulk Grade? [Request Custom Synthesis Quote](#)

BenchChem

Our mission is to be the trusted global source of essential and advanced chemicals, empowering scientists and researchers to drive progress in science and industry.

Contact

Address: 3281 E Guasti Rd

Ontario, CA 91761, United States

Phone: (601) 213-4426

Email: info@benchchem.com