

Technical Support Center: Managing Reaction Exotherms in Large-Scale Pyridine Fluorination

Author: BenchChem Technical Support Team. **Date:** April 2026

Compound of Interest

Compound Name: *3-Benzyloxy-5-(trifluoromethyl)pyridine*

Cat. No.: *B1646071*

[Get Quote](#)

Welcome to the Technical Support Center for large-scale pyridine fluorination. This guide is designed for researchers, scientists, and drug development professionals to provide in-depth technical guidance on managing the significant reaction exotherms associated with these processes. Our focus is on providing practical, field-proven insights to ensure both the safety and success of your large-scale fluorination campaigns.

Frequently Asked Questions (FAQs)

Q1: Which pyridine fluorination methods are most prone to dangerous exotherms at scale?

A1: Several common methods for synthesizing fluorinated pyridines carry a significant risk of exothermic events, particularly at a large scale. These include:

- Nucleophilic Aromatic Substitution (S_NAr): S_NAr reactions, especially with highly activated pyridine rings (e.g., those with strong electron-withdrawing groups), can be highly exothermic.[1] The reaction rate and the resulting heat generation are sensitive to the choice of solvent, temperature, and the specific nature of the leaving group and activating groups.[1]

- **Balz-Schiemann Reaction:** The thermal decomposition of the intermediate diazonium salt in the Balz-Schiemann reaction is notoriously exothermic and can be challenging to control, sometimes leading to runaway reactions.[1][2] The accumulation of potentially explosive diazonium salts is a major safety hazard at scale.[2]
- **Direct C-H Fluorination:** While a powerful modern technique, direct C-H fluorination often employs highly reactive and energetic fluorinating agents.[1] For instance, reactions with reagents like silver(II) fluoride (AgF_2) can be exothermic if not properly controlled.[1][3]

Q2: What are the primary safety hazards associated with uncontrolled exotherms in pyridine fluorination?

A2: The primary hazards stem from the rapid and uncontrolled release of energy, which can lead to:

- **Thermal Runaway:** A thermal runaway occurs when the heat generated by the reaction exceeds the rate of heat removal, leading to an accelerating increase in temperature and pressure.[1][4][5] This can result in reactor over-pressurization, vessel rupture, and the release of toxic and flammable materials.
- **Decomposition of Reagents and Products:** Elevated temperatures can cause the decomposition of thermally sensitive materials, such as diazonium salts in the Balz-Schiemann reaction, which can be explosive.[2]
- **Release of Toxic and Corrosive Gases:** Many fluorinating agents and byproducts are hazardous. For example, moisture sensitivity can lead to the formation of hydrogen fluoride (HF), which is extremely corrosive and toxic.[1][6]
- **Solvent Fires:** If the reaction temperature exceeds the boiling point of the solvent, it can lead to a rapid increase in pressure and the potential for a flammable vapor cloud.[1]

Q3: How can I effectively control the temperature of a large-scale pyridine fluorination reaction?

A3: Effective temperature control is paramount for safety and success. Key strategies include:

- **Slow and Controlled Reagent Addition:** Adding the limiting reagent slowly is a fundamental technique to manage the rate of heat generation.[\[1\]\[7\]](#)
- **Efficient Cooling:** Utilize a robust cooling system, such as a recirculating chiller, and ensure good heat transfer through efficient stirring and appropriate reactor design.[\[1\]\[7\]\[8\]](#)
- **Reaction Dilution:** Performing the reaction in a larger volume of a suitable solvent can help dissipate the heat generated.[\[1\]](#)
- **Real-time Monitoring:** Continuously monitor the internal reaction temperature with a calibrated probe.[\[1\]\[7\]](#)
- **Flow Chemistry:** For highly exothermic reactions, transitioning to a continuous flow setup offers superior heat transfer and temperature control, significantly enhancing safety.[\[1\]\[9\]\[10\]](#)

Q4: What is flow chemistry, and how does it mitigate the risks of exothermic reactions?

A4: Flow chemistry involves performing chemical reactions in a continuously flowing stream through a reactor, rather than in a traditional batch vessel.[\[1\]](#) This approach offers significant advantages for managing exotherms:

- **Superior Heat Transfer:** Flow reactors have a much higher surface-area-to-volume ratio compared to batch reactors, allowing for extremely efficient heat dissipation and preventing the formation of hot spots.[\[1\]\[10\]\[11\]](#)
- **Precise Temperature Control:** The small reaction volume at any given time allows for rapid and precise temperature adjustments.[\[1\]\[11\]](#)
- **Minimized Reaction Volume:** The small amount of material reacting at any instant minimizes the potential hazard of an uncontrolled exotherm.[\[1\]](#)
- **Enhanced Safety:** The enclosed nature of flow systems can reduce operator exposure to hazardous materials.[\[1\]\[12\]](#)

Troubleshooting Guides

Issue 1: Uncontrolled Temperature Excursion During Batch Fluorination

Scenario: You are performing a large-scale Halogen Exchange (Halex) reaction. During the addition of the fluoride source, you observe a rapid and unexpected increase in the internal reaction temperature that the cooling system cannot control.

Immediate Action Plan:

- **Stop Reagent Addition Immediately:** Cease the addition of all reagents to prevent further heat generation.[\[13\]](#)
- **Maximize Cooling:** Ensure your cooling system is operating at maximum capacity.[\[13\]](#) If using a cooling bath, add more of the cooling agent (e.g., dry ice).[\[13\]](#)
- **Prepare for Emergency Quenching:** Have a pre-determined and validated quenching agent ready to be added to the reactor to rapidly halt the reaction.[\[13\]](#) The choice of quenching agent should be part of your initial risk assessment.[\[13\]](#)
- **Alert Personnel and Evacuate if Necessary:** Inform colleagues of the situation. If the temperature continues to rise uncontrollably, evacuate the area immediately.[\[13\]](#)
- **Document the Event:** Once the situation is under control, thoroughly document the details of the excursion, including the maximum temperature reached and the duration. This information is crucial for investigating the cause and preventing recurrence.[\[13\]](#)

Root Cause Analysis and Corrective Actions:

Possible Cause	Troubleshooting Step	Expected Outcome
Reagent Addition Rate Too Fast	Reduce the addition rate of the limiting reagent. Consider using a syringe pump for precise control.	Slower, more controlled heat release, allowing the cooling system to keep pace.
Inadequate Cooling Capacity	Before scaling up, perform calorimetric studies to determine the heat of reaction and ensure your cooling system can handle the heat load.	Accurate sizing of cooling equipment to prevent temperature overshoots.
Poor Heat Transfer	Increase the stirring rate to improve mixing and heat dissipation. Ensure the reactor is appropriately sized and designed for efficient heat transfer.	Elimination of hot spots and more uniform temperature distribution.
Incorrect Reaction Concentration	Perform the reaction at a higher dilution to increase the thermal mass of the system.	The solvent will absorb more of the heat generated, moderating the temperature rise.

Issue 2: Localized Hotspots and Byproduct Formation in a Continuous Flow Reactor

Scenario: You are using a continuous flow reactor for a direct C-H fluorination. While the overall reaction temperature appears stable, you observe inconsistent product quality and the formation of degradation byproducts, suggesting localized overheating.

Troubleshooting Steps:

- **Improve Mixing:** Ensure the micromixer or T-junction is functioning correctly to achieve rapid and efficient mixing of the reagent streams before they enter the heated reaction zone.

- **Optimize Flow Rates:** Adjust the flow rates of the reagent streams. Higher flow rates can sometimes improve heat transfer, but may reduce residence time. A careful optimization is required.
- **Reactor Material and Design:** Consider the thermal conductivity of the reactor material. Metallic reactors (e.g., stainless steel, Hastelloy) offer better heat transfer than glass or PFA. The geometry of the reactor channels also plays a crucial role.
- **Distributed Reagent Addition:** For highly exothermic reactions, consider a reactor design that allows for the distributed addition of one of the reagents along the length of the reactor. This can help to spread out the heat generation.

Experimental Protocols

Protocol 1: Reaction Calorimetry for Safe Scale-Up

Objective: To determine the heat of reaction (ΔH_{rxn}) and the maximum temperature of the synthetic reaction (MTSR) to ensure safe scale-up.

Methodology:

- **Setup:** Utilize a reaction calorimeter (e.g., RC1e) equipped with a temperature probe, a calibration heater, and a controlled reagent addition system.
- **Calibration:** Perform a calibration of the calorimeter to determine the overall heat transfer coefficient (U) and the heat capacity of the system (Cp).
- **Reaction Run:**
 - Charge the reactor with the pyridine substrate and solvent.
 - Establish a stable initial temperature.
 - Add the fluorinating agent at a controlled rate, mimicking the planned large-scale addition profile.
 - Continuously monitor the internal temperature and the jacket temperature.

- Data Analysis:
 - Calculate the heat flow (q) from the reaction using the equation: $q = UA(T_j - T_r) + mC_p(dT_r/dt)$.
 - Integrate the heat flow over time to determine the total heat of reaction.
 - Use the heat of reaction and the heat capacity of the system to calculate the adiabatic temperature rise and the MTSR.

Data Presentation:

Parameter	Symbol	Value	Units
Heat of Reaction	ΔH_{rxn}	-150	kJ/mol
Overall Heat Transfer Coefficient	U	350	W/(m ² ·K)
Heat Capacity of Reaction Mass	$C_{p,rxn}$	1.8	kJ/(kg·K)
Adiabatic Temperature Rise	ΔT_{ad}	85	°C
Maximum Temperature of Synthetic Reaction	MTSR	125	°C

Protocol 2: Emergency Quenching Procedure Validation

Objective: To validate the effectiveness of a chosen quenching agent and procedure on a small scale before implementation at large scale.

Methodology:

- Selection of Quenching Agent: Choose a quenching agent that will rapidly and irreversibly stop the fluorination reaction without generating excessive heat or hazardous byproducts.

[14] Common quenching agents include water, aqueous sodium bicarbonate, or a suitable reducing agent.

- Small-Scale Test:
 - In a fume hood, run the fluorination reaction at the intended concentration and temperature in a small reaction vessel.
 - At the point of maximum reactivity (determined by reaction monitoring), rapidly add the chosen quenching agent.
 - Carefully observe and record any temperature increase, gas evolution, or other changes. [15]
- Analysis: Analyze the quenched reaction mixture by a suitable method (e.g., NMR, LC-MS) to confirm that the reaction has been completely stopped and that no new hazardous species have been formed.
- Scale-Up Considerations: Based on the small-scale results, determine the appropriate volume and addition rate of the quenching agent for the large-scale process. Ensure the large-scale reactor has sufficient headspace to accommodate the volume of the quench solution.[14]

Visualizations

Decision Tree for Managing Temperature Excursions

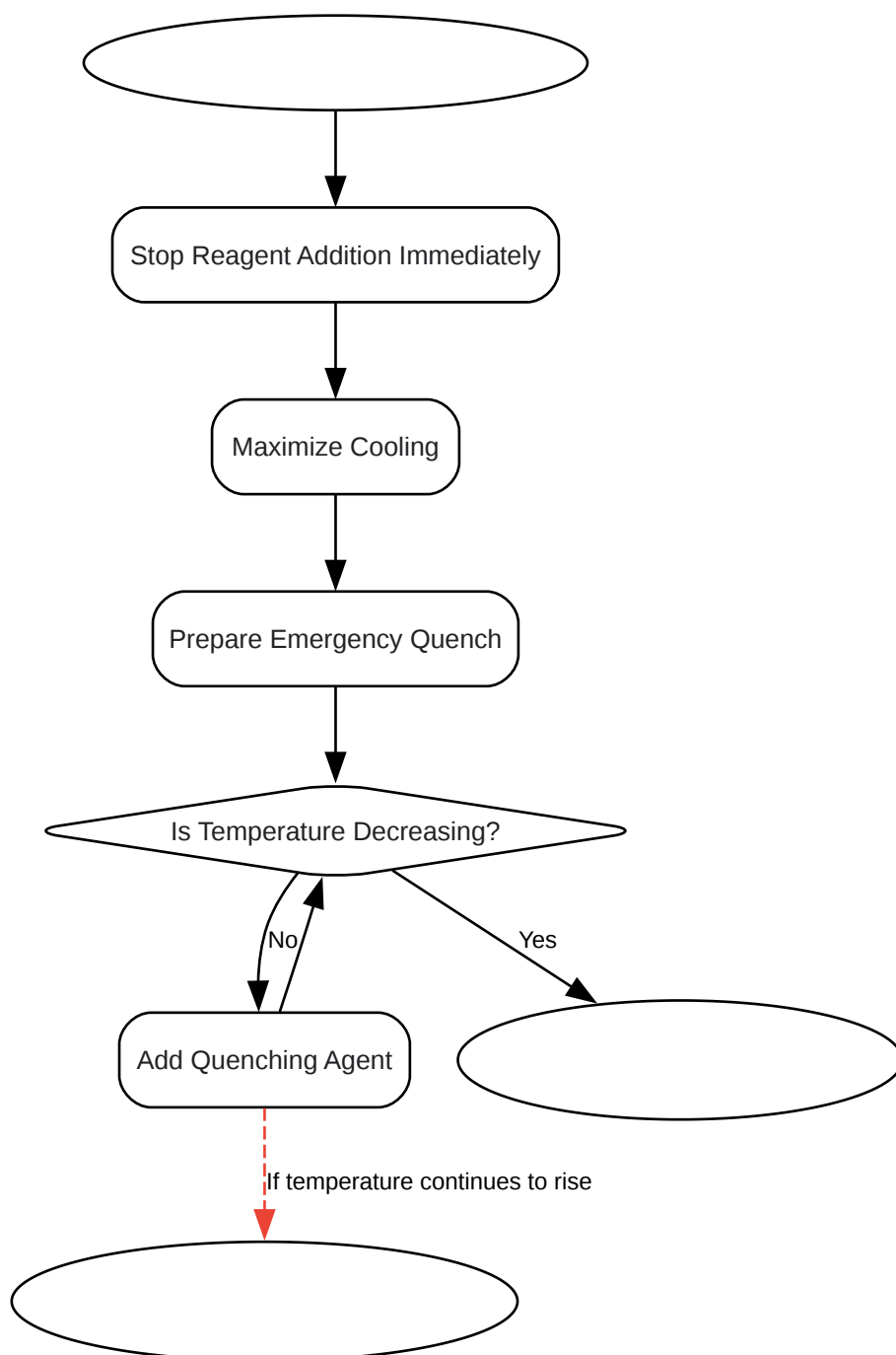

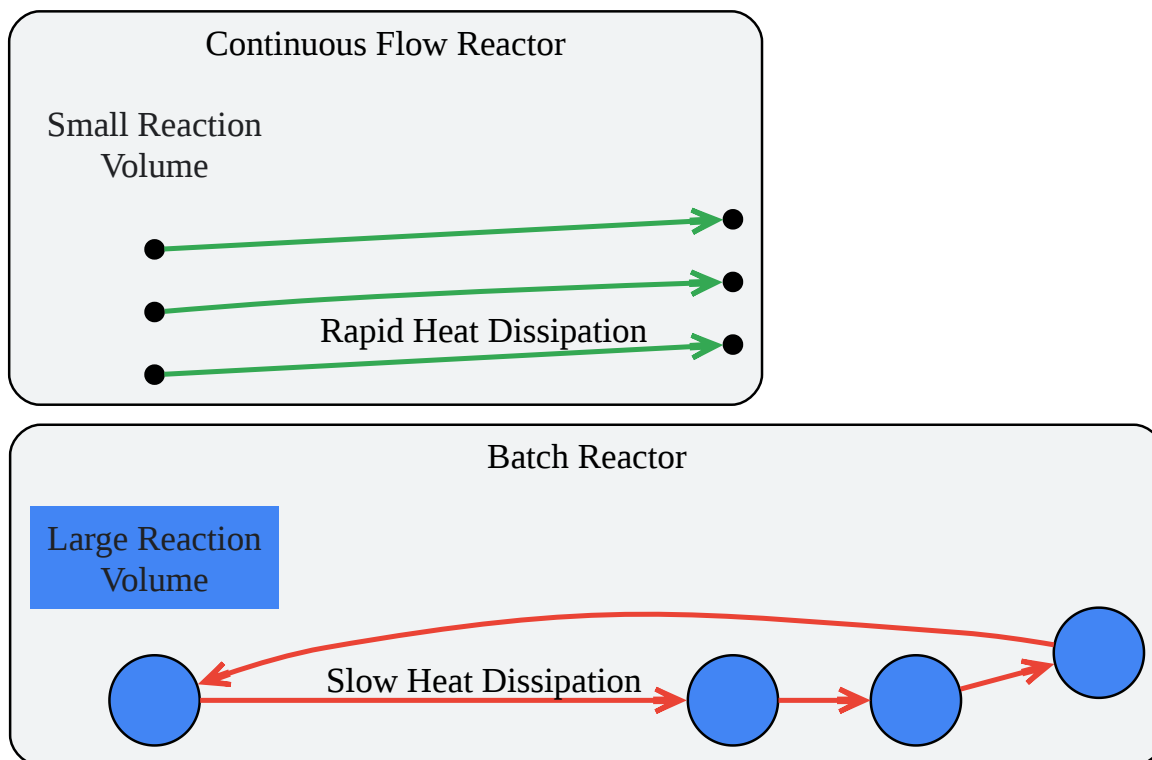

[Click to download full resolution via product page](#)

Caption: Comparison of heat dissipation in batch versus continuous flow reactors.

References

- Technical Support Center: Scalable Synthesis of Fluorinated Pyridines - Benchchem. (n.d.).
- Managing exothermic reactions in fluoropyridine synthesis - Benchchem. (n.d.).
- Mielke, E., Plouffe, P., Koushik, N., Eyholzer, M., Gottsponer, M., Kockmann, N., Macchi, A., & Roberge, D. M. (2017). Local and overall heat transfer of exothermic reactions in microreactor systems. *Reaction Chemistry & Engineering*, 2(5), 763–775. [[Link](#)]
- Quench Systems - HSE. (2025, August 19).
- Lesson 6: Exothermic Tank Reactor. (2006).
- Lecture 12 Heat Exchange in Reactors and Its Effect on Reaction Processes - Farabi University. (n.d.).
- Practical Guidelines for the Safe Use of Fluorine Gas Employing Continuous Flow Technology | Request PDF. (n.d.). Retrieved March 11, 2026, from [[Link](#)]

- Safer fluorination process developed using flow electrochemistry. (2021, August 2). Chemistry World. Retrieved from [\[Link\]](#)
- Fier, P. S., & Hartwig, J. F. (2013). Selective C-H fluorination of pyridines and diazines inspired by a classic amination reaction. *Science*, 342(6161), 956–960. [\[Link\]](#)
- Fluorine Safety. (n.d.).
- Integration of Heat Transfer and Chemical Reactions. (2005, February 25). Wiley-VCH. Retrieved from [\[Link\]](#)
- Troubleshooting guide for the fluorination of pyridinyl ethanone - Benchchem. (n.d.).
- Quench. (n.d.).
- Flow electrochemistry: a safe tool for fluorine chemistry. (2021, June 4). *Chemical Science*. [\[Link\]](#)
- Cherkasov, N. (2021, September 24). How to calculate heat transfer in continuous flow applications. *Stoli Chem*. Retrieved from [\[Link\]](#)
- Application Notes and Protocols for Handling Gaseous Fluorinating Agents - Benchchem. (n.d.).
- Best Practices for Working with Chemical Reactions in the Lab. (2025, December 25).
- Safe scale-up with exothermic reactions. (n.d.). *Process Technology Online*. Retrieved from [\[Link\]](#)
- ChemInform Abstract: Selective C-H Fluorination of Pyridines and Diazines Inspired by a Classic Amination Reaction. | Request PDF. (n.d.). Retrieved March 11, 2026, from [\[Link\]](#)
- Selective fluorination of pyridine, quinoline and quinoxaline derivatives with fluorine–iodine mixtures. (n.d.). *Journal of the Chemical Society, Perkin Transactions 1*. [\[Link\]](#)
- Technical Support Center: Managing Exothermic Reactions in Energetic Material Synthesis - Benchchem. (n.d.).
- Perfluoropyridine: Discovery, Chemistry, and Applications in Polymers and Material Science. (2022, February 28). *Polymers*. [\[Link\]](#)

- Benefits of Continuous Flow Chemistry. (n.d.). Mettler Toledo. Retrieved from [\[Link\]](#)
- Continuous-Flow Chemistry. (2017, April 4). Wiley Analytical Science. Retrieved from [\[Link\]](#)
- Fluorination Chemistry Performed in a Modular Flow Reactor Introduction to Flow Chemistry. (n.d.). Vapourtec. Retrieved from [\[Link\]](#)
- Fier, P. S., & Hartwig, J. F. (2017). Site-Selective C-H Fluorination of Pyridines and Diazines with AgF₂. *Organic Syntheses*, 94, 284–299. [\[Link\]](#)
- McCullough, J. P., Douslin, D. R., Messerly, J. F., Hossenlopp, I. A., Kincheloe, T. C., & Waddington, G. (1957). Pyridine: Experimental and Calculated Chemical Thermodynamic Properties between 0 and 1500°K.; a Revised Vibrational Assignment. *Journal of the American Chemical Society*, 79(16), 4289–4295. [\[Link\]](#)
- A Modular Approach to meta-Fluorinated Pyridines. (n.d.). ChemRxiv. [\[Link\]](#)
- Late-Stage Fluorination: From Fundamentals to Application. (n.d.). PMC. Retrieved from [\[Link\]](#)
- Technical Support Center: Scaling Up Fluorination Reactions with 1-Fluoro-1H-imidazole - Benchchem. (n.d.).
- C3 Selective chalcogenation and fluorination of pyridine using classic Zincke imine intermediates. (2024, August 28). PMC. Retrieved from [\[Link\]](#)
- C–H fluorination promoted by pyridine N-oxyl radicals. (n.d.). Green Chemistry. [\[Link\]](#)
- Investigations of the Thermal Runaway Process of a Fluorine-Free Electrolyte Li-Ion Battery Cell. (2021, July 2). Diva-Portal.org. Retrieved from [\[Link\]](#)
- Thermal Runaway of Lithium-Ion Batteries Employing Flame-Retardant Fluorinated Electrolytes. (2021, December 29). ResearchGate. Retrieved from [\[Link\]](#)

Need Custom Synthesis?

BenchChem offers custom synthesis for rare earth carbides and specific isotopic labeling.

Email: info@benchchem.com or [Request Quote Online](#).

Sources

- [1. pdf.benchchem.com \[pdf.benchchem.com\]](https://pdf.benchchem.com)
- [2. pdf.benchchem.com \[pdf.benchchem.com\]](https://pdf.benchchem.com)
- [3. orgsyn.org \[orgsyn.org\]](https://orgsyn.org)
- [4. diva-portal.org \[diva-portal.org\]](https://diva-portal.org)
- [5. researchgate.net \[researchgate.net\]](https://researchgate.net)
- [6. pdf.benchchem.com \[pdf.benchchem.com\]](https://pdf.benchchem.com)
- [7. labproinc.com \[labproinc.com\]](https://labproinc.com)
- [8. farabi.university \[farabi.university\]](https://farabi.university)
- [9. researchgate.net \[researchgate.net\]](https://researchgate.net)
- [10. analyticalscience.wiley.com \[analyticalscience.wiley.com\]](https://analyticalscience.wiley.com)
- [11. How to calculate heat transfer in continuous flow applications — Stoli Chem \[stolichem.com\]](https://stolichem.com)
- [12. chemistryworld.com \[chemistryworld.com\]](https://chemistryworld.com)
- [13. pdf.benchchem.com \[pdf.benchchem.com\]](https://pdf.benchchem.com)
- [14. hse.gov.uk \[hse.gov.uk\]](https://hse.gov.uk)
- [15. chem.rochester.edu \[chem.rochester.edu\]](https://chem.rochester.edu)
- To cite this document: BenchChem. [Technical Support Center: Managing Reaction Exotherms in Large-Scale Pyridine Fluorination]. BenchChem, [2026]. [Online PDF]. Available at: [<https://www.benchchem.com/product/b1646071/docs#technical-support-center-managing-reaction-exotherms-in-large-scale-pyridine-fluorination>]

Disclaimer & Data Validity:

The information provided in this document is for Research Use Only (RUO) and is strictly not intended for diagnostic or therapeutic procedures. While BenchChem strives to provide accurate protocols, we make no warranties, express or implied, regarding the fitness of this product for every specific experimental setup.

Technical Support: The protocols provided are for reference purposes. Unsure if this reagent suits your experiment?

Need Industrial/Bulk Grade? [Request Custom Synthesis Quote](#)

BenchChem

Our mission is to be the trusted global source of essential and advanced chemicals, empowering scientists and researchers to drive progress in science and industry.

Contact

Address: 3281 E Guasti Rd
Ontario, CA 91761, United States
Phone: (601) 213-4426
Email: info@benchchem.com

[Contact our Ph.D. Support Team for a compatibility check](#)