

Technical Reference Guide: N-(4-Methoxy-2-methyl-5-nitrophenyl)acetamide Standards

Author: BenchChem Technical Support Team. **Date:** May 2026

Compound of Interest

Compound Name: *N-(4-Methoxy-2-methyl-5-nitrophenyl)acetamide*

CAS No.: 196194-97-5

Cat. No.: B1646823

[Get Quote](#)

Executive Summary & Chemical Profile

N-(4-Methoxy-2-methyl-5-nitrophenyl)acetamide (CAS: 196194-97-5) is a critical reference material used primarily in two high-stakes domains: as a genotoxic impurity marker in the synthesis of acetanilide-based pharmaceuticals and as a biomarker for oxidative stress (specifically peroxynitrite-mediated oxidation of 2-methylmethacetin).

Accurate quantification of this compound is essential due to the nitro-aromatic moiety, which often flags a compound for mutagenicity alerts (ICH M7 guidelines).[1] This guide compares sourcing options, details validation protocols, and provides the specific synthesis pathway to distinguish it from its structural analogs.

Chemical Identity Card

Property	Specification
CAS Number	196194-97-5 (Distinct from the non-methylated analog 119-81-3)
IUPAC Name	N-(4-Methoxy-2-methyl-5-nitrophenyl)acetamide
Molecular Formula	C ₁₀ H ₁₂ N ₂ O ₄
Molecular Weight	224.21 g/mol
Appearance	Colorless to pale yellow laths (crystallized from water)
Solubility	DMSO, Methanol, warm Water; sparingly soluble in cold water
Key Structural Feature	Nitro group at C5 twisted ~12° out of phenyl plane; Acetamide twisted ~47°

Comparative Analysis: Reference Standard Grades

When sourcing this material for analytical method validation (HPLC or LC-MS), researchers often face a choice between three "grades" of material. The following analysis objectively compares these alternatives based on regulatory suitability and experimental risk.

Decision Matrix: Selecting the Right Standard

Feature	Option A: ISO 17034 CRM	Option B: Analytical Standard (>98%)	Option C: Research/Synthesis Grade (~95%)
Definition	Certified Reference Material with metrological traceability.	High-purity material characterized by HPLC/NMR.[1]	Material intended as a synthesis intermediate.[1][2]
Traceability	High (NIST/BIPM traceable weights used).[1]	Medium (CoA provided, but uncertainty not calculated).[1]	Low (Batch-to-batch variability high).[1]
Primary Use	Release testing of GMP drug substances; Legal disputes.[1]	Method development; Routine impurity quantification; R&D.	Synthesis starting material; Qualitative identification (RT check).[1]
Cost Factor	(Often custom synthesis required).[1]	(Standard commercial pricing).[1]	\$ (Bulk availability).[1]
Risk Profile	Lowest Risk.	Acceptable Risk (If secondary verification is performed).	High Risk (Likely contains regioisomers like the 6-nitro analog).[1]

Expert Insight: For **N-(4-Methoxy-2-methyl-5-nitrophenyl)acetamide**, Option B (Analytical Standard) is the industry standard. True CRMs (Option A) are rarely available off-the-shelf for this specific metabolite.[1] Researchers must often purchase Option B and perform an in-house "Standard Qualification" (described in Section 4).[1]

Critical Sourcing Warning

Do not confuse CAS 196194-97-5 with CAS 119-81-3.

- CAS 119-81-3:N-(4-Methoxy-2-nitrophenyl)acetamide (Lacks the 2-methyl group).[2][3]

- Impact: Using the wrong standard will result in a retention time shift (approx.[1] 0.5 - 1.5 min difference in reverse-phase C18) and incorrect mass transitions (210 vs 224 Da), leading to false negatives in impurity screening.[1]

Technical Workflow: Synthesis & Metabolic Origin

Understanding the origin of this impurity ensures robust method development.[1] It is formed via electrophilic nitration where the methoxy group directs the nitro group to the ortho position (C5), while the acetamide group weakly deactivates the ring.[1][4][5]

Pathway Diagram

The following diagram illustrates the formation pathway (biomimetic and synthetic) and the critical divergence from potential regioisomers.

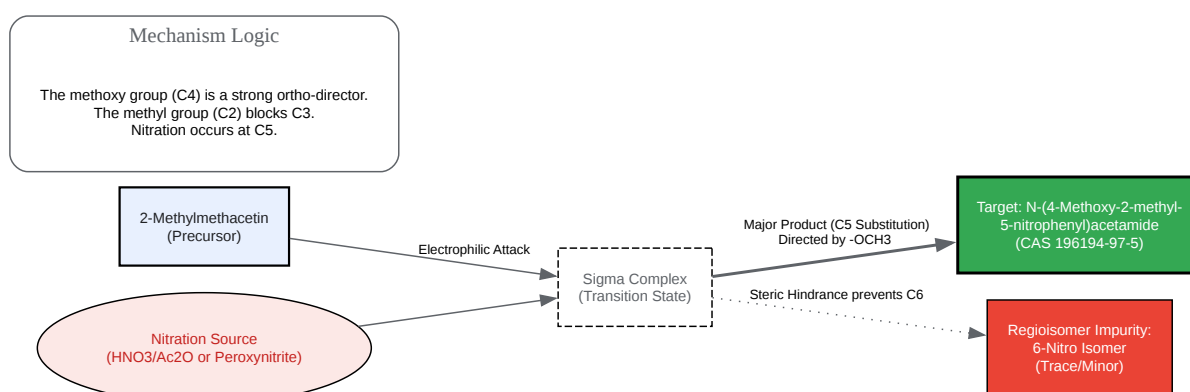

[Click to download full resolution via product page](#)

Figure 1: Reaction pathway showing the regioselective formation of the target standard.[1][4][6][7] The 5-nitro position is favored over the 6-nitro position due to steric hindrance from the acetamide group.[1]

Experimental Protocol: Standard Qualification

If a Certified Reference Material is unavailable, you must qualify your Analytical Standard (Option B) before using it for quantitative work.[1]

Protocol: "Self-Validating" Purity Check via HPLC-PDA-MS

Objective: Confirm identity and purity using orthogonal detection (UV and Mass Spec).

Reagents:

- Acetonitrile (LC-MS Grade)[1]
- Water (Milli-Q, 18.2 MΩ)[1]
- Formic Acid (0.1%)[1]
- Column: C18 Reverse Phase (e.g., Agilent Zorbax Eclipse Plus, 100mm x 2.1mm, 1.8μm)[1]

Instrument Parameters:

- Flow Rate: 0.3 mL/min[1]
- Column Temp: 40°C
- Detection A (UV): PDA scanning 210–400 nm (Extract chromatogram at 254 nm and 280 nm).[1]
- Detection B (MS): ESI Positive Mode.

Gradient Profile:

Time (min)	% Solvent A (0.1% FA in Water)	% Solvent B (ACN)	Phase
0.00	95	5	Equilibration
1.00	95	5	Load
10.00	5	95	Ramp
12.00	5	95	Wash

| 12.10 | 95 | 5 | Re-equilibration |

Validation Steps (The "Self-Check"):

- Mass Confirmation: Look for the parent ion

Da.[\[1\]](#)

- Check: If you see 211.2 Da, you have the wrong standard (non-methylated analog).[\[1\]](#)

- Purity Calculation: Integrate the PDA peak area at 254 nm.

- Formula:

.[\[1\]](#)

- Requirement: Must be >98.0% for use as a quantitative standard.[\[1\]](#)

- Isomer Check: Inspect the baseline for a small shoulder peak immediately following the main peak.[\[1\]](#) This is often the 6-nitro isomer.[\[1\]](#) If >0.5%, the standard requires recrystallization (from boiling water).[\[1\]](#)

Analytical Decision Workflow

Use this logic flow to determine the appropriate analytical technique based on your sensitivity requirements.

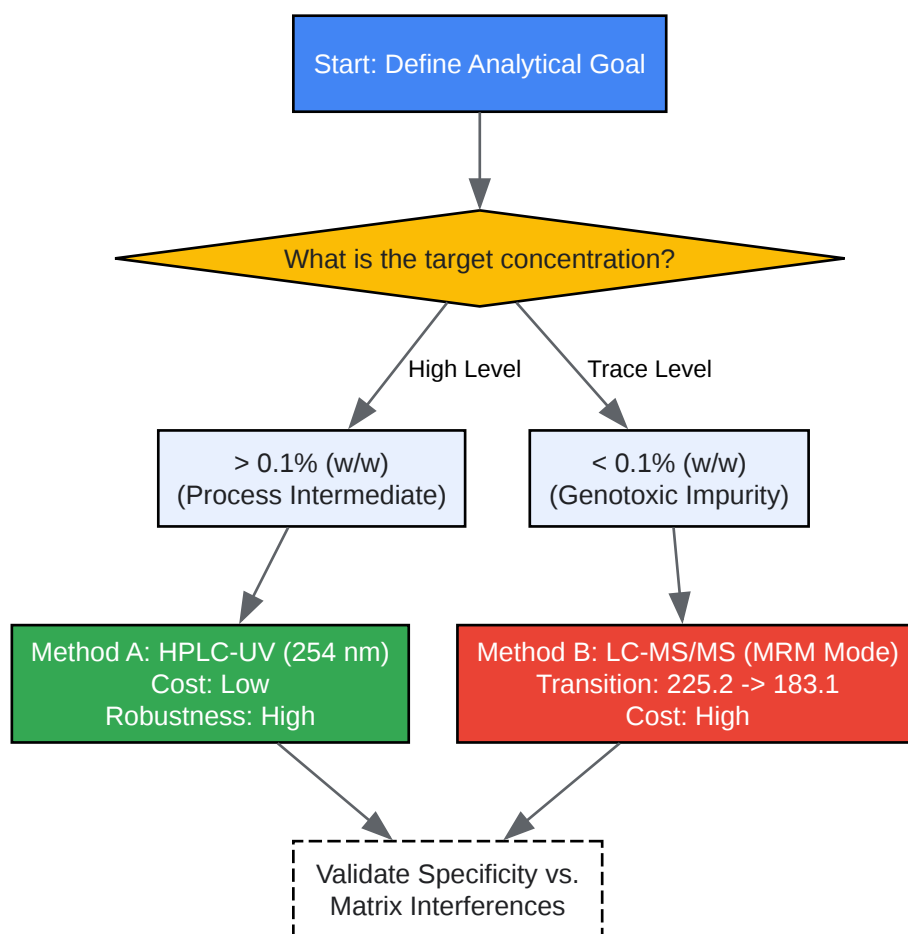

[Click to download full resolution via product page](#)

Figure 2: Decision matrix for selecting the analytical method. HPLC-UV is sufficient for synthesis monitoring, while LC-MS/MS is required for trace impurity analysis due to the potential genotoxicity of nitro-aromatics.

References

- Hines, J. E., et al. (2025). "Crystal structure of **N-(4-methoxy-2-methyl-5-nitrophenyl)acetamide**."^[1]^[4]^[5]^[7] Acta Crystallographica Section E: Crystallographic Communications, 81, 1-4.^[1]
- Uppu, R. M., & Pryor, W. A. (1999). "Synthesis of peroxyxynitrite-derived metabolites of acetaminophen and related compounds."^[1] Chemical Research in Toxicology, 12(11).^[1] (Contextual grounding for oxidative metabolites).

- PubChem Database. "**N-(4-Methoxy-2-methyl-5-nitrophenyl)acetamide** Compound Summary (CID 516920886)."[1] National Library of Medicine.[1]
- ICH Expert Working Group. "ICH M7(R1): Assessment and Control of DNA Reactive (Mutagenic) Impurities in Pharmaceuticals." International Council for Harmonisation.[1] (Regulatory context for nitro-impurity control).

Need Custom Synthesis?

BenchChem offers custom synthesis for rare earth carbides and specific isotopic labeling.

Email: info@benchchem.com or [Request Quote Online](#).

Sources

- 1. [rsc.org](https://www.rsc.org) [[rsc.org](https://www.rsc.org)]
- 2. [N-\(4-Methoxy-2-nitrophenyl\)acetamide | 119-81-3 | Benchchem](#) [[benchchem.com](https://www.benchchem.com)]
- 3. [CAS 119-81-3 N-\(4-Methoxy-2-nitrophenyl\)acetamide Impurity | Impurity Manufacturers & Suppliers India](#) [[anantlabs.com](https://www.anantlabs.com)]
- 4. [N-\(4-Methoxy-2-methyl-5-nitrophenyl\)acetamide - PMC](#) [[pmc.ncbi.nlm.nih.gov](https://pubmed.ncbi.nlm.nih.gov)]
- 5. journals.iucr.org [journals.iucr.org]
- 6. journals.iucr.org [journals.iucr.org]
- 7. [researchgate.net](https://www.researchgate.net) [[researchgate.net](https://www.researchgate.net)]
- To cite this document: BenchChem. [Technical Reference Guide: N-(4-Methoxy-2-methyl-5-nitrophenyl)acetamide Standards]. BenchChem, [2026]. [Online PDF]. Available at: [<https://www.benchchem.com/product/b1646823/docs#technical-reference-guide-n-4-methoxy-2-methyl-5-nitrophenyl-acetamide-standards>]

Disclaimer & Data Validity:

The information provided in this document is for Research Use Only (RUO) and is strictly not intended for diagnostic or therapeutic procedures. While BenchChem strives to provide accurate protocols, we make no warranties, express or implied, regarding the fitness of this product for every specific experimental setup.

Technical Support: The protocols provided are for reference purposes. Unsure if this reagent suits your experiment?

Need Industrial/Bulk Grade? [Request Custom Synthesis Quote](#)

BenchChem

Our mission is to be the trusted global source of essential and advanced chemicals, empowering scientists and researchers to drive progress in science and industry.

Contact

Address: 3281 E Guasti Rd
Ontario, CA 91761, United States
Phone: (601) 213-4426
Email: info@benchchem.com

[Contact our Ph.D. Support Team for a compatibility check](#)