

silver-copper alloy system fundamentals

Author: BenchChem Technical Support Team. **Date:** May 2026

Compound of Interest

Compound Name:	Silver-copper
CAS No.:	12249-45-5
Cat. No.:	B1645152

[Get Quote](#)

An In-Depth Technical Guide to the **Silver-Copper** (Ag-Cu) Alloy System

Introduction

The **silver-copper** (Ag-Cu) system is a classic binary eutectic alloy that has been utilized for centuries, from coinage and decorative arts to modern industrial applications in electronics and brazing. The combination of silver's high electrical and thermal conductivity with copper's strength and cost-effectiveness allows for the creation of alloys with a wide range of tailored properties.^{[1][2]} This guide provides a fundamental overview of the Ag-Cu system, focusing on its phase equilibria, physical and mechanical properties, and the standard experimental protocols used for its characterization. This document is intended for materials scientists, researchers, and engineers seeking a technical understanding of this important alloy system.

Phase Equilibria and Microstructure

The relationship between temperature, composition, and the phases present at equilibrium in the Ag-Cu system is described by the Ag-Cu phase diagram. This system is characterized by a simple eutectic reaction, where a single liquid phase transforms into two distinct solid phases upon cooling.

The two solid phases are:

- Alpha (α) phase: A terminal solid solution of copper dissolved in silver with a Face-Centered Cubic (FCC) crystal structure.[3]
- Beta (β) phase: A terminal solid solution of silver dissolved in copper, also with an FCC crystal structure.[3]

Silver and copper exhibit limited solid solubility in each other.[4] The maximum solubility of copper in silver (in the α phase) is 8.8% by weight at the eutectic temperature, while the maximum solubility of silver in copper (in the β phase) is 8.0% by weight, also at the eutectic temperature.[1][5][6]

The most significant feature of the phase diagram is the eutectic point. At a specific composition and temperature, the liquid phase transforms directly into a fine mixture of the α and β solid phases. This eutectic reaction creates a distinctive lamellar (layered) microstructure.

Data Presentation: Key Features of the Ag-Cu Phase Diagram

The critical quantitative data points of the Ag-Cu phase diagram are summarized in the table below for easy reference.

Property	Value (Composition in wt. %)	Value (°C)	Value (°F)
Melting Point of Pure Silver (Ag)	100% Ag	960.5 °C[7]	1761 °F[7]
Melting Point of Pure Copper (Cu)	100% Cu	1083 °C	1981 °F
Eutectic Composition	71.9% Ag / 28.1% Cu[6][7][8]	-	-
Eutectic Temperature	-	779 °C[1][8][9]	1434 °F
Max. Solid Solubility of Cu in Ag (α)	8.8% Cu in Ag[1][9]	779 °C[1][9]	1434 °F
Max. Solid Solubility of Ag in Cu (β)	8.0% Ag in Cu[1][5][6]	779 °C[1]	1434 °F

Visualization: Ag-Cu Phase Diagram

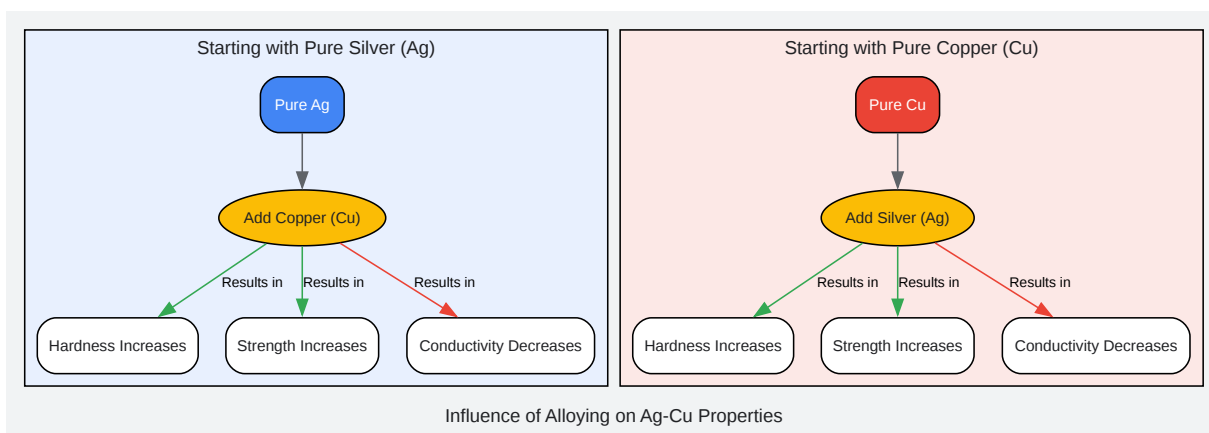
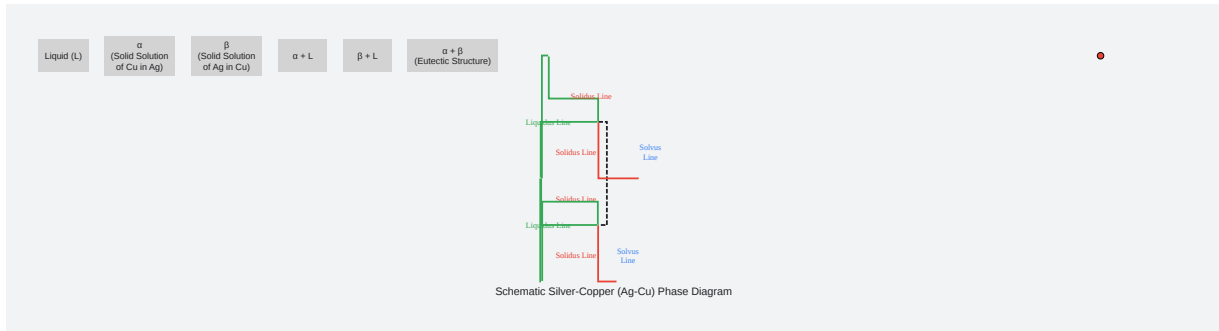

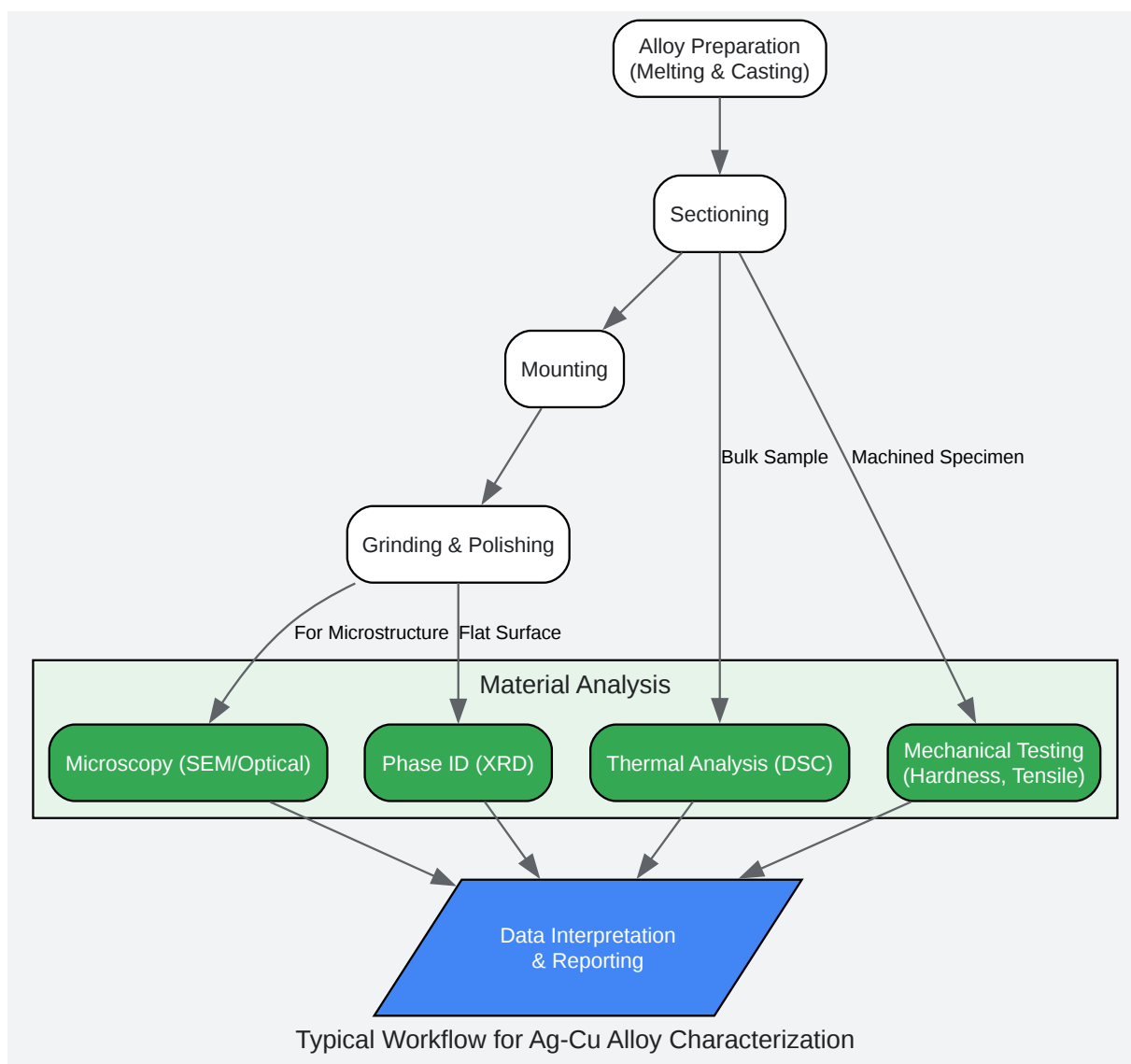

[Click to download full resolution via product page](#)

Need Custom Synthesis?

BenchChem offers custom synthesis for rare earth carbides and specific isotopic labeling.

Email: info@benchchem.com or [Request Quote Online](#).

References

- [1. store.astm.org \[store.astm.org\]](https://store.astm.org)
- [2. researchgate.net \[researchgate.net\]](https://researchgate.net)
- [3. Metallographic Preparation of Copper and Copper Alloys - Metkon \[metkon.com\]](https://www.metkon.com)
- [4. ieomsociety.org \[ieomsociety.org\]](https://www.ieomsociety.org)
- [5. reddit.com \[reddit.com\]](https://www.reddit.com)
- [6. materials.ox.ac.uk \[materials.ox.ac.uk\]](https://materials.ox.ac.uk)
- [7. chemetalusa.com \[chemetalusa.com\]](https://www.chemetalusa.com)
- [8. domadia.net \[domadia.net\]](https://www.domadia.net)
- [9. Metallographic Investigations of Silver Alloys Used for Minting | Scientific.Net \[scientific.net\]](https://www.scientific.net)
- To cite this document: BenchChem. [silver-copper alloy system fundamentals]. BenchChem, [2026]. [Online PDF]. Available at: [\[https://www.benchchem.com/product/b1645152/docs#silver-copper-alloy-system-fundamentals\]](https://www.benchchem.com/product/b1645152/docs#silver-copper-alloy-system-fundamentals)

Disclaimer & Data Validity:

The information provided in this document is for Research Use Only (RUO) and is strictly not intended for diagnostic or therapeutic procedures. While BenchChem strives to provide accurate protocols, we make no warranties, express or implied, regarding the fitness of this product for every specific experimental setup.

Technical Support: The protocols provided are for reference purposes. Unsure if this reagent suits your experiment?

Need Industrial/Bulk Grade? [Request Custom Synthesis Quote](#)

BenchChem

Our mission is to be the trusted global source of essential and advanced chemicals, empowering scientists and researchers to drive progress in science and industry.

Contact

Address: 3281 E Guasti Rd

Ontario, CA 91761, United States

Phone: (601) 213-4426

Email: info@benchchem.com

[Contact our Ph.D. Support Team for a compatibility check](#)