

In vitro assays for evaluating the anticancer potency of pyrazole compounds

Author: BenchChem Technical Support Team. **Date:** April 2026

Compound of Interest

Compound Name: 4-formyl-1H-Pyrazole-3-carboxamide

Cat. No.: B1642891

[Get Quote](#)

Application Notes and Protocols

Topic: In Vitro Assays for Evaluating the Anticancer Potency of Pyrazole Compounds

Audience: Researchers, scientists, and drug development professionals.

Introduction: The Pyrazole Scaffold as a Cornerstone in Anticancer Drug Discovery

The pyrazole ring system is a "privileged scaffold" in medicinal chemistry, forming the structural core of numerous compounds with a wide spectrum of pharmacological activities.^{[1][2]} In oncology, pyrazole derivatives have been successfully developed into clinically approved drugs, such as Crizotinib and Sorafenib, highlighting their therapeutic potential.^[3] These compounds exert their anticancer effects through diverse and targeted mechanisms, including the inhibition of key signaling pathways, induction of programmed cell death (apoptosis), and disruption of the cell cycle.^{[1][2][4]}

This guide provides a comprehensive framework for the in vitro evaluation of novel pyrazole compounds. It is designed to take researchers from initial cytotoxicity screening to in-depth mechanistic elucidation, ensuring that the anticancer potential of each candidate is characterized with scientific rigor. The narrative follows a logical, tiered approach, explaining not just the "how" but the "why" behind each experimental choice, empowering researchers to build a robust data package for their lead compounds.

An Integrated Workflow for Characterizing Pyrazole Anticancer Candidates

A systematic, multi-assay approach is crucial for efficiently identifying and validating potent anticancer compounds. The workflow should begin with broad screening to assess general cytotoxicity and then funnel promising candidates into more specific assays to determine their mechanism of action (MoA).

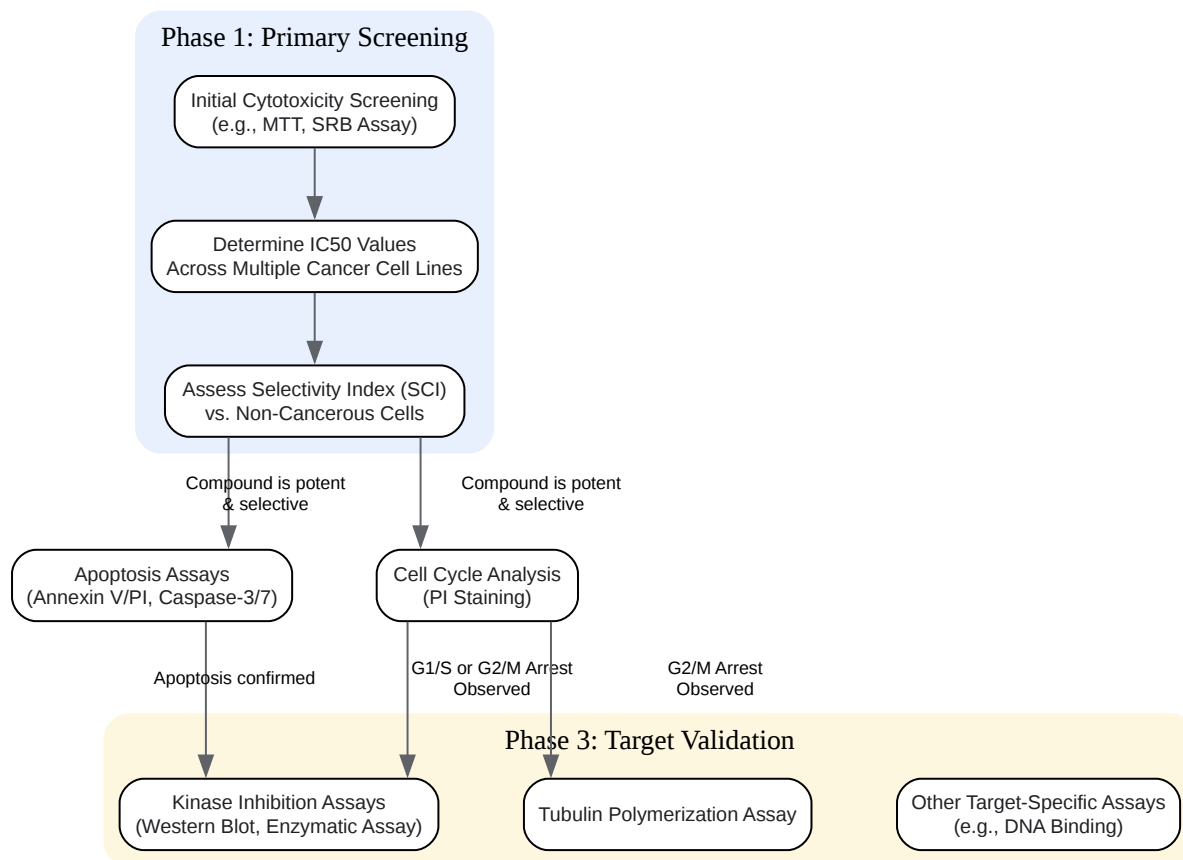

[Click to download full resolution via product page](#)

Caption: Integrated workflow for the in vitro evaluation of pyrazole compounds.

Part 1: Primary Screening – The Litmus Test for Cytotoxicity

Causality: The foundational step in evaluating any potential anticancer agent is to determine its ability to inhibit the growth of cancer cells. This primary screen acts as a gatekeeper, identifying compounds with significant biological activity and establishing the precise concentration range

(the IC₅₀ value) at which they are effective. This data is critical for designing all subsequent mechanistic experiments.

Key Assay: MTT (3-(4,5-dimethylthiazol-2-yl)-2,5-diphenyltetrazolium bromide) Assay

The MTT assay is a colorimetric method for assessing cell metabolic activity, which serves as a proxy for cell viability.^[5] In viable cells, mitochondrial reductase enzymes convert the yellow tetrazolium salt (MTT) into purple formazan crystals. The amount of formazan produced is proportional to the number of living cells, allowing for the quantification of cytotoxicity.

Protocol 1: MTT Cytotoxicity Assay

Objective: To determine the half-maximal inhibitory concentration (IC₅₀) of a pyrazole compound.

Materials:

- Cancer cell lines (e.g., MCF-7 for breast, A549 for lung, HCT-116 for colon) and a non-cancerous control (e.g., MCF-10A).^{[6][7]}
- Complete culture medium (e.g., DMEM, RPMI-1640) with 10% FBS.
- 96-well flat-bottom plates.
- Pyrazole compound stock solution (e.g., 10 mM in DMSO).
- MTT reagent (5 mg/mL in PBS).
- Solubilization buffer (e.g., DMSO or a solution of 10% SDS in 0.01 M HCl).
- Multichannel pipette and a microplate reader (570 nm).

Procedure:

- Cell Seeding: Trypsinize and count cells. Seed 5,000-10,000 cells per well in 100 μ L of complete medium into a 96-well plate. Incubate for 24 hours at 37°C, 5% CO₂ to allow for cell attachment.

- **Compound Treatment:** Prepare serial dilutions of the pyrazole compound in complete medium. Remove the old medium from the plate and add 100 μ L of the compound dilutions to the respective wells. Include a vehicle control (e.g., 0.1% DMSO) and a no-cell blank.
- **Incubation:** Incubate the plate for 48-72 hours at 37°C, 5% CO₂.
- **MTT Addition:** Add 20 μ L of MTT reagent to each well and incubate for 3-4 hours at 37°C, allowing formazan crystals to form.
- **Solubilization:** Carefully remove the medium and add 100 μ L of DMSO to each well. Pipette up and down to dissolve the formazan crystals.
- **Data Acquisition:** Measure the absorbance at 570 nm using a microplate reader.
- **Analysis:** Convert absorbance values to percentage of cell viability relative to the vehicle control. Plot the percentage viability against the log of the compound concentration and use non-linear regression to calculate the IC₅₀ value.

Trustworthiness: A robust assay includes multiple replicates ($n \geq 3$) and appropriate controls. The IC₅₀ values should be reproducible across independent experiments. It is also crucial to test the compounds on a non-cancerous cell line to calculate a Selective Cytotoxicity Index (SCI), which indicates the compound's specificity for cancer cells.[7]

Data Presentation: Summarizing Cytotoxicity

Quantitative data should be organized into a clear table to compare the potency of different compounds across various cell lines.

| Compound | IC ₅₀ (μ M) vs. MCF-7 (Breast) | IC ₅₀ (μ M) vs. A549 (Lung) | IC ₅₀ (μ M) vs. HCT-116 (Colon) | IC ₅₀ (μ M) vs. MCF- 10A (Non- cancerous) | SCI (MCF-7) |
|-------------|--|---|---|--|-------------|
| Pyrazole-A | 5.2 \pm 0.4 | 8.1 \pm 0.9 | 6.5 \pm 0.7 | 45.3 \pm 3.1 | 8.7 |
| Pyrazole-B | 12.8 \pm 1.1 | 15.3 \pm 2.0 | 10.1 \pm 1.3 | 21.5 \pm 2.5 | 1.7 |
| Doxorubicin | 0.8 \pm 0.1 | 1.2 \pm 0.2 | 0.9 \pm 0.1 | 5.1 \pm 0.6 | 6.4 |

Data are presented as mean \pm SD. SCI = IC50 (Non-cancerous) / IC50 (Cancerous). A higher SCI value indicates greater selectivity.[7]

Part 2: Mechanistic Elucidation – Unveiling the "How"

Once a compound demonstrates potent and selective cytotoxicity, the focus shifts to understanding its mechanism of action. For pyrazole compounds, the most common mechanisms involve the induction of apoptosis and/or cell cycle arrest.

Induction of Apoptosis

Causality: A key goal of cancer therapy is to trigger programmed cell death, or apoptosis, in malignant cells. Assays that detect the hallmark features of apoptosis provide direct evidence of a compound's ability to engage this critical cell death pathway. Early markers include the externalization of phosphatidylserine (PS), while later events include the activation of executioner caspases.[8][9]

Key Assay: Annexin V-FITC / Propidium Iodide (PI) Staining

This flow cytometry-based assay is the gold standard for differentiating between healthy, early apoptotic, late apoptotic, and necrotic cells.[3][5] Annexin V is a protein that binds with high affinity to PS, which is translocated from the inner to the outer leaflet of the plasma membrane during early apoptosis.[10] PI is a fluorescent nucleic acid stain that cannot cross the membrane of live or early apoptotic cells, but can enter late apoptotic and necrotic cells where membrane integrity is compromised.[3]

Protocol 2: Annexin V/PI Apoptosis Assay

Objective: To quantify the percentage of cells undergoing apoptosis after treatment with a pyrazole compound.

Materials:

- Cancer cells treated with the pyrazole compound at its IC50 and 2x IC50 concentrations for 24-48 hours.

- Annexin V-FITC Apoptosis Detection Kit (containing Annexin V-FITC, PI, and a binding buffer).[10]
- Flow cytometer.

Procedure:

- Cell Treatment & Harvesting: Treat cells as planned. After incubation, harvest both adherent and floating cells. Centrifuge at 300 x g for 5 minutes.
- Washing: Discard the supernatant and wash the cell pellet twice with ice-cold PBS.
- Resuspension: Resuspend the cells in 100 μL of 1X Binding Buffer. The cell concentration should be approximately 1×10^6 cells/mL.
- Staining: Add 5 μL of Annexin V-FITC and 5 μL of PI solution to the cell suspension.[3]
- Incubation: Gently vortex the cells and incubate for 15 minutes at room temperature in the dark.
- Dilution: Add 400 μL of 1X Binding Buffer to each tube.
- Data Acquisition: Analyze the samples by flow cytometry within one hour. Use FITC (FL1) and PI (FL2) channels.

Data Interpretation:

- Lower-Left Quadrant (Annexin V- / PI-): Live cells.
- Lower-Right Quadrant (Annexin V+ / PI-): Early apoptotic cells.[3]
- Upper-Right Quadrant (Annexin V+ / PI+): Late apoptotic/necrotic cells.[3]
- Upper-Left Quadrant (Annexin V- / PI+): Necrotic cells.

Cell Cycle Disruption

Causality: Uncontrolled cell proliferation is a defining feature of cancer, often caused by dysregulation of the cell cycle. Many pyrazole-based drugs function as kinase inhibitors that

target cyclin-dependent kinases (CDKs), which are master regulators of cell cycle progression. [4][11][12] Forcing a cancer cell to arrest at a specific phase of the cell cycle (e.g., G1, S, or G2/M) prevents it from dividing and can ultimately lead to apoptosis.

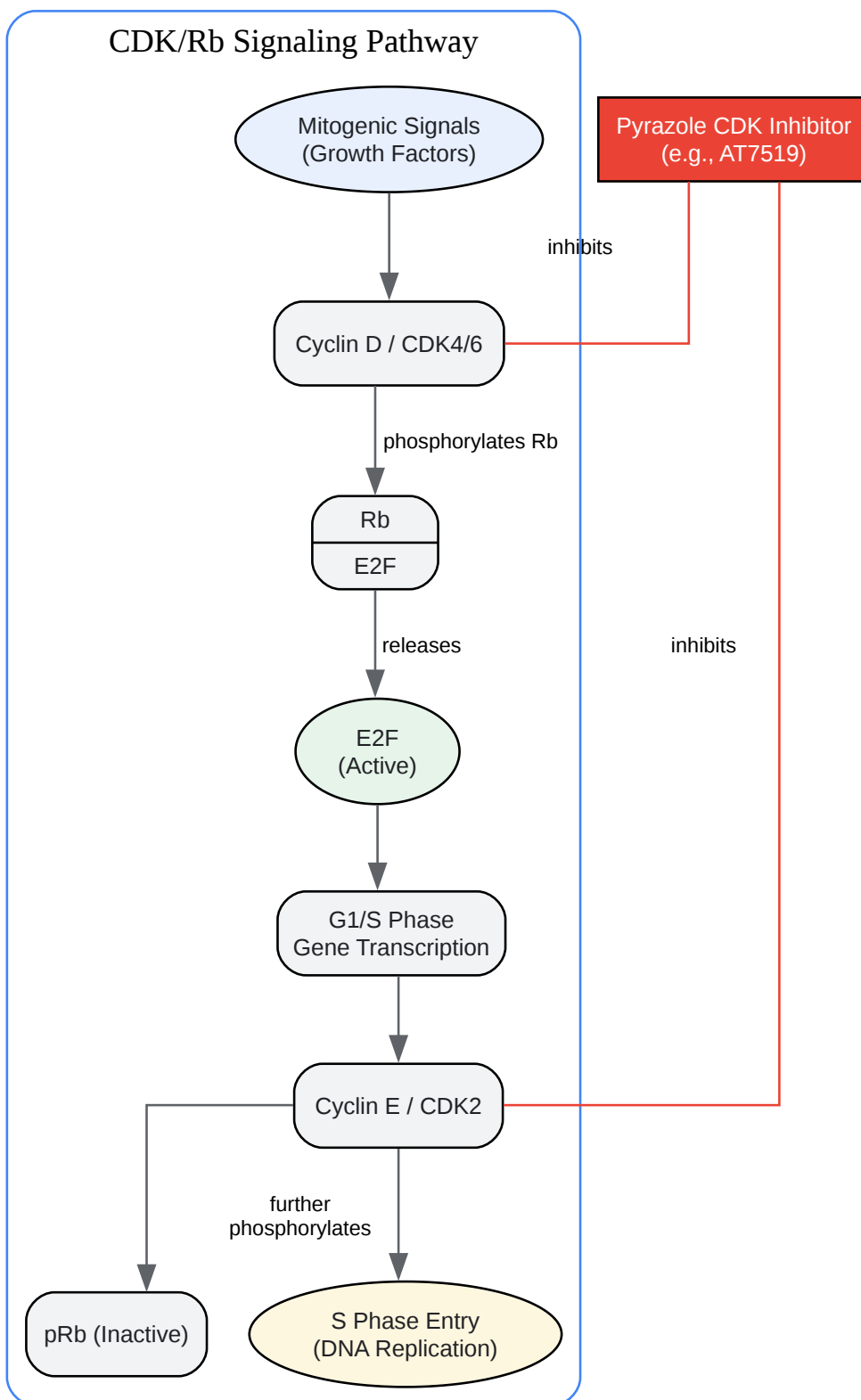

[Click to download full resolution via product page](#)

Caption: Inhibition of the CDK/Rb pathway by pyrazole compounds.

Key Assay: Propidium Iodide (PI) Staining for DNA Content

This method uses PI to stain cellular DNA.^[3] Because the amount of DNA doubles as a cell moves from the G1 to the G2/M phase, the intensity of PI fluorescence is directly proportional to the DNA content. Flow cytometry can then be used to generate a histogram that reveals the distribution of the cell population across the different phases of the cell cycle.

Protocol 3: Cell Cycle Analysis by PI Staining

Objective: To determine the effect of a pyrazole compound on cell cycle distribution.

Materials:

- Cancer cells treated with the pyrazole compound at relevant concentrations.
- 70% ethanol (ice-cold).
- PI Staining Solution (e.g., 50 µg/mL PI and 100 µg/mL RNase A in PBS).^[3]
- Flow cytometer.

Procedure:

- Cell Harvesting: Collect cells (including supernatant) and wash once with PBS.
- Fixation: Resuspend the cell pellet in 500 µL of PBS. While gently vortexing, add 4.5 mL of ice-cold 70% ethanol dropwise to fix the cells.
- Storage: Incubate at -20°C for at least 2 hours (or overnight).^[12]
- Staining: Centrifuge the fixed cells and discard the ethanol. Wash the pellet once with PBS. Resuspend in 0.5 mL of PI Staining Solution.
- Incubation: Incubate in the dark at room temperature for 30 minutes.
- Data Acquisition: Analyze the stained cells using a flow cytometer, collecting data for at least 10,000 events.

- Analysis: Use cell cycle analysis software (e.g., ModFit, FlowJo) to deconvolute the DNA content histogram and quantify the percentage of cells in the Sub-G1 (apoptotic), G0/G1, S, and G2/M phases.

Part 3: Target Validation – Pinpointing the Molecular Interaction

Causality: Results from the mechanistic assays often point toward a specific molecular target or pathway. For instance, G2/M arrest may suggest inhibition of tubulin polymerization, while G1 arrest points towards CDK4/6 or CDK2 inhibition.[11][12][13] Target validation assays are essential to confirm these hypotheses and provide direct evidence of the compound's molecular interaction.

Key Assay: Western Blotting for Kinase Pathway Inhibition

Western blotting is a powerful technique to assess the activity of a signaling pathway by measuring the phosphorylation status of key proteins. For a pyrazole compound hypothesized to inhibit a specific kinase (e.g., EGFR, AKT, ERK), a western blot can confirm this by showing a decrease in the phosphorylation of its downstream substrate.[3][14]

Protocol 4: Western Blotting for Phospho-Protein Analysis

Objective: To determine if a pyrazole compound inhibits a target kinase pathway.

Materials:

- Cells treated with the pyrazole inhibitor at various concentrations.
- Ice-cold lysis buffer (e.g., RIPA buffer) with protease and phosphatase inhibitors.
- BCA Protein Assay Kit.
- SDS-PAGE gels, running buffer, and transfer buffer.
- PVDF membrane.

- Blocking buffer (e.g., 5% non-fat milk or BSA in TBST).
- Primary antibodies (e.g., anti-phospho-EGFR, anti-total-EGFR, anti-Actin).
- HRP-conjugated secondary antibody.
- Chemiluminescent substrate (ECL).
- Imaging system.

Procedure:

- Protein Extraction: After treatment, wash cells with ice-cold PBS and lyse them with lysis buffer.[\[12\]](#)
- Quantification: Determine protein concentration using the BCA assay.
- SDS-PAGE: Denature 20-30 µg of protein per sample and separate by SDS-PAGE.
- Transfer: Transfer the separated proteins to a PVDF membrane.
- Blocking: Block the membrane for 1 hour at room temperature in blocking buffer.
- Primary Antibody Incubation: Incubate the membrane with the primary antibody (e.g., anti-phospho-protein) overnight at 4°C.
- Secondary Antibody Incubation: Wash the membrane with TBST and incubate with the HRP-conjugated secondary antibody for 1 hour at room temperature.
- Detection: Wash again, apply the ECL substrate, and capture the chemiluminescent signal with an imaging system.
- Stripping & Reprobing: The membrane can be stripped and reprobed with antibodies for the total protein and a loading control (e.g., Actin) to ensure equal protein loading.

Trustworthiness: The key to a reliable western blot is demonstrating a dose-dependent decrease in the phosphorylated protein relative to the total protein and the loading control. This provides strong evidence that the compound is engaging its intended target within the cell.

References

- Recent Advances in the Development of Pyrazole Derivatives as Anticancer Agents. National Center for Biotechnology Information (PMC). Available from: [\[Link\]](#)
- Synthesis and Biological Activities of Novel Pyrazole Derivatives in the Management of Cancer. Hilaris Publisher. Available from: [\[Link\]](#)
- Design, Synthesis, Anticancer Evaluation, Enzymatic Assays, and a Molecular Modeling Study of Novel Pyrazole–Indole Hybrids. National Center for Biotechnology Information (PMC). Available from: [\[Link\]](#)
- Mechanisms and anticancer therapeutic potential of 1,3,4-trisubstituted pyrazole derivatives (mini review). Novelty Journals. Available from: [\[Link\]](#)
- Design, synthesis and biological evaluation of novel pyrazole-based compounds as potential chemotherapeutic agents. National Center for Biotechnology Information (PMC). Available from: [\[Link\]](#)
- Synthesis, Characterization and Mechanistic Anticancer Evaluation of Novel Analogues of Pyrazoles Derived from Substituted 3-acetyl coumarin. Semantic Scholar. Available from: [\[Link\]](#)
- Derivatives of Pyrazole-Based Compounds as Prospective Cancer Agents. National Center for Biotechnology Information (PMC). Available from: [\[Link\]](#)
- Synthesis of Novel Pyrazole Derivatives and Their Tumor Cell Growth Inhibitory Activity. MDPI. Available from: [\[Link\]](#)
- Design, synthesis and biological evaluation of novel pyrazole-based compounds as potential chemotherapeutic agents. Taylor & Francis Online. Available from: [\[Link\]](#)
- Derivatives of pyrazole-based compounds as prospective cancer agents. UWCScholar. Available from: [\[Link\]](#)
- Design, Synthesis, Anticancer Evaluation, Enzymatic Assays, and a Molecular Modeling Study of Novel Pyrazole–Indole Hybrids. ACS Publications. Available from: [\[Link\]](#)

- Pyrazoles as anticancer agents: Recent advances. SRR Publications. Available from: [\[Link\]](#)
- Novel Anticancer Fused Pyrazole Derivatives as EGFR and VEGFR-2 Dual TK Inhibitors. Frontiers in Chemistry. Available from: [\[Link\]](#)
- A Novel Pyrazole Exhibits Potent Anticancer Cytotoxicity via Apoptosis, Cell Cycle Arrest, and the Inhibition of Tubulin Polymerization in Triple-Negative Breast Cancer Cells. National Center for Biotechnology Information (PMC). Available from: [\[Link\]](#)
- Pyrazole Derivatives Induce Apoptosis via ROS Generation in the Triple Negative Breast Cancer Cells, MDA-MB-468. Research Square. Available from: [\[Link\]](#)
- Ultrasound-assisted synthesis and anticancer evaluation of new pyrazole derivatives as cell cycle inhibitors. Arabian Journal of Chemistry. Available from: [\[Link\]](#)
- Pyrazole Derivatives Induce Apoptosis via ROS Generation in the Triple Negative Breast Cancer Cells, MDA-MB-468. National Center for Biotechnology Information (PMC). Available from: [\[Link\]](#)
- Design, synthesis and in vitro cytotoxicity evaluation of indolo-pyrazoles grafted with thiazolidinone as tubulin polymerization inhibitors. National Center for Biotechnology Information (PMC). Available from: [\[Link\]](#)
- Kinase Inhibitory Activities and Molecular Docking of a Novel Series of Anticancer Pyrazole Derivatives. PubMed. Available from: [\[Link\]](#)
- Recent advances in the synthesis of anticancer pyrazole derivatives using microwave, ultrasound, and mechanochemical techniques. RSC Publishing. Available from: [\[Link\]](#)
- Design, Synthesis, Anticancer Evaluation, Enzymatic Assays, and a Molecular Modeling Study of Novel Pyrazole-Indole. Semantic Scholar. Available from: [\[Link\]](#)
- Discovery of pyrazole-based analogs as CDK2 inhibitors with apoptotic-inducing activity: design, synthesis and molecular dynamics study. RSC Publishing. Available from: [\[Link\]](#)
- Discovery of 3-Amino-1H-pyrazole-Based Kinase Inhibitors to Illuminate the Understudied PCTAIRE Family. MDPI. Available from: [\[Link\]](#)

- Annexin V-FITC Apoptosis Assay Kit. ImmunoChemistry Technologies. Available from: [\[Link\]](#)
- Choosing an Apoptosis Detection Assay. Axion Biosystems. Available from: [\[Link\]](#)
- Incucyte® Apoptosis Assays for Live-Cell Analysis. Sartorius. Available from: [\[Link\]](#)

Need Custom Synthesis?

BenchChem offers custom synthesis for rare earth carbides and specific isotopic labeling.

Email: info@benchchem.com or [Request Quote Online](#).

Sources

1. Recent Advances in the Development of Pyrazole Derivatives as Anticancer Agents - PMC [pmc.ncbi.nlm.nih.gov]
2. noveltyjournals.com [noveltyjournals.com]
3. benchchem.com [benchchem.com]
4. hilarispublisher.com [hilarispublisher.com]
5. Pyrazole Derivatives Induce Apoptosis via ROS Generation in the Triple Negative Breast Cancer Cells, MDA-MB-468 - PMC [pmc.ncbi.nlm.nih.gov]
6. pubs.acs.org [pubs.acs.org]
7. pmc.ncbi.nlm.nih.gov [pmc.ncbi.nlm.nih.gov]
8. Choosing an Apoptosis Detection Assay | Axion Biosystems [axionbiosystems.com]
9. Incucyte® Apoptosis Assays for Live-Cell Analysis | Sartorius [sartorius.com]
10. fnkprddata.blob.core.windows.net [fnkprddata.blob.core.windows.net]
11. Ultrasound-assisted synthesis and anticancer evaluation of new pyrazole derivatives as cell cycle inhibitors - Arabian Journal of Chemistry [arabjchem.org]
12. pdf.benchchem.com [pdf.benchchem.com]
13. mdpi.com [mdpi.com]
14. Kinase Inhibitory Activities and Molecular Docking of a Novel Series of Anticancer Pyrazole Derivatives - PubMed [pubmed.ncbi.nlm.nih.gov]

- To cite this document: BenchChem. [In vitro assays for evaluating the anticancer potency of pyrazole compounds]. BenchChem, [2026]. [Online PDF]. Available at: [<https://www.benchchem.com/product/b1642891/docs#in-vitro-assays-for-evaluating-the-anticancer-potency-of-pyrazole-compounds>]

Disclaimer & Data Validity:

The information provided in this document is for Research Use Only (RUO) and is strictly not intended for diagnostic or therapeutic procedures. While BenchChem strives to provide accurate protocols, we make no warranties, express or implied, regarding the fitness of this product for every specific experimental setup.

Technical Support: The protocols provided are for reference purposes. Unsure if this reagent suits your experiment?

Need Industrial/Bulk Grade? [Request Custom Synthesis Quote](#)

BenchChem

Our mission is to be the trusted global source of essential and advanced chemicals, empowering scientists and researchers to drive progress in science and industry.

Contact

Address: 3281 E Guasti Rd
Ontario, CA 91761, United States
Phone: (601) 213-4426
Email: info@benchchem.com

[Contact our Ph.D. Support Team for a compatibility check](#)