

Technical Guide: Hyponitrite Initiators in High-Value Polymer Synthesis

Author: BenchChem Technical Support Team. **Date:** April 2026

Compound of Interest

Compound Name: *trans-Di-tert-butylhyponitrite*

CAS No.: 82554-97-0

Cat. No.: B1638041

[Get Quote](#)

Executive Summary: The Case for Switching

In the synthesis of pharmaceutical-grade polymers and bio-conjugates, the choice of radical initiator is often treated as a commodity decision—typically defaulting to AIBN (2,2'-Azobis(isobutyronitrile)) due to cost and familiarity. However, for high-value applications requiring low-temperature processing and rigorous biocompatibility, AIBN presents critical failure modes:

- **Toxic Residues:** AIBN decomposition yields tetramethylsuccinonitrile (TMSN), a neurotoxic nitrile that is difficult to remove.
- **Thermal Stress:** The 10-hour half-life temperature () of 65°C is often too high for protein-polymer conjugates or volatile monomers.^[1]

Di-tert-butyl hyponitrite (TBHN) offers a superior thermodynamic and toxicological profile.^[1] With a

of approximately 45°C and "clean" decomposition into acetone and tert-butanol, it allows for room-temperature initiation and FDA-compliant byproduct profiles.[1] This guide details the mechanistic superiority and practical application of TBHN.

Mechanistic & Kinetic Comparison

The fundamental advantage of TBHN lies in its decomposition pathway. Unlike azo compounds which generate carbon-centered radicals stabilized by toxic cyano groups, hyponitrites generate oxygen-centered alkoxy radicals.[1]

Decomposition Pathways (Visualized)

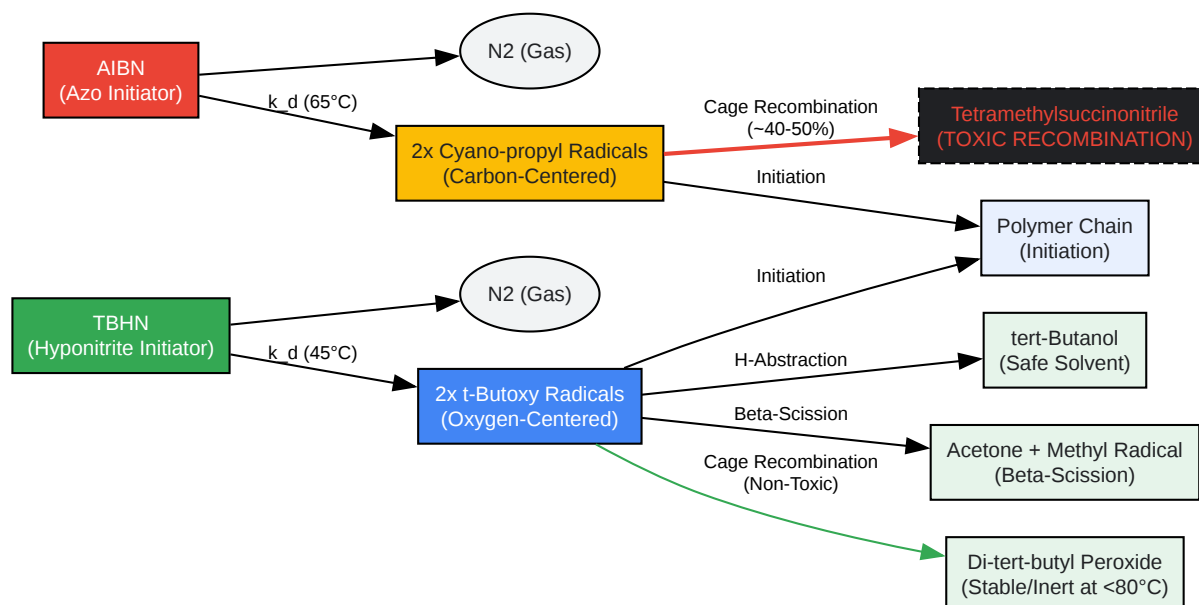

[Click to download full resolution via product page](#)

Figure 1: Comparative decomposition pathways. Note AIBN's recombination leads to toxic TMSN, whereas TBHN's recombination leads to stable, inert di-tert-butyl peroxide (DTBP).

Kinetic Data Summary

The following table contrasts the physical properties critical for process design.

Parameter	AIBN (Standard)	TBHN (Advanced)	Impact
Radical Type	Carbon-centered (C[1]•)	Oxygen-centered (O[1]•)	O• is more electrophilic; higher H-abstraction capability. [1]
(10h Half-Life)	65°C	~45°C	TBHN enables polymerization at 20–40°C.
Activation Energy ()	~129 kJ/mol	~103 kJ/mol	TBHN is more sensitive to temperature changes; easier to trigger. [1]
Cage Efficiency ()	0.5 – 0.6	0.66 (in PhCl)	Higher means less "wasted" initiator and fewer termination byproducts.
Primary Byproduct	Tetramethylsuccinonitrile	tert-Butanol / Acetone	Crucial: TBHN residues are Class 3 solvents (low tox) vs. AIBN's toxic nitrile. [1]
Recombination Product	Toxic Nitrile (TMSN)	Di-tert-butyl Peroxide	DTBP is stable at 40°C and does not re-initiate or poison the reaction. [1]

Critical Advantages in Application

The "Nitrile-Free" Advantage for Pharma

For drug delivery systems (e.g., PEGylation, hydrogels), regulatory bodies (FDA/EMA) scrutinize residual impurities.

- AIBN Issue: The recombination product, TMSN, is a convulsant. Removing it requires rigorous purification (precipitation/dialysis) which can degrade sensitive polymer-drug conjugates.[1]
- TBHN Solution: The byproducts are volatile solvents (acetone, t-butanol) easily removed by standard vacuum drying.[1] The recombination product (DTBP) is chemically inert at physiological temperatures.

Low-Temperature Initiation

Many bio-active monomers (peptides, acrylates with ester-linked drugs) degrade or crosslink uncontrollably above 50°C.[1]

- Protocol: TBHN allows polymerization at 25°C – 40°C.
- Result: Preservation of monomer bioactivity and suppression of thermally induced auto-polymerization (gelation).[1]

Oxygen-Centered Radical Efficiency

Alkoxy radicals (t-BuO[1]•) are highly reactive toward C=C double bonds but also prone to hydrogen abstraction.

- Benefit: In grafting applications (e.g., grafting onto polysaccharides), the high H-abstraction ability of t-BuO[1]• creates radical sites on the backbone more efficiently than the stabilized cyano-propyl radical of AIBN.[1]

Experimental Protocol: Low-Temperature Polymerization of MMA

Objective: Synthesize Poly(methyl methacrylate) (PMMA) at 40°C to demonstrate low-temperature efficiency and high molecular weight control using TBHN.

Materials

- Monomer: Methyl Methacrylate (MMA), purified to remove inhibitor.

- Initiator: trans-Di-tert-butyl hyponitrite (TBHN).^[1] Note: Store TBHN at -20°C. It is sensitive to shock and heat.^[1]
- Solvent: Benzene (Standard for kinetics) or Ethyl Acetate (Green alternative).
- Atmosphere: High-purity Nitrogen or Argon.^[1]

Step-by-Step Methodology

- Preparation of Ampoule:
 - In a glovebox or under active nitrogen flow, charge a clean, dry glass ampoule with MMA (10.0 g, 0.1 mol).
 - Add Solvent (10.0 mL) if solution polymerization is desired (reduces viscosity/trommsdorff effect).
 - Add TBHN (17.4 mg, 0.1 mmol). Targeting $[I]/[M]$ ratio of $\sim 10^{-3}$.
- Degassing (Critical):
 - Oxygen inhibits radical polymerization. Perform 3 cycles of Freeze-Pump-Thaw:
 1. Freeze solution in liquid N₂.
 2. Apply vacuum (<0.1 mmHg) for 10 mins.
 3. Thaw in warm water.
 - Seal the ampoule under vacuum or inert gas.
- Polymerization:
 - Place the sealed ampoule in a thermostated water bath at 40°C ± 0.1°C.
 - Note: At this temperature, AIBN would require weeks to achieve significant conversion. TBHN will proceed efficiently.

- Reaction Time: 4 – 6 hours (depending on target conversion; usually stopped <20% for kinetic studies or run longer for yield).
- Termination & Isolation:
 - Quench the reaction by cooling the ampoule in liquid N₂.
 - Open ampoule and pour contents into a 10-fold excess of cold Methanol (precipitant).
 - Filter the white precipitate (PMMA).
 - Purification: Re-dissolve in minimal THF and re-precipitate in Methanol to remove unreacted monomer and initiator traces.
- Drying:
 - Dry the polymer in a vacuum oven at 40°C overnight.
 - Observation: The resulting polymer is free of yellow discoloration often associated with high-temp peroxide initiation.^[1]

Safety & Handling (TBHN Specifics)

While TBHN produces safer byproducts, the initiator itself is energetic.

- Storage: Must be stored at -20°C or lower. Decomposition can become autocatalytic at room temperature if stored in bulk.
- Shock Sensitivity: Pure TBHN crystals can be shock-sensitive.^[1] Handle with plastic spatulas; avoid metal friction.
- Solution Stability: Once in solution (e.g., in monomer), it is safe to handle at room temperature for short setup periods.

References

- Kinetics & Efficiency
 - Title: Influence of Cage Effects in Directing the Outcome of C–X Bond Forming Reactions.

- Source: ACS Central Science / NIH.
- Data: Confirms TBHN cage efficiency of 0.66 in chlorobenzene.
- TBHN Physical Properties
 - Title: **trans-Di-tert-butylhyponitrite** (Thermochemistry & Structure).[1][2]
 - Source: NIST Chemistry WebBook.[2][3]
 - Data: Enthalpy of sublimation and structural characteriz
 - [1][3]
- AIBN Toxicity
 - Title: Toxicity of Azo Dyes in Pharmaceutical Industry (Context on Azo breakdown products).
 - Source: ResearchG
 - Data: Discusses carcinogenic potential of arom
- Comparative Radical Chemistry
 - Title: Recent Advances in Application of Alkoxy Radical in Organic Synthesis.
 - Source: NIH / PMC.
 - Data: detailed reactivity of alkoxy radicals (H-abstraction vs Beta-scission).[1]

Need Custom Synthesis?

BenchChem offers custom synthesis for rare earth carbides and specific isotopic labeling.

Email: info@benchchem.com or [Request Quote Online](#).

Sources

- [1. lookchem.com](https://www.lookchem.com) [lookchem.com]
- [2. trans-Di-tert-butylhyponitrite](https://webbook.nist.gov) [webbook.nist.gov]
- [3. chemeo.com](https://chemedchem.com) [chemeo.com]

- To cite this document: BenchChem. [Technical Guide: Hyponitrite Initiators in High-Value Polymer Synthesis]. BenchChem, [2026]. [Online PDF]. Available at: [\[https://www.benchchem.com/product/b1638041/docs#technical-guide-hyponitrite-initiators-in-high-value-polymer-synthesis\]](https://www.benchchem.com/product/b1638041/docs#technical-guide-hyponitrite-initiators-in-high-value-polymer-synthesis)

Disclaimer & Data Validity:

The information provided in this document is for Research Use Only (RUO) and is strictly not intended for diagnostic or therapeutic procedures. While BenchChem strives to provide accurate protocols, we make no warranties, express or implied, regarding the fitness of this product for every specific experimental setup.

Technical Support: The protocols provided are for reference purposes. Unsure if this reagent suits your experiment?

Need Industrial/Bulk Grade? [Request Custom Synthesis Quote](#)

BenchChem

Our mission is to be the trusted global source of essential and advanced chemicals, empowering scientists and researchers to drive progress in science and industry.

Contact

Address: 3281 E Guasti Rd
Ontario, CA 91761, United States
Phone: (601) 213-4426
Email: info@benchchem.com

[Contact our Ph.D. Support Team for a compatibility check](#)