

# Application Note: 2'-Chloro-biphenyl-3-amine in Medicinal Chemistry & Organic Synthesis

**Author:** BenchChem Technical Support Team. **Date:** May 2026

## Compound of Interest

Compound Name: 2'-Chloro-biphenyl-3-amine

Cat. No.: B1636351

[Get Quote](#)

## Executive Summary

**2'-Chloro-biphenyl-3-amine** (CAS: 579-92-0) is a specialized biaryl building block characterized by a specific meta-amino, ortho'-chloro substitution pattern. Unlike its planar counterparts, the steric bulk of the 2'-chlorine atom forces the biphenyl system into a non-planar, twisted conformation (dihedral angle approx. 50–60°).[1]

This structural torsion makes it a critical tool in Structure-Activity Relationship (SAR) studies, particularly for:

- Kinase Inhibition: Probing hydrophobic pockets in p38 MAPK and B-Raf inhibitors where planar scaffolds fail to achieve specificity.
- Agrochemicals: Serving as a "scaffold hop" analog for succinate dehydrogenase inhibitors (SDHIs) like Boscalid.
- Materials Science: Disrupting pi-stacking in liquid crystal engineering to modulate phase transition temperatures.

## Part 1: Structural Properties & Reactivity Profile

## The Ortho-Chloro Effect

The defining feature of this building block is the steric clash between the 2'-chlorine and the hydrogen atoms at the 2- and 6-positions of the amine-bearing ring.[1] This prevents free rotation around the C1-C1' bond, creating a stable twisted geometry.[1]

Property	2'-Chloro-biphenyl-3-amine	4'-Chloro-biphenyl-3-amine (Comparator)
Geometry	Twisted (Non-planar)	Planar / Free Rotation
Electronic Character	Meta-amine (nucleophilic, inductive withdrawal from ring B)	Meta-amine (nucleophilic)
Solubility	High in DCM, THF, Toluene	Moderate
Key Utility	Selectivity Probe (Steric fit)	General Hydrophobic Spacer

## Reactivity Handles

- Primary Amine (-NH<sub>2</sub>): The 3-position amine is electronically deactivated slightly by the phenyl ring but remains highly nucleophilic for acylation, isocyanate formation, and Pd-catalyzed amination.[1]
- Chlorine Handle (-Cl): The 2'-Cl is relatively inert to standard nucleophilic aromatic substitution ( ) but can be activated for cross-coupling (e.g., Suzuki, Buchwald) using specialized bulky phosphine ligands (e.g., Buchwald's XPhos or RuPhos) if further cyclization is required.

## Part 2: Synthesis of the Building Block

Note: While commercially available, high-purity synthesis is often required for GMP applications to avoid regioisomeric contamination.[1]

### Protocol A: Regioselective Suzuki-Miyaura Coupling

Objective: Synthesize **2'-chloro-biphenyl-3-amine** from 3-aminophenylboronic acid and 1-bromo-2-chlorobenzene.

## Reagents

- Aryl Halide: 1-Bromo-2-chlorobenzene (1.0 equiv)
- Boronic Acid: 3-Aminophenylboronic acid pinacol ester (1.1 equiv)
- Catalyst: Pd(dppf)Cl<sub>2</sub>·DCM (3 mol%)
- Base:  
(3.0 equiv, 2M aqueous solution)[1]
- Solvent: 1,4-Dioxane (degassed)[1]

## Step-by-Step Methodology

- Inerting: Charge a 3-neck round bottom flask with the aryl halide, boronic ester, and Pd catalyst. Evacuate and backfill with Nitrogen ( ) three times.
- Solvation: Add degassed 1,4-Dioxane (0.2 M concentration relative to halide). Stir until solids are dispersed.
- Activation: Add the aqueous solution via syringe under flow.
- Reaction: Heat the mixture to 90°C for 12 hours. Monitor by HPLC/TLC.[1]
  - Checkpoint: The reaction is complete when the aryl halide is <1%. [1]
- Workup: Cool to room temperature. Filter through a Celite pad to remove Pd black.[1] Wash the pad with Ethyl Acetate.[1]

- Extraction: Wash the filtrate with brine ( ). Dry the organic layer over .[\[1\]](#)
- Purification: Concentrate in vacuo. Purify via Flash Column Chromatography (SiO<sub>2</sub>).
  - Eluent: Hexanes:Ethyl Acetate (gradient 90:10 to 70:30).
  - Target: The amine typically elutes after non-polar impurities but before protodeboronated byproducts.[\[1\]](#)

## Part 3: Downstream Functionalization (Application Protocols)

### Protocol B: Synthesis of Diaryl Urea Kinase Inhibitors

Context: Urea linkages are a "privileged scaffold" in kinase inhibitors (e.g., Sorafenib).[\[1\]](#) This protocol couples the building block to an isocyanate to form a p38 MAPK inhibitor motif.[\[1\]](#)

Reaction Scheme:

#### Methodology

- Preparation: Dissolve **2'-chloro-biphenyl-3-amine** (1.0 equiv) in anhydrous Dichloromethane (DCM).
- Addition: Cool the solution to 0°C. Add the target isocyanate (e.g., 3-trifluoromethylphenyl isocyanate) (1.05 equiv) dropwise.
  - Note: If the isocyanate is not available, generate it in situ using Triphosgene and DIPEA. [\[1\]](#)
- Reaction: Allow to warm to Room Temperature (RT) and stir for 4 hours. A white precipitate (the urea) often forms.
- Isolation:

- If precipitate forms: Filter and wash with cold DCM.[1]
- If soluble: Evaporate solvent and recrystallize from Ethanol/Water.[1]

## Protocol C: Buchwald-Hartwig Amination (Secondary Amine Synthesis)

Context: Creating C-N bonds for more complex drug scaffolds.

### Catalyst Selection Logic

Due to the ortho-chloro substituent on the biphenyl ring, the amine is sterically crowded.[1] Standard ligands (BINAP) often fail.

- Recommended Ligand: BrettPhos or RuPhos (Excellent for sterically hindered amines).
- Base: NaOtBu (Sodium tert-butoxide).
- Pre-catalyst: BrettPhos Pd G3.

## Part 4: Workflows and Decision Trees

### Synthesis & Functionalization Workflow

The following diagram illustrates the logical flow from raw materials to final drug candidates using this building block.

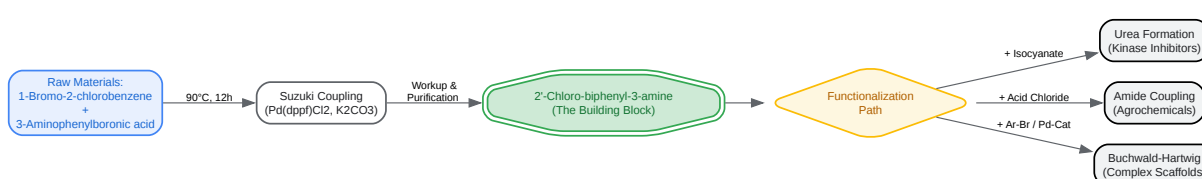

[Click to download full resolution via product page](#)

Caption: Figure 1. Synthesis workflow for generating and utilizing the **2'-Chloro-biphenyl-3-amine** scaffold.

## Catalyst Selection for Downstream Coupling

Choosing the right catalytic system is crucial when using this sterically encumbered amine.[1]

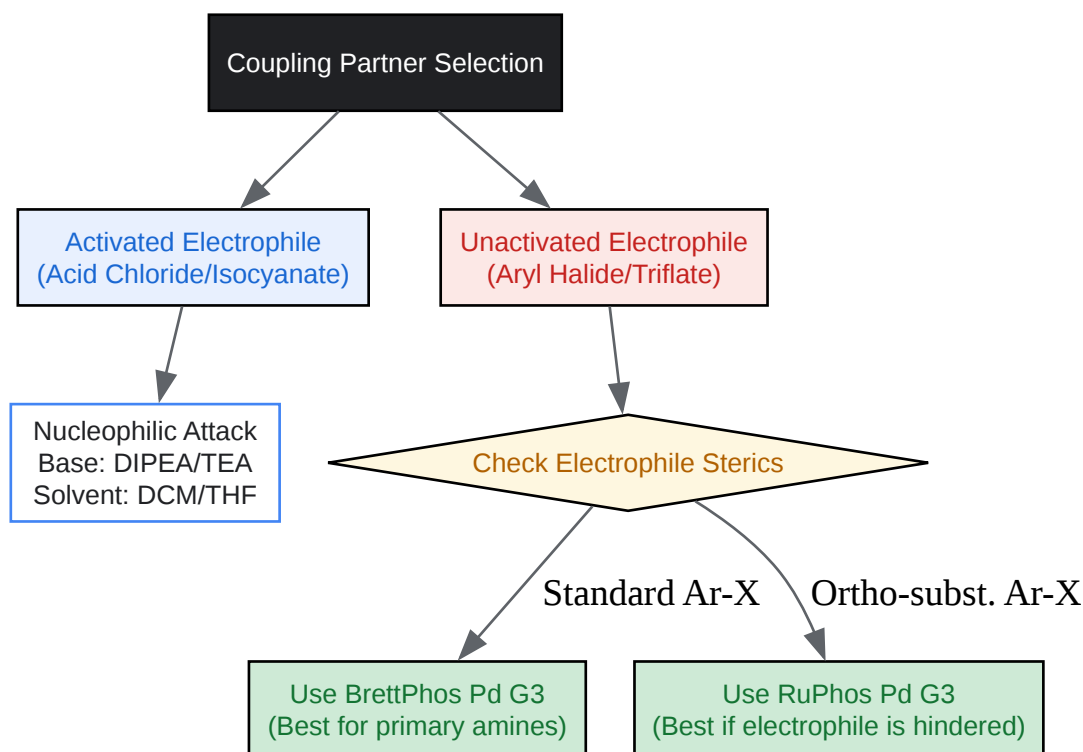

[Click to download full resolution via product page](#)

Caption: Figure 2. Decision tree for selecting reaction conditions based on the electrophilic partner.

## Part 5: Quality Control & Troubleshooting

### Common Impurities[1]

- De-chlorinated Byproduct: (Biphenyl-3-amine).
  - Cause: Oxidative addition of Pd into the Ar-Cl bond during Suzuki coupling (over-reaction).
  - Prevention: Use strictly controlled temperature (do not exceed 90°C) and avoid electron-rich ligands like

which facilitate Ar-Cl activation. Use Pd(dppf) or

- Protodeboronation: (Aniline).
  - Cause: Hydrolysis of the boronic acid before coupling.[1]
  - Prevention: Minimize water content in the solvent system or increase the catalyst loading to outcompete hydrolysis.[1]

## Analytical Specifications

- Appearance: Off-white to pale yellow solid.
- <sup>1</sup>H NMR (CDCl<sub>3</sub>): Distinctive splitting of the biphenyl protons. The 2'-Cl ring protons will appear as a multiplet shifted downfield compared to the amine ring.[1]
- Mass Spectrometry: M+H = 204.05 (approx). Look for the characteristic Chlorine isotope pattern (3:1 ratio of M : M+2).

## References

- Miyaura, N., & Suzuki, A. (1995).[1] Palladium-Catalyzed Cross-Coupling Reactions of Organoboron Compounds. Chemical Reviews.
- Surry, D. S., & Buchwald, S. L. (2008).[1] Biaryl Phosphane Ligands in Palladium-Catalyzed Amination. Angewandte Chemie International Edition.
- Regan, J., et al. (2002).[1] Structure-Activity Relationships of the p38α MAP Kinase Inhibitor BIRB 796. Journal of Medicinal Chemistry. (Demonstrates the utility of twisted biphenyl ureas).
- PubChem Compound Summary. (2023). **2'-Chloro-biphenyl-3-amine**. National Center for Biotechnology Information.[1]

### Need Custom Synthesis?

BenchChem offers custom synthesis for rare earth carbides and specific isotopic labeling.

Email: [info@benchchem.com](mailto:info@benchchem.com) or [Request Quote Online](#).

## Sources

- 1. CN106366002A - Synthesis method of intermediate 4'-chloro-2-aminobiphenyl of boscalid - Google Patents [[patents.google.com](https://patents.google.com)]
- To cite this document: BenchChem. [Application Note: 2'-Chloro-biphenyl-3-amine in Medicinal Chemistry & Organic Synthesis]. BenchChem, [2026]. [Online PDF]. Available at: [<https://www.benchchem.com/product/b1636351/docs#application-note-2-chloro-biphenyl-3-amine-in-medicinal-chemistry-organic-synthesis>]

### Disclaimer & Data Validity:

The information provided in this document is for Research Use Only (RUO) and is strictly not intended for diagnostic or therapeutic procedures. While BenchChem strives to provide accurate protocols, we make no warranties, express or implied, regarding the fitness of this product for every specific experimental setup.

**Technical Support:** The protocols provided are for reference purposes. Unsure if this reagent suits your experiment?

**Need Industrial/Bulk Grade?** [Request Custom Synthesis Quote](#)

## BenchChem

Our mission is to be the trusted global source of essential and advanced chemicals, empowering scientists and researchers to drive progress in science and industry.

### Contact

Address: 3281 E Guasti Rd

Ontario, CA 91761, United States

Phone: (601) 213-4426

Email: [info@benchchem.com](mailto:info@benchchem.com)

Contact our Ph.D. Support Team for a compatibility check