

# Heterocycle Synthesis Support Hub: Substituted Piperidines

**Author:** BenchChem Technical Support Team. **Date:** April 2026

## Compound of Interest

Compound Name: 4-Methyl-1-(3-methylbenzoyl)piperidine

Cat. No.: B1634736

[Get Quote](#)

## Ticket #8492: Resolving Regioisomers in Piperidine Scaffolds

Status: Open | Priority: High | Assigned Specialist: Dr. A. Vance, Senior Application Scientist

### Executive Summary

The synthesis of substituted piperidines is frequently plagued by regio-control failures.<sup>[1]</sup> Whether you are functionalizing an intact ring or building one from acyclic precursors, the competition between steric hindrance and electronic activation often yields intractable mixtures of C2, C3, and C4 isomers.

This guide bypasses standard textbook definitions to address the causality of these failures. We focus on three validated workflows: Directed Lithiation (The Beak-O'Brien Interface), Nucleophilic Addition to Pyridiniums (The Comins Interface), and Cyclization Dynamics.

## Module 1: Functionalizing the Intact Ring (C-H Activation)

The Challenge: You need to install a substituent on a pre-existing piperidine ring. The Trap: Relying on thermodynamic control often leads to mixtures. Kinetic control via Complex Induced Proximity Effect (CIPE) is required for high fidelity.

## Workflow A: C2-Functionalization (The Beak Protocol)

This is the gold standard for installing groups alpha to the nitrogen. The mechanism relies on the coordination of lithium to the carbamate oxygen, directing deprotonation to the equatorial C2 proton.

Standard Operating Procedure (SOP):

- Substrate: N-Boc-piperidine (Do not use N-Benzyl; the benzylic protons are too acidic).
- Solvent: Anhydrous Et<sub>2</sub>O (preferred over THF for C2 selectivity due to tighter aggregation).
- Reagent: s-BuLi / TMEDA (1.2 equiv).
- Conditions:
  - Cool solvent to -78 °C.
  - Add s-BuLi dropwise (keep internal temp < -70 °C).
  - Stir for 10–60 mins.
  - Add electrophile (E<sup>+</sup>).

Critical Control Point: If you observe Boc-migration or ring opening, your temperature spiked. The 2-lithio species is unstable above -50 °C.

## Workflow B: C4-Functionalization (Distal Directing Groups)

Direct C4 functionalization is electronically disfavored. To achieve this, you must override the innate C2 preference using a distal directing group (e.g., C3-aminoquinoline amides) or steric blocking.

Diagram 1: The Lithiation Decision Tree Use this logic flow to select the correct reagent system for your target regioisomer.

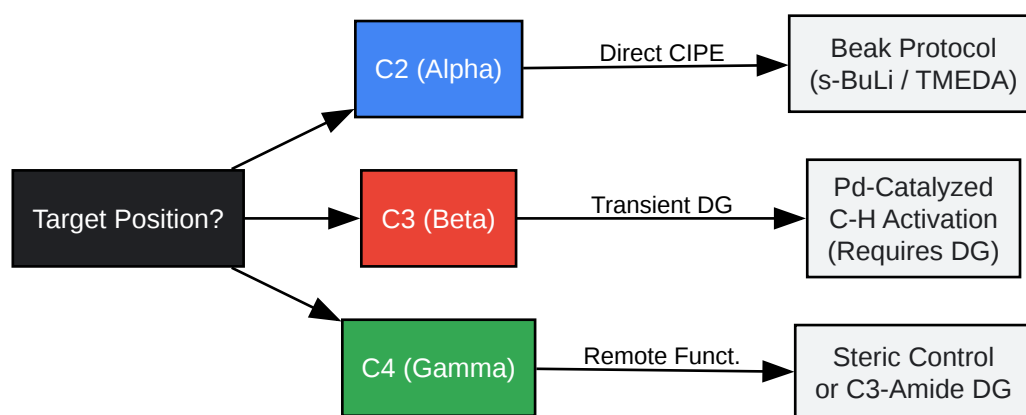

[Click to download full resolution via product page](#)

Figure 1: Decision matrix for regioselective lithiation of N-Boc piperidines.

## Module 2: The Pyridinium Reduction Route (Comins Interface)

The Challenge: Reducing 3-substituted pyridines often yields a racemic mixture of piperidines.

The Solution: Use N-acyl pyridinium salts to activate the ring, followed by nucleophilic attack.

The regioselectivity (1,2- vs 1,4-addition) is dictated by the hardness of the nucleophile and the bulk of the N-substituent.

### Protocol: Regioselective Grignard Addition

To access the C2-substituted dihydropyridine (which reduces to the piperidine):

- Activation: Treat pyridine with phenyl chloroformate (creates the N-phenoxy carbonyl pyridinium salt).
- Nucleophile: Add R-MgBr (Grignard).
  - Note: Grignards prefer 1,2-addition (C2) due to charge control.
  - Contrast: Organocuprates (soft nucleophiles) prefer 1,4-addition (C4).
- Quench: Acidic workup yields the dihydropyridone or piperidone depending on workup severity.

Data Table: Nucleophile Impact on Regioselectivity

Nucleophile Type	Major Regioisomer	Mechanism	Reference
R-MgBr (Hard)	C2 (1,2-addition)	Charge Control	[Comins, 1992]
R <sub>2</sub> CuLi (Soft)	C4 (1,4-addition)	Orbital Control	[Yamaguchi, 1990]
R-ZnBr	Mixed (Substrate dependent)	Intermediate	[Charette, 2002]
NaBH <sub>4</sub>	C2/C6 (1,2-reduction)	Hydride Attack	Standard

### Module 3: Cyclization Dynamics (Baldwin's Rules)

The Challenge: When cyclizing an amino-alkene/alkyne, you form a pyrrolidine (5-membered) instead of a piperidine (6-membered). The Science: 5-exo-trig is kinetically faster than 6-endo-trig.

Troubleshooting Protocol: If your RCM or hydroamination yields the 5-membered ring:

- **Switch Catalyst:** For alkyne substrates, Gold (Au) and Platinum (Pt) catalysts can switch selectivity to 6-endo-dig via specific pi-activation modes.
- **Substrate Bias:** Install a gem-dimethyl group on the tether (Thorpe-Ingold effect) to compress the bond angle, favoring the 6-membered transition state.

Diagram 2: Nucleophilic Attack Vectors on Pyridinium Visualizing the electronic and steric gates for incoming nucleophiles.

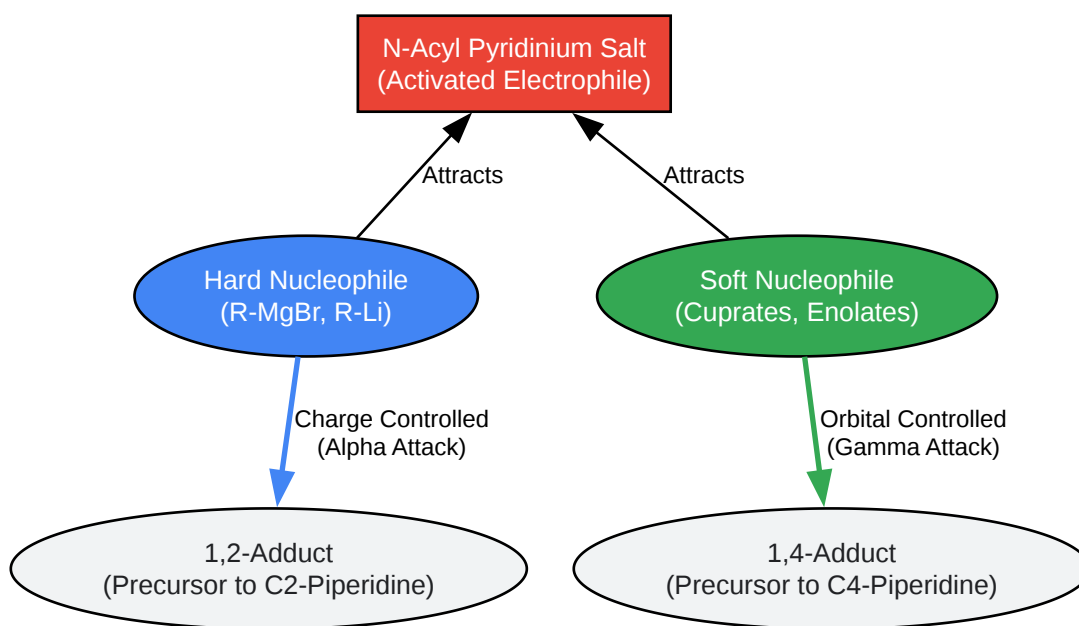

[Click to download full resolution via product page](#)

Figure 2: Regiodivergence in nucleophilic addition to activated pyridinium salts.

## Troubleshooting & FAQs

Q: I performed the Beak lithiation on N-Boc piperidine, but I recovered 50% starting material and 50% product. Why? A: This is likely an aggregation issue. *s*-BuLi can form aggregates that are unreactive.

- Fix: Ensure you are using TMEDA (1.0–1.2 equiv). It breaks down the lithium aggregates to the reactive monomeric species. Also, verify your *s*-BuLi titer; it degrades faster than *n*-BuLi.

Q: My NMR shows "double peaks" for every signal. Is this a mixture of regioisomers? A: Not necessarily. N-Boc piperidines exhibit rotamers due to restricted rotation around the N-C(O) bond.

- Test: Run the NMR at elevated temperature (e.g., 50 °C). If the peaks coalesce into sharp singlets, it is a single regioisomer. If they remain distinct, you have a mixture of isomers.

Q: How do I separate the enantiomers of a C2-substituted piperidine without chiral HPLC? A: Use classical resolution with Tartaric Acid.

- Protocol: Dissolve racemic base in ethanol. Add L-(+)-Tartaric acid. The diastereomeric salt of one enantiomer often crystallizes out preferentially. Recrystallize to constant optical rotation before freeing the base [Benchchem, 2025].[2]

Q: I am trying to arylate at C4 using a Pd-catalyst, but I keep getting C2 arylation. A: C2 is the innate "electronic" preference for Pd insertion in basic media. To hit C4, you must use a Directing Group (DG) at C3 (e.g., picolinamide or aminoquinoline) or use a bulky protecting group on the Nitrogen to sterically shield C2 [Gaunt, 2014].

## References

- Beak, P., & Lee, W. K. (1989). alpha-Lithioamine synthetic equivalents: syntheses of diastereoisomers from Boc derivatives of cyclic amines.[3] *The Journal of Organic Chemistry*. [Link](#)
- Comins, D. L., et al. (1992). Regioselective addition of Grignard reagents to 1-acylpyridinium salts. *The Journal of Organic Chemistry*. [Link](#)
- Gaunt, M. J., et al. (2014). C–H activation of aliphatic amines. *Nature*.[4] [Link](#)
- O'Brien, P., et al. (2006).[3] Reactivity series for s-BuLi/diamine-mediated lithiation of N-Boc pyrrolidine. *Chemical Communications*.[3] [Link](#)
- BenchChem Protocols. (2025). Comparative Analysis of 1-(Piperidin-2-ylmethyl)piperidine Isomers: A Methodological Guide.[Link](#)

### Need Custom Synthesis?

BenchChem offers custom synthesis for rare earth carbides and specific isotopic labeling.

Email: [info@benchchem.com](mailto:info@benchchem.com) or [Request Quote Online](#).

## Sources

- 1. [On the mechanism and selectivity of palladium catalyzed C\(sp<sup>3</sup>\)–H arylation of pyrrolidines and piperidines at unactivated C4 positions: discovery of an improved dimethylamino-quinoline amide directing group \[spiral.imperial.ac.uk\]](#)

- [2. pdf.benchchem.com \[pdf.benchchem.com\]](https://pdf.benchchem.com)
- [3. semanticscholar.org \[semanticscholar.org\]](https://www.semanticscholar.org)
- [4. pdf.benchchem.com \[pdf.benchchem.com\]](https://pdf.benchchem.com)
- To cite this document: BenchChem. [Heterocycle Synthesis Support Hub: Substituted Piperidines]. BenchChem, [2026]. [Online PDF]. Available at: [\[https://www.benchchem.com/product/b1634736/docs#heterocycle-synthesis-support-hub-substituted-piperidines\]](https://www.benchchem.com/product/b1634736/docs#heterocycle-synthesis-support-hub-substituted-piperidines)

---

### Disclaimer & Data Validity:

The information provided in this document is for Research Use Only (RUO) and is strictly not intended for diagnostic or therapeutic procedures. While BenchChem strives to provide accurate protocols, we make no warranties, express or implied, regarding the fitness of this product for every specific experimental setup.

**Technical Support:** The protocols provided are for reference purposes. Unsure if this reagent suits your experiment?

**Need Industrial/Bulk Grade?** [Request Custom Synthesis Quote](#)

## BenchChem

Our mission is to be the trusted global source of essential and advanced chemicals, empowering scientists and researchers to drive progress in science and industry.

### Contact

Address: 3281 E Guasti Rd  
Ontario, CA 91761, United States  
Phone: (601) 213-4426  
Email: [info@benchchem.com](mailto:info@benchchem.com)

[Contact our Ph.D. Support Team for a compatibility check](#)

