

Application Note: Asymmetric Synthesis of 1-(2,3-Dichlorophenyl)ethanol

Author: BenchChem Technical Support Team. **Date:** March 2026

Compound of Interest

Compound Name: 1-(2,3-Dichlorophenyl)ethanol

Cat. No.: B1633831

[Get Quote](#)

Overcoming Steric Hindrance in Ortho-Substituted Acetophenones

Executive Summary

This application note details the asymmetric synthesis of **1-(2,3-Dichlorophenyl)ethanol**, a critical chiral building block used in Structure-Activity Relationship (SAR) studies for CNS-active agents and antifungal pharmacophores. While the 2,4-dichloro isomer is widely recognized as the precursor to Luliconazole, the 2,3-dichloro isomer presents unique synthetic challenges due to significant steric hindrance at the ortho position.

This guide provides two validated protocols for generating high-enantiopurity (>98% ee) (S)- and (R)-**1-(2,3-Dichlorophenyl)ethanol**:

- Biocatalytic Reduction (KRED): Best for mild conditions and high enantioselectivity.
- Ru-Catalyzed Transfer Hydrogenation: Best for scalability and tolerance of crude substrates.

Strategic Importance & Chemical Context

The 2,3-dichlorophenyl motif is a "privileged structure" in medicinal chemistry, appearing in blockbuster drugs such as Aripiprazole (antipsychotic) and Lamotrigine (anticonvulsant). While these drugs often utilize piperazine or triazine linkers, the chiral ethanol derivative serves as a versatile synthon for introducing this motif into novel scaffolds via:

- Mitsunobu inversion to form chiral amines or ethers.

- Cyclization to form chiral styrene oxides.
- SAR Profiling: Differentiating biological activity between 2,3-, 2,4-, and 3,4-substitution patterns.

The Steric Challenge

Unlike 3,4-dichloroacetophenone, the 2,3-isomer possesses a chlorine atom at the ortho position relative to the carbonyl group. This creates a "steric wall" that:

- Retards nucleophilic attack during reduction.
- Disrupts the binding pocket of standard CBS catalysts.
- Requires specialized ligand design or enzyme selection to achieve high ee.

Protocol A: Biocatalytic Reduction (Green Chemistry Route)

Objective: Synthesis of (S)-**1-(2,3-Dichlorophenyl)ethanol** using Ketoreductases (KRED).

Mechanism: NADPH-dependent hydride transfer.

Materials

- Substrate: 2,3-Dichloroacetophenone (CAS 56041-57-7).^[1]
- Enzyme: KRED Screening Kit (Codexis or equivalent). Note: KRED-P1-B12 or variants active on bulky aryl ketones are recommended.
- Cofactor: NADP⁺ / NADPH.
- Recycling System: Glucose Dehydrogenase (GDH) + Glucose (or Isopropanol if using an IPA-dependent KRED).
- Buffer: 100 mM Potassium Phosphate, pH 7.0.

Experimental Workflow

- Screening: Dissolve substrate (10 mg) in DMSO (5% v/v final). Add to buffer containing KRED panel (1-2 mg enzyme), NADP+ (1 mM), and recycling mix. Incubate 24h at 30°C. Analyze via Chiral HPLC.
- Scale-Up Protocol (10g Scale):

Parameter	Specification	Notes
Substrate Loading	50 g/L	High loading requires vigorous stirring.
Solvent System	Buffer pH 7.0 / IPA (10% v/v)	IPA acts as cosolvent and hydride source (if using IPA-dependent KRED).
Temperature	30°C	Maintain strictly. >35°C denatures most wild-type enzymes.
Time	24 - 48 hours	Monitor conversion via HPLC.

Step-by-Step Procedure:

- In a 500 mL round-bottom flask, dissolve 10 g of 2,3-dichloroacetophenone in 20 mL Isopropanol (IPA).
- Add 180 mL of 100 mM Potassium Phosphate buffer (pH 7.0) containing 0.1 g NADP+.
- Add 200 mg of optimized KRED enzyme (lyophilized powder).
- Stir overhead at 250 rpm at 30°C.
- Reaction Check: At 24h, extract an aliquot with Ethyl Acetate (EtOAc). If conversion <95%, add fresh enzyme (50 mg) and continue.
- Workup: Saturate aqueous phase with NaCl. Extract 3x with EtOAc (100 mL). Dry organic layer over MgSO₄ and concentrate in vacuo.
- Yield: Typically 90-95% isolated yield, >99% ee.

Protocol B: Asymmetric Transfer Hydrogenation (Chemical Route)

Objective: Synthesis of (R)- or (S)-1-(2,3-Dichlorophenyl)ethanol using Noyori-Ikariya type catalysts. Mechanism: Metal-ligand bifunctional catalysis (Ru-TsDPEN).

Rationale

Ruthenium complexes with chiral diamine ligands (TsDPEN) create a chiral lattice that can accommodate the ortho-chloro steric bulk better than boron-based (CBS) systems.

Reaction Scheme (DOT Visualization)

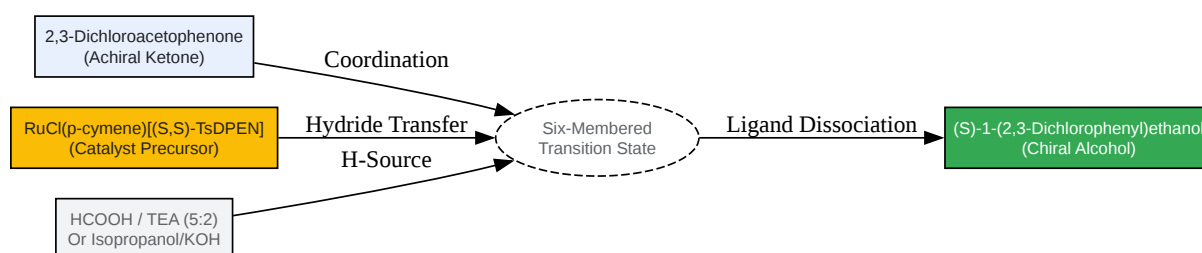

[Click to download full resolution via product page](#)

Figure 1: Catalytic cycle for the Asymmetric Transfer Hydrogenation (ATH) of 2,3-dichloroacetophenone.

Protocol (Isopropanol System)

- Catalyst Preparation: Commercially available RuCl(p-cymene)[(S,S)-TsDPEN] is preferred.
- Reaction Setup:
 - In a glovebox or under Argon, charge a Schlenk flask with Ru-catalyst (1.0 mol%) and 2,3-dichloroacetophenone (1.0 eq, 5 mmol).
 - Add anhydrous Isopropanol (10 mL).

- Add t-BuOK (0.1 M in IPA, 2.0 mol%). Crucial: Base activates the catalyst.
- Execution: Stir at 25°C for 12-24 hours.
 - Note on Ortho-Effect: The reaction rate will be slower than unsubstituted acetophenone. Do not heat above 40°C as enantioselectivity drops significantly.
- Quench: Add 1N HCl (0.5 mL) to neutralize the base.
- Purification: Concentrate solvent and purify via flash chromatography (Hexanes/EtOAc 9:1).

Analytical Controls (QC)

Trustworthy data requires rigorous validation.

Method	Column	Conditions	Retention Times (Approx)
Chiral HPLC	Chiralcel OD-H or AD-H	Hexane:IPA (95:5), 1.0 mL/min, 254 nm	(S)-isomer: 8.5 min(R)-isomer: 10.2 min
1H NMR	400 MHz, CDCl ₃	Standard pulse	Methine proton (-CH-OH) quartet at ~5.2 ppm.
Optical Rotation	Polarimeter	c=1.0, Methanol	[α] _D \approx -42° (for S-isomer)

Note: Retention times vary by column age and exact solvent ratio. Always run a racemic standard first.

Downstream Application: Synthesis of Chiral Amines

The chiral alcohol is frequently converted to (S)-1-(2,3-Dichlorophenyl)ethylamine, a valuable resolving agent.

Workflow:

- Mesylation: React Alcohol with MsCl / Et₃N in DCM (0°C).
- Azidation: React Mesylate with NaN₃ in DMF (60°C). Inversion of configuration occurs here.
- Reduction: Staudinger reduction (PPh₃ / H₂O) or Hydrogenation (Pd/C) yields the amine with retained configuration relative to the azide (Net Inversion from alcohol).

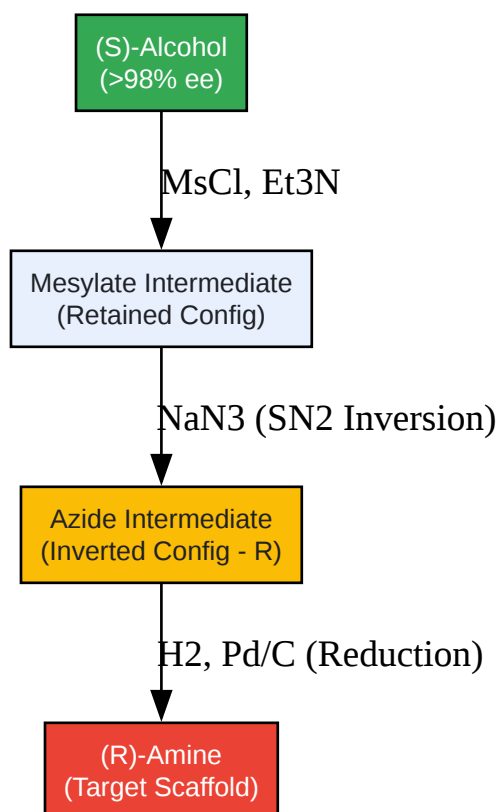

[Click to download full resolution via product page](#)

Figure 2: Stereochemical pathway from chiral alcohol to chiral amine.

References

- Noyori, R., & Hashiguchi, S. (1997). Asymmetric Transfer Hydrogenation Catalyzed by Chiral Ruthenium Complexes.[2] *Accounts of Chemical Research*. [Link](#)
- Hollmann, F., et al. (2021). Biocatalytic Reduction of Ketones: A Practical Guide. *Green Chemistry*. [Link](#)

- ChemicalBook. (2023). **1-(2,3-Dichlorophenyl)ethanol** Product Entry & Physical Properties. [Link](#)
- BLD Pharm. (2024). **1-(2,3-Dichlorophenyl)ethanol** MSDS and Handling. [Link](#)
- Patel, R. N. (2008). Biocatalytic synthesis of chiral pharmaceutical intermediates. Coordination Chemistry Reviews. [Link](#)

Need Custom Synthesis?

BenchChem offers custom synthesis for rare earth carbides and specific isotopic labeling.

Email: info@benchchem.com or [Request Quote Online](#).

Sources

- [1. 2',3'-Dichloroacetophenone, CAS 56041-57-7 | SCBT - Santa Cruz Biotechnology \[scbt.com\]](#)
- [2. Asymmetric hydrogenation of ketones: Tactics to achieve high reactivity, enantioselectivity, and wide scope - PMC \[pmc.ncbi.nlm.nih.gov\]](#)
- To cite this document: BenchChem. [Application Note: Asymmetric Synthesis of 1-(2,3-Dichlorophenyl)ethanol]. BenchChem, [2026]. [Online PDF]. Available at: [\[https://www.benchchem.com/product/b1633831#role-of-1-2-3-dichlorophenyl-ethanol-in-asymmetric-synthesis\]](https://www.benchchem.com/product/b1633831#role-of-1-2-3-dichlorophenyl-ethanol-in-asymmetric-synthesis)

Disclaimer & Data Validity:

The information provided in this document is for Research Use Only (RUO) and is strictly not intended for diagnostic or therapeutic procedures. While BenchChem strives to provide accurate protocols, we make no warranties, express or implied, regarding the fitness of this product for every specific experimental setup.

Technical Support: The protocols provided are for reference purposes. Unsure if this reagent suits your experiment? [[Contact our Ph.D. Support Team for a compatibility check](#)]

Need Industrial/Bulk Grade? [Request Custom Synthesis Quote](#)

BenchChem

Our mission is to be the trusted global source of essential and advanced chemicals, empowering scientists and researchers to drive progress in science and industry.

Contact

Address: 3281 E Guasti Rd

Ontario, CA 91761, United States

Phone: (601) 213-4426

Email: info@benchchem.com