

# A Comprehensive Guide to the Structural Validation of N-(4-bromophenyl)-2-methoxybenzamide

**Author:** BenchChem Technical Support Team. **Date:** April 2026

## Compound of Interest

Compound Name: *N*-(4-bromophenyl)-2-methoxybenzamide

Cat. No.: B1633666

[Get Quote](#)

For Researchers, Scientists, and Drug Development Professionals

## Introduction

**N-(4-bromophenyl)-2-methoxybenzamide** is a substituted aromatic amide of interest in medicinal chemistry and materials science. As with any synthesized compound destined for further investigation, unambiguous confirmation of its molecular structure is a critical first step. This guide outlines a multi-technique approach to structural validation, integrating synthetic methodology with spectroscopic analysis. We will explore the expected outcomes from Nuclear Magnetic Resonance (NMR) spectroscopy, Infrared (IR) spectroscopy, and Mass Spectrometry (MS), providing the logical framework and comparative data necessary to confidently assign the structure.

## Synthesis of N-(4-bromophenyl)-2-methoxybenzamide

The synthesis of **N-(4-bromophenyl)-2-methoxybenzamide** can be efficiently achieved via the Schotten-Baumann reaction. This well-established method involves the acylation of an amine with an acyl chloride in the presence of a base.[1][2][3][4][5]

## Reaction Scheme

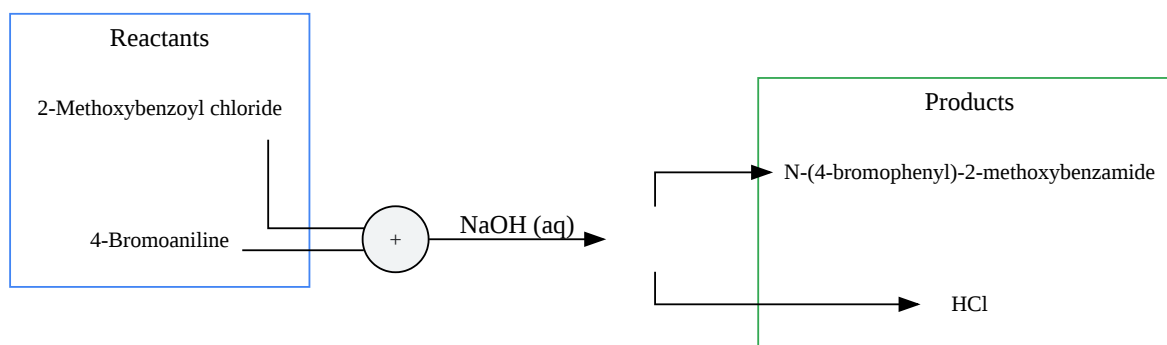

[Click to download full resolution via product page](#)

Caption: Synthesis of **N-(4-bromophenyl)-2-methoxybenzamide**.

## Experimental Protocol:

- **Dissolution of Amine:** In a round-bottom flask, dissolve 4-bromoaniline (1.0 equivalent) in a 10% aqueous solution of sodium hydroxide.
- **Addition of Acyl Chloride:** While vigorously stirring the amine solution at room temperature, slowly add 2-methoxybenzoyl chloride (1.0 equivalent) portion-wise.
- **Reaction:** Continue stirring the biphasic mixture at room temperature for 30-60 minutes. The base neutralizes the hydrochloric acid formed during the reaction, driving the equilibrium towards the amide product.[3]
- **Precipitation and Isolation:** Pour the reaction mixture into a beaker of ice-cold water to precipitate the crude product. Collect the solid by vacuum filtration and wash with cold water to remove any remaining salts.

- Purification: Recrystallize the crude solid from a suitable solvent system, such as ethanol/water, to yield the purified **N-(4-bromophenyl)-2-methoxybenzamide**.

## Structural Validation by Spectroscopic Methods

The following sections detail the expected spectroscopic signatures for **N-(4-bromophenyl)-2-methoxybenzamide**, providing a basis for the validation of the synthesized product's structure.

### Nuclear Magnetic Resonance (NMR) Spectroscopy

NMR spectroscopy is a powerful tool for elucidating the carbon-hydrogen framework of a molecule.<sup>[6]</sup>

The <sup>1</sup>H NMR spectrum is expected to show distinct signals for the aromatic protons, the amide proton, and the methoxy protons.

- Amide Proton (N-H): A broad singlet is anticipated in the downfield region, typically between  $\delta$  8.0 and 10.0 ppm. The chemical shift can be concentration and solvent-dependent.
- Aromatic Protons: Two distinct sets of aromatic signals are expected, corresponding to the two substituted benzene rings.
  - 4-bromophenyl group (para-disubstituted): This will likely appear as a pair of doublets, characteristic of an AA'BB' spin system, in the range of  $\delta$  7.4-7.8 ppm.<sup>[7][8][9][10][11]</sup> The protons ortho to the bromine atom will be at a slightly different chemical shift than the protons ortho to the amide nitrogen.
  - 2-methoxyphenyl group (ortho-disubstituted): This will present a more complex multiplet pattern in the range of  $\delta$  6.9-8.0 ppm, arising from the four adjacent protons with different electronic environments.<sup>[9][12]</sup>
- Methoxy Protons (O-CH<sub>3</sub>): A sharp singlet, integrating to three protons, is expected in the upfield region, typically around  $\delta$  3.8-4.0 ppm.

The proton-decoupled <sup>13</sup>C NMR spectrum will provide information on the unique carbon environments in the molecule.

Carbon Atom	Expected Chemical Shift (ppm)	Rationale
Carbonyl (C=O)	165 - 175	The deshielding effect of the double-bonded oxygen places this carbon significantly downfield.[6]
Aromatic C-Br	115 - 125	The carbon directly attached to the electronegative bromine atom.
Aromatic C-O	155 - 165	The carbon attached to the electron-donating methoxy group will be shifted downfield.
Other Aromatic Carbons	110 - 140	A series of signals corresponding to the remaining aromatic carbons.
Methoxy (O-CH <sub>3</sub> )	55 - 65	The shielded carbon of the methyl group attached to oxygen.

Table 1: Predicted <sup>13</sup>C NMR Chemical Shifts for **N-(4-bromophenyl)-2-methoxybenzamide**.

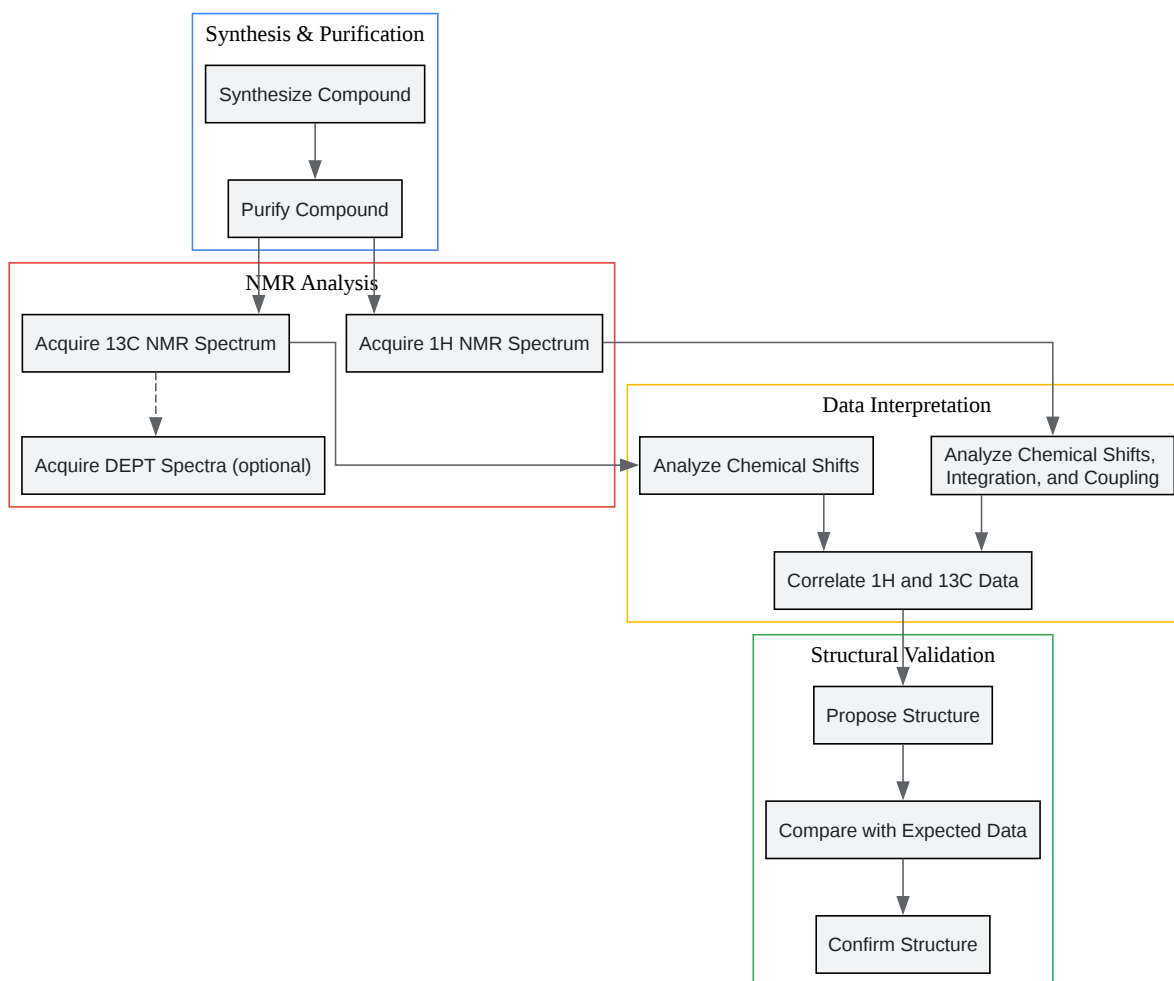

[Click to download full resolution via product page](#)

Caption: Experimental workflow for NMR-based structural validation.

## Infrared (IR) Spectroscopy

IR spectroscopy is used to identify the functional groups present in a molecule based on their characteristic vibrational frequencies.[13][14]

Functional Group	Expected Absorption (cm <sup>-1</sup> )	Intensity/Shape
N-H Stretch (Amide)	3300 - 3500	Medium, sharp (single peak for secondary amide)[15][16]
C-H Stretch (Aromatic)	3000 - 3100	Medium
C-H Stretch (Aliphatic, -OCH <sub>3</sub> )	2850 - 3000	Medium
C=O Stretch (Amide)	1650 - 1700	Strong, sharp[17][18]
C=C Stretch (Aromatic)	1450 - 1600	Medium
C-N Stretch (Amide)	1250 - 1350	Medium
Ar-O-C Stretch (Ether)	1000 - 1300	Strong
C-Br Stretch	515 - 690	Medium to strong[19][20]

Table 2: Key IR Absorption Bands for **N-(4-bromophenyl)-2-methoxybenzamide**.

## Mass Spectrometry (MS)

Mass spectrometry provides information about the molecular weight and fragmentation pattern of a molecule, further confirming its identity.

- **Molecular Ion Peak (M<sup>+</sup>):** The mass spectrum should show a molecular ion peak corresponding to the molecular weight of **N-(4-bromophenyl)-2-methoxybenzamide** (C<sub>14</sub>H<sub>12</sub>BrNO<sub>2</sub>), which is approximately 305.01 g/mol for the <sup>79</sup>Br isotope and 307.01 g/mol for the <sup>81</sup>Br isotope. The presence of bromine will result in a characteristic M+2 peak with nearly equal intensity to the M+ peak.
- **Key Fragmentation Pathways:**

- $\alpha$ -Cleavage: Cleavage of the amide bond is a common fragmentation pathway for benzamides, leading to the formation of a benzoyl cation.[21][22][23] In this case, two primary fragmentation patterns are expected:
  - Loss of the 4-bromophenylamino radical ( $\bullet\text{NHC}_6\text{H}_4\text{Br}$ ) to give the 2-methoxybenzoyl cation.
  - Loss of the 2-methoxybenzoyl radical ( $\bullet\text{COC}_6\text{H}_4\text{OCH}_3$ ) to give the 4-bromophenylaminy cation.
- Loss of Bromine: Fragmentation involving the loss of a bromine radical ( $\bullet\text{Br}$ ) is also possible.

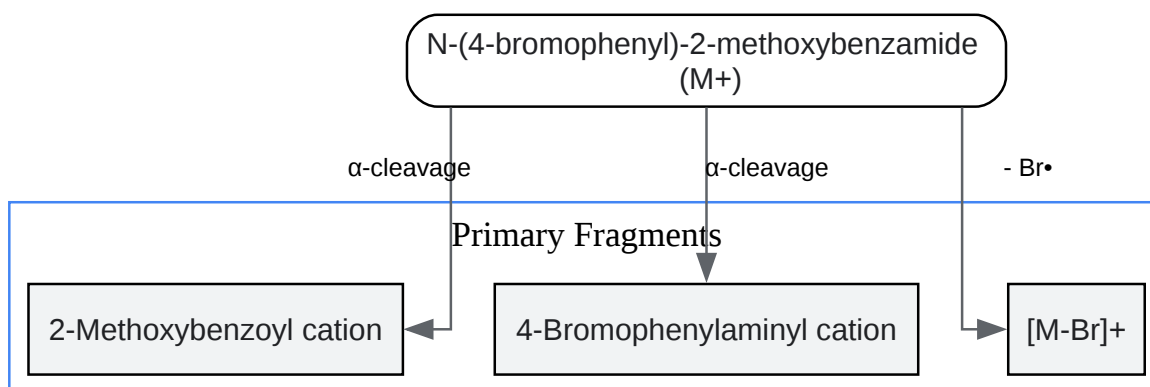

[Click to download full resolution via product page](#)

Caption: Predicted primary fragmentation pathways in mass spectrometry.

## Comparison with Alternative Structures

To ensure the unequivocal assignment of the structure, it is crucial to consider and rule out potential isomers. The primary isomers of concern would be those with different substitution patterns on the aromatic rings, such as "N-(3-bromophenyl)-2-methoxybenzamide" or "N-(4-bromophenyl)-3-methoxybenzamide". The spectroscopic data, particularly the distinct splitting patterns in the  $^1\text{H}$  NMR spectrum for ortho-, meta-, and para-disubstituted rings, will be the most powerful tool for differentiating between these isomers.

## Conclusion

The structural validation of **N-(4-bromophenyl)-2-methoxybenzamide** requires a synergistic approach, combining a reliable synthetic method with comprehensive spectroscopic analysis. By carefully examining the data from <sup>1</sup>H NMR, <sup>13</sup>C NMR, IR, and MS, and comparing it to the expected values and patterns outlined in this guide, researchers can confidently confirm the identity and purity of their synthesized compound. This rigorous validation is the bedrock upon which all subsequent biological or material science investigations are built.

## References

- Schotten–Baumann reaction - Wikipedia. [\[Link\]](#)
- Schotten–Baumann reaction. (2020, August 1). In Wikipedia. [\[Link\]](#)
- Schotten Baumann Reaction. (2019, November 17). BYJU'S. [\[Link\]](#)
- Chemistry Schotten Baumann Reaction. SATHEE. [\[Link\]](#)
- Schotten Baumann Reaction: Definition, Procedure, Mechanism, Uses. Testbook. [\[Link\]](#)
- Mass Spectrometry Interpretation of Benzamide Explain the interpretation.. Filo. [\[Link\]](#)
- Mizrahi, V., Koch, K. R., & Modro, T. A. (1983). V-Substituted benzamides. Nmr spectroscopic study on substituted effects. South African Journal of Chemistry, 36(3), 111-113. [\[Link\]](#)
- IR: alkyl halides. Organic Chemistry at CU Boulder. [\[Link\]](#)
- Harikrishna, K., Balasubramaniam, S., Rakshit, A., & Singh Aidhen, I. (2015). Some interesting <sup>1</sup>H NMR features of ortho substituted N-methoxy-N-methyl benzamides. Indian Journal of Chemistry - Section B, 54B(1), 77-83. [\[Link\]](#)
- Abraham, R. J., Byrne, J. J., Griffiths, L., & Perez, M. (2005). Heteronuclear <sup>13</sup>C, <sup>15</sup>N and <sup>17</sup>O NMR cross-correlations of 4-substituted benzamide derivatives. Magnetic Resonance in Chemistry, 43(8), 611-616. [\[Link\]](#)

- Levy, G. C., & Nelson, G. L. (1972). Carbon-13 NMR study of aliphatic amides and oximes. Spin-lattice relaxation times and fast internal motions. *Journal of the American Chemical Society*, 94(14), 4897-4901. [\[Link\]](#)
- Abraham, R. J., & Mobli, M. (2014). <sup>1</sup>H NMR Spectra Part 31: <sup>1</sup>H Chemical Shifts of Amides in DMSO Solvent. *Magnetic Resonance in Chemistry*, 52(10), 577-587. [\[Link\]](#)
- Video: NMR Spectroscopy of Benzene Derivatives. (2025, May 22). JoVE. [\[Link\]](#)
- NMR Spectroscopy of Benzene Derivatives. Moodle. [\[Link\]](#)
- Peruncheralathan, S., Tantry, S. J., & Kumar, M. S. (2021). Synthesis and Single Crystal Structures of N-Substituted Benzamides and Their Chemoselective Selenation/Reduction Derivatives. *Molecules*, 26(8), 2296. [\[Link\]](#)
- Li, Y., et al. (2021). Fe-mediated synthesis of N-aryl amides from nitroarenes and acyl chlorides. *RSC Advances*, 11(26), 15933-15937. [\[Link\]](#)
- Infrared (IR) Spectroscopy: A Quick Primer On Interpreting Spectra. (2016, November 23). Master Organic Chemistry. [\[Link\]](#)
- 6.3: IR Spectrum and Characteristic Absorption Bands. (2021, December 15). In Chemistry LibreTexts. [\[Link\]](#)
- 6.6: <sup>1</sup>H NMR Spectra and Interpretation (Part I). (2021, December 15). In Chemistry LibreTexts. [\[Link\]](#)
- Common HNMR Patterns. Organic Chemistry Tutor. [\[Link\]](#)
- Infrared (IR) Spectroscopy Practice Problems. (2025, September 20). Chemistry Steps. [\[Link\]](#)
- Advanced Organic Chemistry: H-1 NMR spectrum of 1,4-dimethylbenzene. Doc Brown. [\[Link\]](#)
- Ahmed, A. A., et al. (2018). Fragmentation pattern of amides by EI and HRESI: study of protonation sites using DFT-3LYP data. *RSC Advances*, 8(40), 22448-22456. [\[Link\]](#)

- 6 - IR - spectroscopy. [[Link](#)]
- IR Spectroscopy - Basic Introduction. (2020, July 29). [Video]. YouTube. [[Link](#)]
- Benzamide - Optional[<sup>13</sup>C NMR] - Chemical Shifts. SpectraBase. [[Link](#)]
- Benzamide-simplified mass spectrum[1]. ResearchGate. [[Link](#)]
- Assigning the <sup>1</sup>H-NMR Signals of Aromatic Ring <sup>1</sup>H-atoms. [[Link](#)]
- Short Summary of <sup>1</sup>H-NMR Interpretation. [[Link](#)]
- Kaltsoyannis, N., & E. S. E. van der Graaf. (1993). Dissociation of proton-bound complexes and proton affinity of benzamides. *Journal of the American Society for Mass Spectrometry*, 4(11), 884-892. [[Link](#)]
- Mass Spectrometry - Fragmentation Patterns. (2023, August 29). In Chemistry LibreTexts. [[Link](#)]
- NMR magnetically equivalent protons for a 1,4-disubstituted benzene ring. (2020, January 1). Chemistry Stack Exchange. [[Link](#)]
- IR Chart. [[Link](#)]
- IR Spectrum | Table of IR Spectroscopy Values. ChemTalk. [[Link](#)]
- Arenecarboxylic acid or benzamide synthesis by carboxylation or C-C coupling. Organic Chemistry Portal. [[Link](#)]
- Synthesis of N-substituted benzamides-thiobenzamides from N-aryl-N 0 -benzoylthioureas a. ResearchGate. [[Link](#)]
- The features of IR spectrum. [[Link](#)]
- 11.5: Infrared Spectra of Some Common Functional Groups. (2020, May 30). In Chemistry LibreTexts. [[Link](#)]

- A New Approach for the Synthesis of N-Arylamides Starting from Benzonitriles. (2021, November 14). *Molecules*, 26(22), 6907. [[Link](#)]
- Table of Characteristic IR Absorptions. [[Link](#)]

### Need Custom Synthesis?

BenchChem offers custom synthesis for rare earth carbides and specific isotopic labeling.

Email: [info@benchchem.com](mailto:info@benchchem.com) or [Request Quote Online](#).

## Sources

- 1. Schotten–Baumann reaction - Wikipedia [[en.wikipedia.org](https://en.wikipedia.org)]
- 2. [lscollge.ac.in](https://lscollge.ac.in) [[lscollge.ac.in](https://lscollge.ac.in)]
- 3. [byjus.com](https://byjus.com) [[byjus.com](https://byjus.com)]
- 4. SATHEE: Chemistry Schotten Baumann Reaction [[sathee.iitk.ac.in](https://sathee.iitk.ac.in)]
- 5. [testbook.com](https://testbook.com) [[testbook.com](https://testbook.com)]
- 6. [pdf.benchchem.com](https://pdf.benchchem.com) [[pdf.benchchem.com](https://pdf.benchchem.com)]
- 7. Video: NMR Spectroscopy of Benzene Derivatives [[jove.com](https://jove.com)]
- 8. [moodle.tau.ac.il](https://moodle.tau.ac.il) [[moodle.tau.ac.il](https://moodle.tau.ac.il)]
- 9. [organicchemistrytutor.com](https://organicchemistrytutor.com) [[organicchemistrytutor.com](https://organicchemistrytutor.com)]
- 10. C<sub>8</sub>H<sub>10</sub> 1,4-dimethylbenzene low high resolution H-1 proton nmr spectrum of analysis interpretation of chemical shifts ppm spin spin line splitting H1 p-xylene 1-H nmr doc brown's advanced organic chemistry revision notes [[docbrown.info](https://docbrown.info)]
- 11. [chemistry.stackexchange.com](https://chemistry.stackexchange.com) [[chemistry.stackexchange.com](https://chemistry.stackexchange.com)]
- 12. [chem.libretexts.org](https://chem.libretexts.org) [[chem.libretexts.org](https://chem.libretexts.org)]
- 13. Infrared (IR) Spectroscopy Practice Problems [[chemistrysteps.com](https://chemistrysteps.com)]
- 14. [uanlch.vscht.cz](https://uanlch.vscht.cz) [[uanlch.vscht.cz](https://uanlch.vscht.cz)]
- 15. [masterorganicchemistry.com](https://masterorganicchemistry.com) [[masterorganicchemistry.com](https://masterorganicchemistry.com)]
- 16. [m.youtube.com](https://m.youtube.com) [[m.youtube.com](https://m.youtube.com)]
- 17. [chem.libretexts.org](https://chem.libretexts.org) [[chem.libretexts.org](https://chem.libretexts.org)]

- [18. chem.pg.edu.pl \[chem.pg.edu.pl\]](#)
- [19. orgchemboulder.com \[orgchemboulder.com\]](#)
- [20. orgchemboulder.com \[orgchemboulder.com\]](#)
- [21. Mass Spectrometry Interpretation of Benzamide Explain the interpretation.. \[askfilo.com\]](#)
- [22. Fragmentation pattern of amides by EI and HRESI: study of protonation sites using DFT-3LYP data - RSC Advances \(RSC Publishing\) DOI:10.1039/C7RA00408G \[pubs.rsc.org\]](#)
- [23. researchgate.net \[researchgate.net\]](#)
- To cite this document: BenchChem. [A Comprehensive Guide to the Structural Validation of N-(4-bromophenyl)-2-methoxybenzamide]. BenchChem, [2026]. [Online PDF]. Available at: [<https://www.benchchem.com/product/b1633666/docs#a-comprehensive-guide-to-the-structural-validation-of-n-4-bromophenyl-2-methoxybenzamide>]

---

#### Disclaimer & Data Validity:

The information provided in this document is for Research Use Only (RUO) and is strictly not intended for diagnostic or therapeutic procedures. While BenchChem strives to provide accurate protocols, we make no warranties, express or implied, regarding the fitness of this product for every specific experimental setup.

**Technical Support:** The protocols provided are for reference purposes. Unsure if this reagent suits your experiment?

**Need Industrial/Bulk Grade?** [Request Custom Synthesis Quote](#)

## BenchChem

Our mission is to be the trusted global source of essential and advanced chemicals, empowering scientists and researchers to drive progress in science and industry.

#### Contact

Address: 3281 E Guasti Rd

Ontario, CA 91761, United States

Phone: (601) 213-4426

Email: [info@benchchem.com](mailto:info@benchchem.com)

Contact our Ph.D. Support Team for a compatibility check