

An In-depth Technical Guide to the Structure of 2-Cyclobutylethanol

Author: BenchChem Technical Support Team. **Date:** May 2026

Compound of Interest

Compound Name: 2-Cyclobutylethanol

CAS No.: 4415-74-1

Cat. No.: B1632531

[Get Quote](#)

Abstract: This technical guide provides a comprehensive analysis of the molecular structure of **2-cyclobutylethanol** (CAS No: 4415-74-1). It is intended for researchers, scientists, and professionals in drug development who require a deep understanding of this compound's physicochemical properties. The guide covers its chemical identity, molecular architecture, conformational analysis, and detailed spectroscopic characterization. Furthermore, it presents a validated synthetic protocol and discusses the key physicochemical properties, grounding all claims in authoritative references.

Chemical Identity and Nomenclature

2-Cyclobutylethanol is a primary alcohol featuring a cyclobutane ring attached to an ethanol backbone.^{[1][2]} Its fundamental identifiers are crucial for regulatory and experimental documentation.

Identifier	Value	Source
IUPAC Name	2-cyclobutylethanol	PubChem[3]
Synonyms	Cyclobutaneethanol, 2-cyclobutylethan-1-ol	CymitQuimica[2][4]
CAS Number	4415-74-1	BenchChem[1]
Molecular Formula	C ₆ H ₁₂ O	PubChem[3]
Molecular Weight	100.16 g/mol	BenchChem[1]
InChI Key	KUARIPXRZDVUJO-UHFFFAOYSA-N	CymitQuimica[4]

Molecular Structure and Conformational Analysis

The structure of **2-cyclobutylethanol** is a unique combination of a strained four-membered ring and a flexible hydroxyethyl side chain.[1] This arrangement dictates its reactivity and physical properties.

- Cyclobutane Ring:** The cyclobutane moiety is not planar. It adopts a puckered or "butterfly" conformation to alleviate some of the inherent angle strain (ideal sp³ angle is 109.5°, whereas a planar square would have 90° angles). This puckering is a dynamic equilibrium between two equivalent conformations. The strain within this ring is a key factor in its chemical behavior.[2]
- Ethyl Side-Chain:** The two-carbon chain links the reactive primary hydroxyl group to the sterically bulky cyclobutyl group. Free rotation exists around the C-C single bonds, allowing the molecule to adopt various conformations. The most stable conformers will seek to minimize steric hindrance between the cyclobutane ring and the terminal hydroxyl group.
- Hydroxyl Group:** The primary alcohol functional group is the main site of reactivity, capable of undergoing oxidation, esterification, and etherification. It also allows the molecule to act as both a hydrogen bond donor and acceptor, influencing its boiling point and solubility.

Caption: Ball-and-stick model of **2-cyclobutylethanol**.

Spectroscopic Characterization

The elucidation of **2-cyclobutylethanol**'s structure is definitively achieved through a combination of spectroscopic techniques. Each method provides a unique piece of the structural puzzle.

^1H NMR Spectroscopy (Predicted)

In a ^1H NMR spectrum, the chemical environment of each proton determines its resonance frequency (chemical shift).

- -OH (Hydroxyl Proton): A broad singlet, typically in the range of 1-5 ppm. Its position is variable and depends on concentration and solvent due to hydrogen bonding.
- -CH₂-O- (Methylene protons alpha to oxygen): A triplet around 3.6 ppm. These protons are deshielded by the adjacent electronegative oxygen atom. The signal is split into a triplet by the two neighboring protons on the adjacent methylene group.
- -CH₂- (Methylene protons beta to oxygen): A multiplet around 1.5-1.7 ppm. These protons are coupled to both the alpha-methylene protons and the methine proton on the cyclobutane ring.
- Cyclobutane Protons: A complex series of multiplets between 1.7 and 2.1 ppm. The puckered nature of the ring and the different environments of the axial and equatorial protons lead to complex splitting patterns. The methine proton (CH attached to the side chain) will be the most downfield of this group.

^{13}C NMR Spectroscopy (Predicted)

The ^{13}C NMR spectrum provides information on the different carbon environments.

- -CH₂-O-: ~60-65 ppm. Deshielded by the oxygen atom.
- -CH₂-: ~35-40 ppm.
- CH (Cyclobutane methine): ~35-40 ppm.

- CH₂ (Cyclobutane methylene): ~20-25 ppm. Due to symmetry, only two distinct signals are expected for the cyclobutane ring carbons in a decoupled spectrum.

Infrared (IR) Spectroscopy

IR spectroscopy identifies the functional groups present based on their vibrational frequencies.

- O-H Stretch: A strong, broad absorption band in the region of 3200-3600 cm⁻¹. The broadening is a characteristic result of intermolecular hydrogen bonding.
- C-H Stretch (sp³): Sharp peaks just below 3000 cm⁻¹ (typically 2850-2960 cm⁻¹).
- C-O Stretch: A distinct, strong absorption in the 1050-1150 cm⁻¹ region, characteristic of a primary alcohol.

Mass Spectrometry (MS)

Mass spectrometry provides information about the molecular weight and fragmentation pattern.

- Molecular Ion (M⁺): A peak at m/z = 100, corresponding to the molecular weight of C₆H₁₂O.
- Key Fragments:
 - m/z = 82: Loss of water (H₂O) from the molecular ion.
 - m/z = 71: Loss of the ethyl group (-CH₂CH₃).
 - m/z = 57: Represents the cyclobutyl cation.
 - m/z = 31: A common fragment for primary alcohols, corresponding to [CH₂OH]⁺.

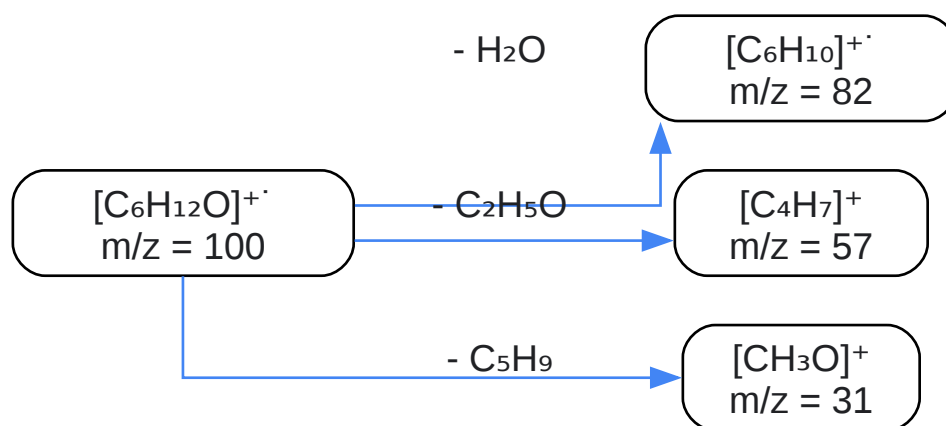

[Click to download full resolution via product page](#)

Caption: Key fragmentation pathways for **2-cyclobutylethanol** in MS.

Synthesis Protocol: Reduction of Cyclobutylacetic Acid

A reliable method for synthesizing **2-cyclobutylethanol** is the reduction of cyclobutylacetic acid using a strong reducing agent like Lithium Aluminum Hydride (LAH).

Expertise & Rationale: LAH is chosen over weaker reducing agents like sodium borohydride ($NaBH_4$) because $NaBH_4$ is generally not reactive enough to reduce carboxylic acids. The reaction must be performed under strictly anhydrous (water-free) conditions as LAH reacts violently with water. Diethyl ether or Tetrahydrofuran (THF) are common solvents as they are anhydrous and can dissolve the reactants. The final step involving an acidic workup is crucial to protonate the intermediate alkoxide and neutralize any remaining LAH.

Step-by-Step Methodology

- Setup: A flame-dried, three-necked round-bottom flask is equipped with a magnetic stirrer, a reflux condenser, and a nitrogen inlet.
- Reagent Addition: Anhydrous diethyl ether is added to the flask, followed by the slow, portion-wise addition of Lithium Aluminum Hydride (LAH) powder at 0 °C (ice bath).
- Substrate Addition: Cyclobutylacetic acid, dissolved in anhydrous diethyl ether, is added dropwise to the stirred LAH suspension. The rate of addition is controlled to maintain a

gentle reflux.

- **Reaction:** After the addition is complete, the mixture is brought to room temperature and stirred for several hours, or until Thin Layer Chromatography (TLC) indicates the complete consumption of the starting material.
- **Quenching (Self-Validation):** The reaction is carefully quenched by the sequential, dropwise addition of water, followed by 15% aqueous sodium hydroxide, and then more water (Fieser workup). This procedure is critical for safety and results in a granular precipitate of aluminum salts that is easily filtered.
- **Extraction & Purification:** The organic layer is decanted and the solid residue is washed with diethyl ether. The combined organic extracts are dried over anhydrous magnesium sulfate, filtered, and the solvent is removed under reduced pressure.
- **Final Purification:** The crude product is purified by fractional distillation or column chromatography to yield pure **2-cyclobutylethanol**. The purity is confirmed by NMR and GC-MS analysis.

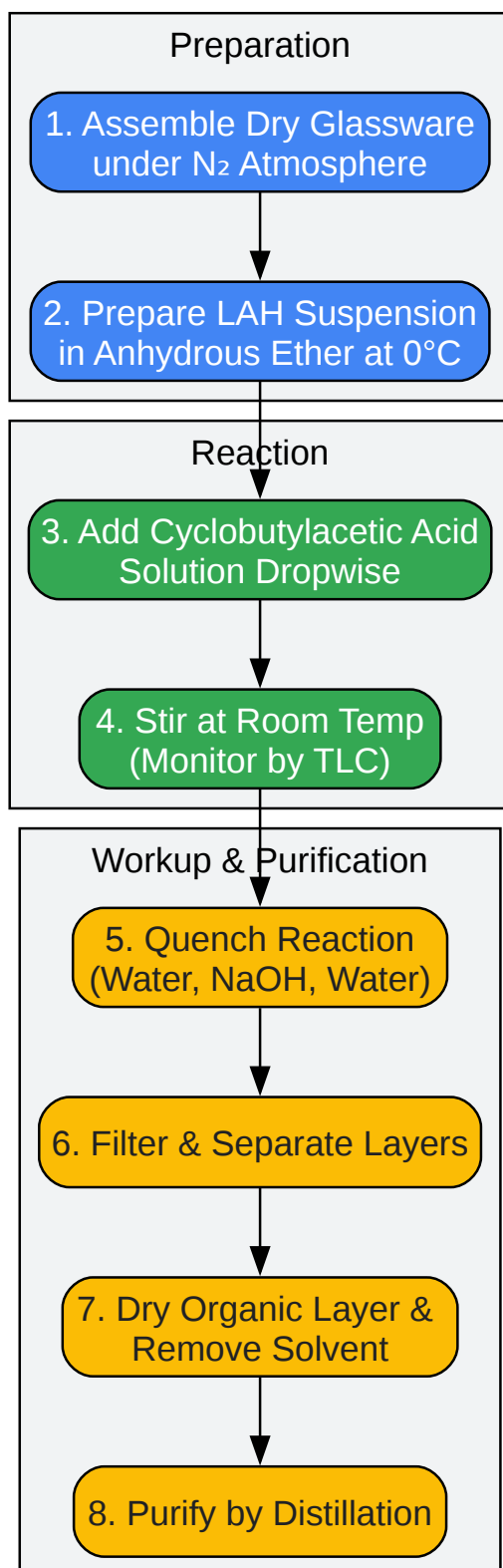

[Click to download full resolution via product page](#)

Caption: Experimental workflow for the synthesis of **2-cyclobutylethanol**.

Physicochemical Properties

The physical properties of **2-cyclobutylethanol** are a direct consequence of its molecular structure.

Property	Value	Notes
Appearance	Colorless Liquid	Typical for small alcohols[4].
Boiling Point	~160-165 °C	Higher than non-polar alkanes of similar mass due to hydrogen bonding.
Solubility	Moderately soluble in water	The hydroxyl group allows for hydrogen bonding with water, while the cyclobutyl group is hydrophobic.
Purity	Typically >95-97%	Commercially available purity[4].

Safety and Handling

2-Cyclobutylethanol is classified as a flammable liquid and can cause skin and eye irritation. [3] It may also cause respiratory irritation.[3] Standard laboratory safety protocols should be followed:

- Handle in a well-ventilated fume hood.
- Wear appropriate personal protective equipment (PPE), including safety goggles, gloves, and a lab coat.
- Store in a cool, dry, well-ventilated area away from ignition sources.

Conclusion

The structure of **2-cyclobutylethanol**, defined by its puckered cyclobutane ring and primary alcohol function, gives rise to a distinct set of spectroscopic signatures and physicochemical properties. Its role as a versatile building block in organic synthesis is facilitated by the

reactivity of the hydroxyl group, while the cyclobutyl moiety offers a way to introduce conformational constraint and modulate lipophilicity in larger molecules. A thorough understanding of its structural characteristics, as detailed in this guide, is essential for its effective application in research and development.

References

- National Center for Biotechnology Information (2024). PubChem Compound Summary for CID 21441185, Cyclobutaneethanol. Retrieved from [[Link](#)].

Need Custom Synthesis?

BenchChem offers custom synthesis for rare earth carbides and specific isotopic labeling.

Email: info@benchchem.com or [Request Quote Online](#).

Sources

- 1. 2-Cyclobutylethanol|CAS 4415-74-1|Supplier [[benchchem.com](https://www.benchchem.com)]
- 2. CAS 4415-74-1: Cyclobutaneethanol | [CymitQuimica \[cymitquimica.com\]](https://www.cymitquimica.com)
- 3. Cyclobutaneethanol | C6H12O | CID 21441185 - PubChem [pubchem.ncbi.nlm.nih.gov]
- 4. 2-Cyclobutylethanol | [CymitQuimica \[cymitquimica.com\]](https://www.cymitquimica.com)
- To cite this document: BenchChem. [An In-depth Technical Guide to the Structure of 2-Cyclobutylethanol]. BenchChem, [2026]. [Online PDF]. Available at: [<https://www.benchchem.com/product/b1632531/docs#an-in-depth-technical-guide-to-the-structure-of-2-cyclobutylethanol>]

Disclaimer & Data Validity:

The information provided in this document is for Research Use Only (RUO) and is strictly not intended for diagnostic or therapeutic procedures. While BenchChem strives to provide accurate protocols, we make no warranties, express or implied, regarding the fitness of this product for every specific experimental setup.

Technical Support: The protocols provided are for reference purposes. Unsure if this reagent suits your experiment?

Need Industrial/Bulk Grade? [Request Custom Synthesis Quote](#)

BenchChem

Our mission is to be the trusted global source of essential and advanced chemicals, empowering scientists and researchers to drive progress in science and industry.

Contact

Address: 3281 E Guasti Rd
Ontario, CA 91761, United States
Phone: (601) 213-4426
Email: info@benchchem.com

[Contact our Ph.D. Support Team for a compatibility check](#)