

Technical Guide: Spectral Interpretation of (S)-2-(3-Bromophenyl)piperidine

Author: BenchChem Technical Support Team. **Date:** May 2026

Compound of Interest

Compound Name: (S)-2-(3-Bromophenyl)piperidine

Cat. No.: B1631101

[Get Quote](#)

Executive Summary

(S)-2-(3-Bromophenyl)piperidine (CAS: 144235-97-6) is a critical chiral building block, most notably serving as the core scaffold for Niraparib (Zejula), a poly(ADP-ribose) polymerase (PARP) inhibitor used in ovarian cancer therapy. Its structural integrity—specifically the meta-substitution of the bromine and the (S)-configuration at the C2 position—is paramount for downstream pharmacological efficacy.

This guide provides a comparative spectral analysis, distinguishing this compound from its regioisomers (4-bromo analogs) and its salt forms, offering researchers a self-validating protocol for structural confirmation.

Structural Analysis & Numbering Strategy

To ensure accurate assignment, we utilize a standardized numbering scheme. The molecule consists of a piperidine ring substituted at the C2 position by a 3-bromophenyl group.

Visualization: Structural Connectivity & Correlations

The following diagram outlines the atom numbering and key Through-Bond (COSY/HMBC) and Through-Space (NOESY) correlations required for confirmation.

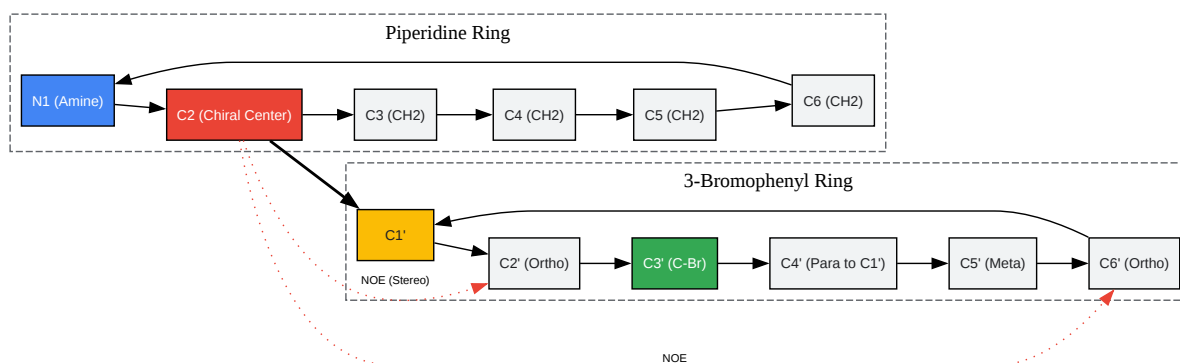

[Click to download full resolution via product page](#)

Caption: Atom connectivity and critical NOE interactions for confirming the C2-Aryl bond.

Comparative NMR Data Analysis

The following data compares the Free Base form (CDCl_3) against the Hydrochloride Salt (DMSO-d_6). Note that salt formation significantly deshields the protons adjacent to the nitrogen (H2 and H6).

Table 1: ^1H NMR Chemical Shift Assignments (400 MHz)

Position	Proton	Free Base (CDCl ₃) δ (ppm)	HCl Salt (DMSO-d ₆) δ (ppm)	Multiplicity & Coupling (in Hz)	Diagnostic Feature
C2	H2	3.62	4.25 - 4.35	dd ()	Key Chiral Handle. Large shift upon protonation.
C6	H6a, H6b	3.15, 2.75	3.25 - 3.40	m (broadened in salt)	Deshielded by N-protonation.
C3	H3a, H3b	1.85, 1.50	1.90 - 2.10	m	Diastereotopic protons.
C4/C5	H4/H5	1.40 - 1.70	1.50 - 1.80	m	Overlapping multiplets.
N1	NH	~1.8 (broad)	9.20 - 9.60	br s (exchanges D ₂ O)	Ammonium protons in salt form are distinct.
C2'	Ar-H2'	7.55	7.75	t ()	Diagnostic: Isolated singlet-like triplet (between C1' and C3'-Br).
C4'	Ar-H4'	7.38	7.55	ddd ()	Deshielded by ortho-Br.
C5'	Ar-H5'	7.18	7.35	t ()	Pseudo-triplet.

C6'	Ar-H6'	7.28	7.45	dt ()	Overlaps often with solvent/other aromatics.
-----	--------	------	------	--------	--

Table 2: ¹³C NMR Chemical Shift Assignments (100 MHz)

Carbon	Free Base (CDCl ₃) δ (ppm)	HCl Salt (DMSO-d ₆) δ (ppm)	Assignment Logic
C2	62.5	58.4	Benzylic & Amine-adjacent.
C6	47.8	44.5	Amine-adjacent methylene.
C3	35.2	32.1	Beta to amine.
C4	25.8	22.8	Gamma to amine.
C5	26.1	23.1	Gamma to amine.
C1'	147.5	142.0	Quaternary (Ipso).
C3'	122.6	122.0	C-Br Quaternary. Distinctive upfield shift for aromatic C-Br.
Ar-CH	129-131	127-132	Remaining aromatic carbons.

Critical Differentiation: Regioisomers & Enantiomers

A common pitfall in synthesizing Niraparib intermediates is the contamination with the 4-bromo isomer or racemization.

Workflow: Distinguishing 3-Bromo vs. 4-Bromo

The splitting pattern in the aromatic region is the definitive test.

- 3-Bromo (Target): Asymmetric pattern.^[1] Look for the isolated H2' (singlet-like) at ~7.55 ppm and the H5' triplet.
- 4-Bromo (Impurity): Symmetric AA'BB' system. Two distinct doublets (roofing effect) integrating to 2H each.

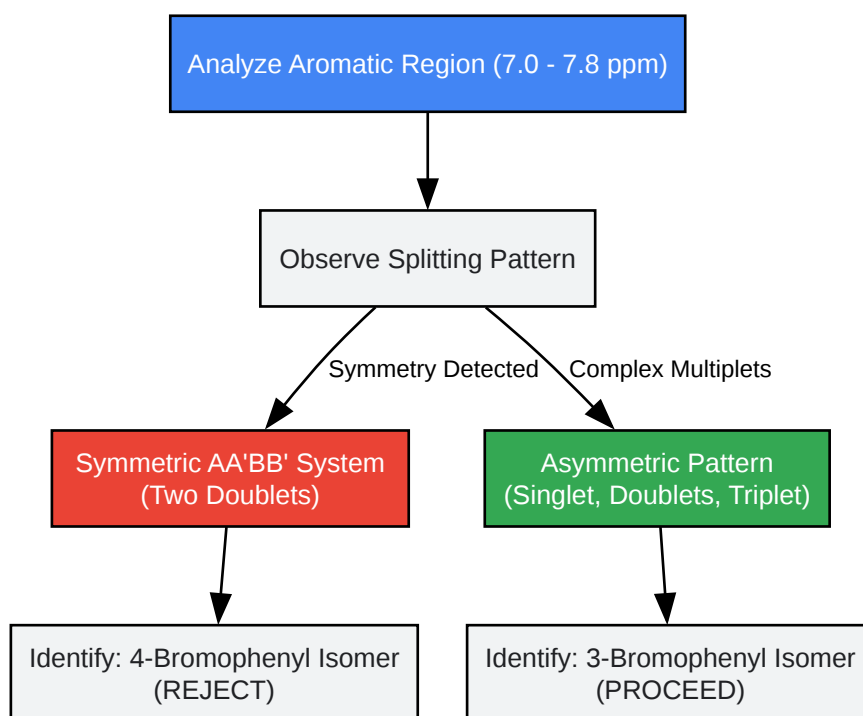

[Click to download full resolution via product page](#)

Caption: Decision logic for regioisomer identification based on aromatic splitting.

Chiral Purity Determination

Standard NMR cannot distinguish (S) from (R) enantiomers.

- Protocol: Derivatization with (R)-(-)-Mosher's Acid Chloride.
- Observation: The diastereomeric amides formed will show distinct chemical shifts for the H2 methine proton.
- Performance:

ppm is typically observed, allowing integration of diastereomers to calculate Enantiomeric Excess (ee).

Experimental Protocols

Protocol A: NMR Sample Preparation (Free Base)

- Isolation: Ensure the sample is fully partitioned into an organic solvent (DCM/EtOAc) and washed with NaHCO_3 to ensure the free base form. Evaporate to dryness.
- Solvent: Dissolve 10-15 mg of oil/solid in 0.6 mL CDCl_3 (neutralized with basic alumina if acid sensitivity is suspected).
- Acquisition:
 - Relaxation Delay (d1): 2.0 seconds (ensure quantitative integration of aromatics).
 - Scans (ns): 16 (1H), 512+ (13C).

Protocol B: Salt Formation Verification

- Dissolve 20 mg of free base in EtOH.
- Add 1.1 eq of HCl (in ether or dioxane).
- Precipitate with Et_2O , filter, and dry.
- Solvent: Dissolve in DMSO-d_6 .
- Check: Look for the disappearance of the sharp amine signal and appearance of broad ammonium peaks at >9.0 ppm.

References

- Niraparib Synthesis & Characterization
 - Patent: "Process for the preparation of enantiomerically pure 2-phenyl piperidine derivatives." WO 2008/084261.
 - Source:

- General Piperidine Spectral Data
 - Database: National Institute of Advanced Industrial Science and Technology (AIST)
 - Source:
- Chiral Resolution Methods
 - Journal: "Synthesis of Poly(ADP-ribose) Polymerase Inhibitor Niraparib." [2] Organic Process Research & Development. (Discusses the purity profile of the (S)-isomer).
 - Source:
- Textbook: Pretsch, E., et al. "Structure Determination of Organic Compounds: Tables of Spectral Data." Springer.

Need Custom Synthesis?

BenchChem offers custom synthesis for rare earth carbides and specific isotopic labeling.

Email: info@benchchem.com or [Request Quote Online](#).

Sources

- [1. compoundchem.com \[compoundchem.com\]](https://www.compoundchem.com)
- [2. Niraparib Intermediates Manufacturer and Exporter in India | Enantilabs \[enantilabs.com\]](#)
- To cite this document: BenchChem. [Technical Guide: Spectral Interpretation of (S)-2-(3-Bromophenyl)piperidine]. BenchChem, [2026]. [Online PDF]. Available at: [\[https://www.benchchem.com/product/b1631101/docs#technical-guide-spectral-interpretation-of-s-2-3-bromophenyl-piperidine\]](https://www.benchchem.com/product/b1631101/docs#technical-guide-spectral-interpretation-of-s-2-3-bromophenyl-piperidine)

Disclaimer & Data Validity:

The information provided in this document is for Research Use Only (RUO) and is strictly not intended for diagnostic or therapeutic procedures. While BenchChem strives to provide accurate protocols, we make no warranties, express or implied, regarding the fitness of this product for every specific experimental setup.

Technical Support: The protocols provided are for reference purposes. Unsure if this reagent suits your experiment?

Need Industrial/Bulk Grade? [Request Custom Synthesis Quote](#)

BenchChem

Our mission is to be the trusted global source of essential and advanced chemicals, empowering scientists and researchers to drive progress in science and industry.

Contact

Address: 3281 E Guasti Rd
Ontario, CA 91761, United States
Phone: (601) 213-4426
Email: info@benchchem.com

[Contact our Ph.D. Support Team for a compatibility check](#)