

Optimizing L-Carnitine Fumarate dosage for maximal cellular uptake

Author: BenchChem Technical Support Team. **Date:** May 2026

Compound of Interest

Compound Name: *L-Carnitine fumarate*

Cat. No.: B1631465

[Get Quote](#)

Technical Support Center: L-Carnitine Fumarate

Welcome to the technical resource hub for researchers and drug development professionals working with **L-Carnitine Fumarate**. This guide is designed to provide in-depth, field-proven insights to help you optimize your experiments for maximal cellular uptake and troubleshoot common issues. Our approach is grounded in the fundamental biochemistry of L-Carnitine transport, ensuring that your experimental design is both logical and self-validating.

Frequently Asked Questions (FAQs)

This section addresses foundational questions that are crucial for designing and interpreting your experiments.

1. What is the primary role of **L-Carnitine Fumarate** in cellular metabolism? L-Carnitine is a vital nutrient that acts as a shuttle for long-chain fatty acids, transporting them from the cytosol into the mitochondrial matrix.^{[1][2][3]} This is a rate-limiting step for the β -oxidation of these fatty acids to produce ATP, the cell's primary energy currency.^{[1][3]} **L-Carnitine Fumarate** is a stable salt form of L-Carnitine, where the fumarate moiety is an intermediate in the Krebs (TCA) cycle, another core pathway of cellular energy production.^[4]

2. How does L-Carnitine enter the cell? The primary mechanism for L-Carnitine transport across the plasma membrane is through a high-affinity, sodium-dependent transporter known as Organic Cation/Carnitine Transporter Novel 2 (OCTN2), which is encoded by the SLC22A5 gene.[5][6][7][8] This transporter is ubiquitously expressed but is particularly abundant in tissues with high energy demands like skeletal and cardiac muscle.[1][7] The dependence on a sodium gradient means this is an active transport process, allowing cells to concentrate L-Carnitine against its concentration gradient.[5][9]

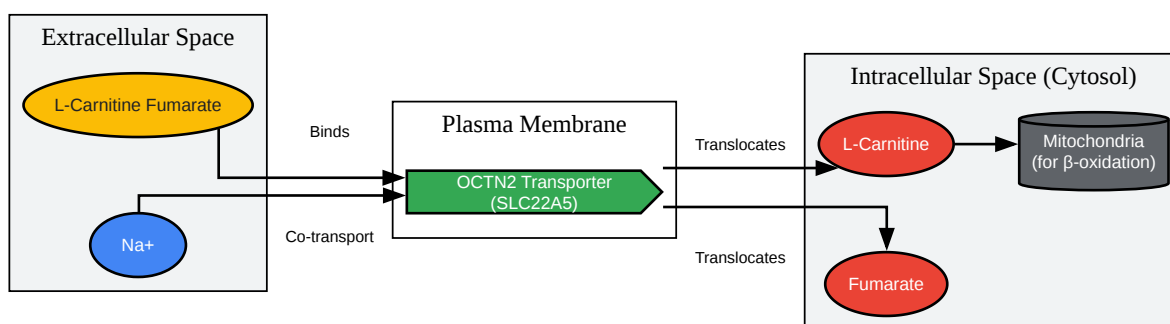

[Click to download full resolution via product page](#)

Caption: L-Carnitine cellular uptake via the OCTN2 transporter.

3. What are the key experimental factors influencing L-Carnitine uptake? Maximal uptake via OCTN2 is dependent on several critical factors that must be controlled in your in vitro system:

- **Sodium Ion Concentration:** As a Na⁺-dependent co-transporter, the presence of an extracellular sodium gradient is essential for OCTN2 activity.[5][9]
- **pH:** The transporter's activity is pH-sensitive. Studies have shown that transport activity can be influenced by extracellular pH, with some reports indicating maximal activity in a slightly acidic to neutral pH range.[9][10][11]
- **Energy Availability:** Cellular ATP is required to maintain the sodium gradient via the Na⁺/K⁺-ATPase pump. Depletion of cellular ATP will indirectly inhibit L-Carnitine uptake.[9]

- **Membrane Cholesterol:** The lipid microenvironment of the plasma membrane can modulate OCTN2 function. Cholesterol, in particular, has been shown to stimulate L-Carnitine influx by increasing the transporter's affinity.^{[5][6]}

4. What is a reasonable starting concentration for **L-Carnitine Fumarate** in cell culture experiments? Normal serum L-Carnitine levels in humans range from approximately 20-100 μM .^[12] For in vitro experiments, a starting point could be within this physiological range. However, to study kinetics or overcome potential limitations, concentrations ranging from 0.1 mM to 3 mM are often used.^[13] It is crucial to perform a dose-response curve for your specific cell line to determine the optimal concentration that maximizes uptake without inducing cytotoxicity.^{[13][14]}

5. How stable is **L-Carnitine Fumarate** in standard cell culture media? **L-Carnitine Fumarate** is a stable salt.^[4] L-Carnitine itself is generally stable in aqueous solutions, including typical cell culture media, under standard incubation conditions (37°C, 5% CO₂). However, for long-term experiments, it is always best practice to prepare fresh solutions or test for degradation if storage is necessary.

Troubleshooting Guides

This section provides structured, Q&A-style guides to address specific experimental challenges.

Problem 1: Low or No Detectable Intracellular L-Carnitine

Question: "My assay shows minimal to no increase in intracellular L-Carnitine after incubating my cells with **L-Carnitine Fumarate**. What could be wrong?"

Plausible Causes & Diagnostic Workflow: This issue often stems from one of four areas: compromised cell health, suboptimal transporter function, insufficient dosage, or assay-related problems. The following workflow will help you systematically identify the root cause.

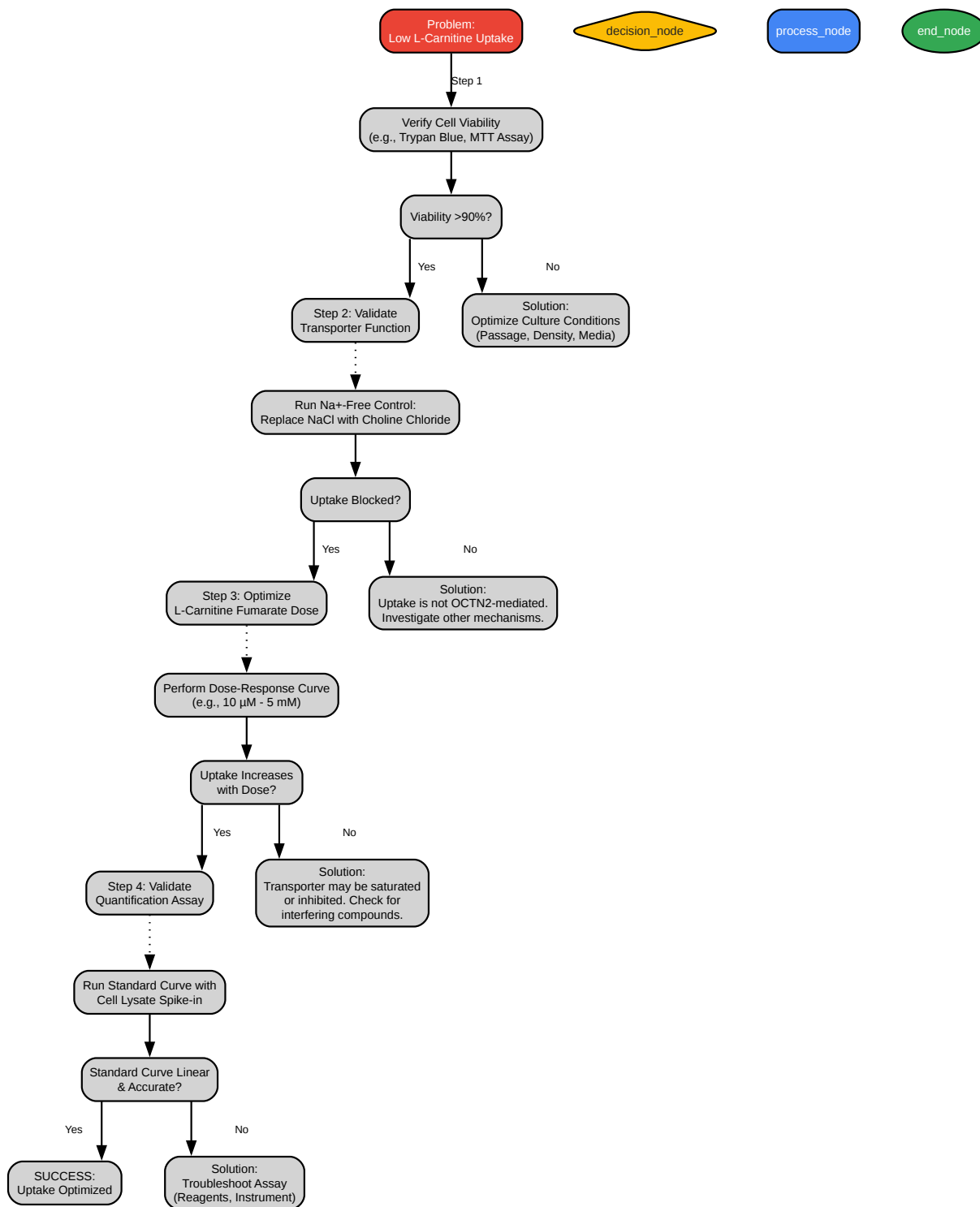

[Click to download full resolution via product page](#)

Caption: Troubleshooting workflow for low L-Carnitine uptake.

Recommended Action Plan:

Step 1: Verify Cell Health and Culture Conditions

- Rationale: Dead or unhealthy cells will not have the metabolic capacity or membrane integrity to actively transport nutrients.
- Protocol: Cell Viability Assessment
 - Culture your cells under the same conditions used in your uptake experiment.
 - Prior to the assay, perform a simple viability check using Trypan Blue exclusion. A viable culture should have >95% exclusion.
 - For a more quantitative measure, run an MTT or similar metabolic activity assay on a parallel plate.
 - Interpretation: If viability is low, troubleshoot your basic cell culture technique (e.g., check for contamination, ensure appropriate seeding density, use cells at a low passage number).

Step 2: Confirm OCTN2 Transporter Activity

- Rationale: To confirm that the uptake you are measuring is mediated by the specific Na⁺-dependent OCTN2 transporter, you must run a negative control where this mechanism is disabled.
- Protocol: Sodium-Dependence Test
 - Prepare two uptake buffers:
 - Control Buffer: A standard balanced salt solution containing NaCl (e.g., Hanks' Balanced Salt Solution).
 - Na⁺-Free Buffer: An identical buffer where NaCl is replaced with an equimolar concentration of an impermeable cation salt, such as Choline Chloride or N-methyl-D-glucamine.[9]

- Pre-incubate one set of cell wells with Control Buffer and another set with Na⁺-Free Buffer for 15-20 minutes.
- Perform the **L-Carnitine Fumarate** uptake assay in the respective buffers.
- Interpretation: You should observe a significant reduction (>80-90%) in L-Carnitine uptake in the Na⁺-Free Buffer compared to the Control Buffer.[9] If you do not see this reduction, it suggests that the uptake is primarily due to passive diffusion or a different, sodium-independent mechanism.

Step 3: Perform a Dose-Response and Time-Course Experiment

- Rationale: The concentration of **L-Carnitine Fumarate** may be too low to detect an increase, or the incubation time may be too short. A dose-response experiment will identify the concentration range where the transporter is active and not yet saturated.
- Protocol: Dose-Response Analysis
 - Seed cells in a multi-well plate (e.g., 24-well).
 - Prepare a range of **L-Carnitine Fumarate** concentrations in your assay buffer (e.g., 0, 10, 50, 100, 500, 1000, 3000 μM).
 - Incubate the cells with the different concentrations for a fixed time (e.g., 30 minutes).
 - Wash the cells thoroughly with ice-cold PBS to stop the transport process and remove extracellular L-Carnitine.
 - Lyse the cells and measure the intracellular L-Carnitine concentration.
 - Data Presentation & Interpretation: Plot intracellular L-Carnitine concentration against the extracellular concentration. You should see a saturable curve, characteristic of transporter-mediated uptake. This will reveal the optimal concentration for your experiments.

| Extracellular L-Carnitine (μM) | Intracellular L-Carnitine (nmol/mg protein) |
|---|---|
| 0 | 0.5 (Basal Level) |
| 10 | 1.8 |
| 50 | 7.5 |
| 100 | 12.3 |
| 500 | 25.1 |
| 1000 | 28.9 (Approaching Saturation) |
| 3000 | 29.5 (Saturated) |

Table 1: Example dose-response data for L-Carnitine uptake.

Problem 2: High Variability Between Experimental Replicates

Question: "I'm seeing a large standard deviation in my uptake data, making it difficult to draw conclusions. How can I improve my precision?"

Plausible Causes: Inconsistent cell numbers, temperature fluctuations during incubation, and imprecise timing of washing steps are the most common sources of variability.

Recommended Action Plan:

Step 1: Standardize Cell Seeding

- Rationale: Uptake data is typically normalized to cell number or total protein. If the starting number of cells per well is inconsistent, your normalized data will be highly variable.
- Protocol:
 - Always use a single, homogenous cell suspension for seeding an entire experiment.
 - Thoroughly mix the cell suspension before pipetting into each well to prevent settling.

- After seeding, visually inspect the plate under a microscope to confirm even cell distribution.

Step 2: Ensure Strict Temperature Control

- Rationale: L-Carnitine transport is an active, enzyme-like process that is highly sensitive to temperature.
- Protocol:
 - Pre-warm all buffers and L-Carnitine solutions to 37°C before adding them to the cells.
 - Perform the incubation step in a calibrated incubator to ensure a consistent 37°C.
 - Crucially, perform all wash steps with ice-cold buffer and on ice. This immediately halts the transport process, effectively "freezing" the experiment at a precise time point.

Step 3: Automate or Standardize Washing Steps

- Rationale: The time between ending the incubation and lysing the cells is critical. Any delay can allow L-Carnitine to leak out of the cells, and variability in washing efficiency can leave behind extracellular substrate.
- Protocol:
 - Use a multi-channel aspirator to remove media from multiple wells simultaneously.
 - Add ice-cold wash buffer immediately and consistently to all wells.
 - Repeat the wash step 2-3 times to ensure complete removal of extracellular L-Carnitine. Work quickly and consistently for each plate.

Problem 3: Observed Cellular Toxicity at Expected Therapeutic Doses

Question: "When I use **L-Carnitine Fumarate** at concentrations reported in the literature, I observe a decrease in cell viability. Why is this happening?"

Plausible Causes: While L-Carnitine is generally considered safe, high concentrations can induce cytotoxicity through osmotic stress or other mechanisms.[13][15] Your specific cell line may be more sensitive than those previously reported.

Recommended Action Plan:

Step 1: Perform a Comprehensive Cytotoxicity Assay

- Rationale: You must empirically determine the toxic threshold for your specific cell line and experimental duration.
- Protocol: LDH or MTT Cytotoxicity Assay
 - Seed cells in a 96-well plate.
 - Treat wells with a broad range of **L-Carnitine Fumarate** concentrations, extending beyond your planned experimental dose (e.g., from 100 μ M to 10 mM).
 - Include a positive control for toxicity (e.g., Triton X-100 for LDH assay) and an untreated negative control.
 - Incubate for the same duration as your planned uptake experiment (e.g., 24 hours).
 - Perform a standard LDH assay (measuring membrane damage) or MTT assay (measuring metabolic activity).
 - Interpretation: Plot cell viability (%) against **L-Carnitine Fumarate** concentration. This will define the maximum non-toxic concentration you can use in your experiments. Studies have shown that toxicity can increase significantly above 3 mM for some cell lines.[13]

| L-Carnitine Fumarate (mM) | Cell Viability (%) |
|---------------------------|--------------------|
| 0 (Control) | 100 |
| 0.5 | 98.5 |
| 1.0 | 97.2 |
| 3.0 | 94.1 |
| 5.0 | 75.3 |
| 10.0 | 42.8 |

Table 2: Example cytotoxicity data for an L-Carnitine Fumarate-sensitive cell line.

Problem 4: Inconsistent Results Across Different Cell Lines

Question: "I'm trying to replicate my L-Carnitine uptake experiment in a different cell line, but the results are completely different. Why?"

Plausible Cause: The expression level of the OCTN2 (SLC22A5) transporter can vary dramatically between different cell types and tissues.^{[7][16]} This is the most likely reason for disparate uptake efficiencies.

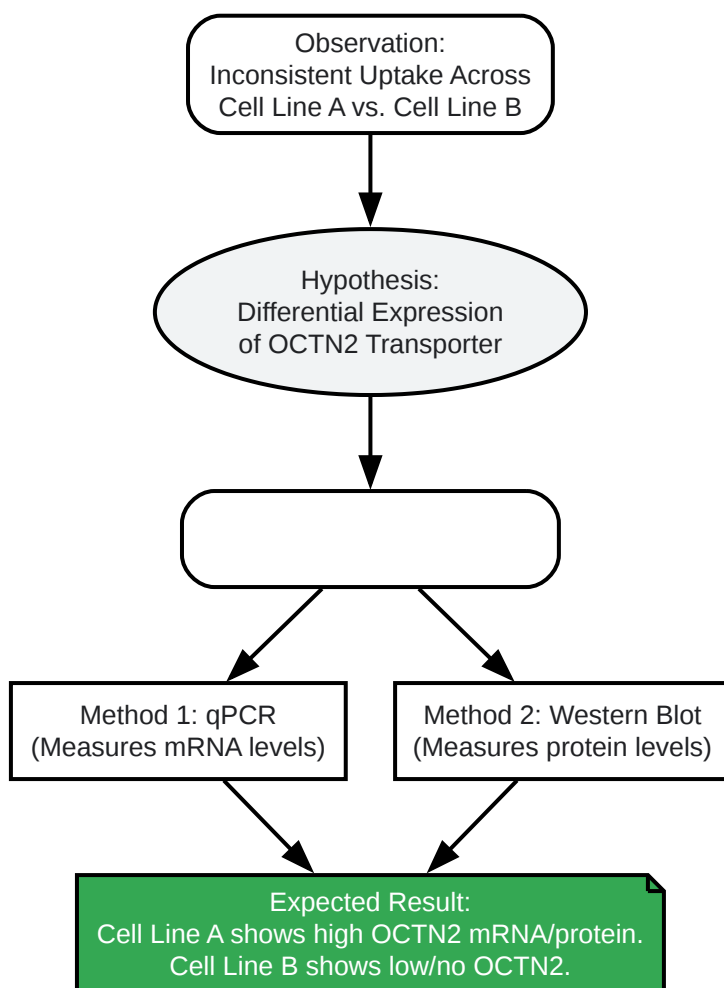

[Click to download full resolution via product page](#)

Caption: Logical relationship for investigating inconsistent cross-cell line results.

Recommended Action Plan:

Step 1: Quantify OCTN2 mRNA and Protein Expression

- Rationale: To correlate transporter abundance with uptake function, you must measure its expression at both the transcript and protein levels.
- Protocol: qPCR and Western Blot Analysis
 - qPCR for SLC22A5 mRNA:
 - Culture Cell Line A and Cell Line B to ~80% confluency.

- Harvest cells and extract total RNA.
- Perform reverse transcription to generate cDNA.
- Run quantitative PCR using validated primers for SLC22A5 and a stable housekeeping gene (e.g., GAPDH, ACTB) for normalization.
- Western Blot for OCTN2 Protein:
 - Lyse cells from both cell lines and quantify total protein.
 - Separate equal amounts of protein lysate via SDS-PAGE.
 - Transfer proteins to a PVDF or nitrocellulose membrane.
 - Probe the membrane with a validated primary antibody specific for OCTN2.
 - Use a loading control antibody (e.g., β -actin, GAPDH) to ensure equal protein loading.
- Interpretation: A direct comparison of the normalized SLC22A5 mRNA levels and OCTN2 protein bands between the two cell lines will confirm whether differential expression is the cause of the varied uptake results.

References

- Wikipedia. Carnitine. [[Link](#)]
- Linus Pauling Institute. L-Carnitine. [[Link](#)]
- The Alteration of L-Carnitine Transport and Pretreatment Effect under Glutamate Cytotoxicity on Motor Neuron-Like NSC-34 Lines. MDPI. [[Link](#)]
- Kinetics, pharmacokinetics, and regulation of L-carnitine and acetyl-L-carnitine metabolism. American Journal of Physiology-Endocrinology and Metabolism. [[Link](#)]
- L-Carnitine: Benefits, Side Effects, Sources, and Dosage. Healthline. [[Link](#)]
- Cholesterol stimulates the cellular uptake of L-carnitine by the carnitine/organic cation transporter novel 2 (OCTN2). ResearchGate. [[Link](#)]

- Carnitine Shuttle | Purpose and Mechanism. YouTube. [\[Link\]](#)
- Cholesterol stimulates the cellular uptake of L-carnitine by the carnitine/organic cation transporter novel 2 (OCTN2). Journal of Lipid Research. [\[Link\]](#)
- Carnitine Deficiency. StatPearls - NCBI Bookshelf. [\[Link\]](#)
- Carnitine - Health Professional Fact Sheet. Office of Dietary Supplements (ODS). [\[Link\]](#)
- SLC22A5 (OCTN2) Carnitine Transporter—Indispensable for Cell Metabolism, a Jekyll and Hyde of Human Cancer. Molecules. [\[Link\]](#)
- Effect of pH on the reconstituted carnitine transporter. ResearchGate. [\[Link\]](#)
- Effects of L-carnitine against oxidative stress in human hepatocytes: involvement of peroxisome proliferator-activated receptor alpha. Journal of Biomedical Science. [\[Link\]](#)
- Supplementation of culture medium with L-carnitine improves development and cryotolerance of bovine embryos produced in vitro. Reproduction, Fertility and Development. [\[Link\]](#)
- The bright and the dark sides of L-carnitine supplementation: a systematic review. European Journal of Applied Physiology. [\[Link\]](#)
- The Role of L-Carnitine in Mitochondria, Prevention of Metabolic Inflexibility and Disease Initiation. MDPI. [\[Link\]](#)
- L-Carnitine and Acetyl-L-Carnitine Induce Metabolism Alteration and Mitophagy-Related Cell Death in Colorectal Cancer Cells. MDPI. [\[Link\]](#)
- OCTN2 - Transporters. Solvo Biotechnology. [\[Link\]](#)
- Dietary supplementation with L-carnitine elevates intracellular carnitine levels and affects gene expression of SLC25A20 and COX4I1, as well as non-mitochondrial respiration of bovine blood cells during systemic immune challenge. PLOS ONE. [\[Link\]](#)
- Tissue culture media containing L-carnitine.

- Diagnosis of Carnitine Deficiency in Extremely Preterm Neonates Related to Parenteral Nutrition: Two Step Newborn Screening Approach. Cureus. [\[Link\]](#)
- L-carnitine protects C2C12 cells against mitochondrial superoxide overproduction and cell death. Frontiers in Bioscience. [\[Link\]](#)
- Half-maximal effect of extracellular pH on saturable transport of L-carnitine in RAECs. ResearchGate. [\[Link\]](#)
- L-carnitine Assay Kit. CliniSciences. [\[Link\]](#)
- Organic cation/carnitine Transporter, OCTN2, Transcriptional Activity Is Regulated by Osmotic Stress in Epididymal Cells. Molecular Reproduction and Development. [\[Link\]](#)
- Assessing the In Vitro and In Vivo Performance of L-Carnitine-Loaded Nanoparticles in Combating Obesity. Pharmaceuticals. [\[Link\]](#)
- CARNITINE TRANSPORT AND FATTY ACID OXIDATION. Biochimica et Biophysica Acta. [\[Link\]](#)
- The Effect of L-Carnitine Supplementation in Culture Medium on the Development and Cryopreservation of in Vitro Produced Bovine Embryos. Reproduction in Domestic Animals. [\[Link\]](#)
- Newborn screening information for Carnitine uptake defect. Baby's First Test. [\[Link\]](#)
- The determination of L-carnitine in several food samples. ResearchGate. [\[Link\]](#)
- SLC22A5 (OCTN2) Carnitine Transporter-Indispensable for Cell Metabolism, a Jekyll and Hyde of Human Cancer. Molecules. [\[Link\]](#)
- Carnitine Deficiency Workup: Laboratory Studies, Imaging Studies, Other Tests. Medscape. [\[Link\]](#)
- Effects of substrate binding and pH on the secondary structure of carnitine acetyltransferase. Protein and Peptide Letters. [\[Link\]](#)
- Primary carnitine deficiency. Newborn Screening - HRSA. [\[Link\]](#)

- L-Carnitine Suppresses Transient Receptor Potential Vanilloid Type 1 Activation in Human Corneal Epithelial Cells. MDPI. [[Link](#)]

Need Custom Synthesis?

BenchChem offers custom synthesis for rare earth carbides and specific isotopic labeling.

Email: info@benchchem.com or [Request Quote Online](#).

Sources

- 1. Carnitine - Wikipedia [en.wikipedia.org]
- 2. L-Carnitine: Benefits, Side Effects, Sources, and Dosage [[healthline.com](https://www.healthline.com)]
- 3. m.youtube.com [m.youtube.com]
- 4. L-Carnitine Tartrate and L-Carnitine Fumarate - Qingdao Sensure [[sensurebio.com](https://www.sensurebio.com)]
- 5. [researchgate.net](https://www.researchgate.net) [[researchgate.net](https://www.researchgate.net)]
- 6. Cholesterol stimulates the cellular uptake of L-carnitine by the carnitine/organic cation transporter novel 2 (OCTN2) - PMC [[pmc.ncbi.nlm.nih.gov](https://pubmed.ncbi.nlm.nih.gov)]
- 7. SLC22A5 (OCTN2) Carnitine Transporter—Indispensable for Cell Metabolism, a Jekyll and Hyde of Human Cancer - PMC [[pmc.ncbi.nlm.nih.gov](https://pubmed.ncbi.nlm.nih.gov)]
- 8. OCTN2 - Transporters - Solvo Biotechnology [[solvobiotech.com](https://www.solvobiotech.com)]
- 9. [mdpi.com](https://www.mdpi.com) [[mdpi.com](https://www.mdpi.com)]
- 10. [researchgate.net](https://www.researchgate.net) [[researchgate.net](https://www.researchgate.net)]
- 11. [researchgate.net](https://www.researchgate.net) [[researchgate.net](https://www.researchgate.net)]
- 12. L-Carnitine Assay Kit (ab83392) | Abcam [[abcam.com](https://www.abcam.com)]
- 13. Effects of L-carnitine against oxidative stress in human hepatocytes: involvement of peroxisome proliferator-activated receptor alpha - PMC [[pmc.ncbi.nlm.nih.gov](https://pubmed.ncbi.nlm.nih.gov)]
- 14. Supplementation of culture medium with L-carnitine improves development and cryotolerance of bovine embryos produced in vitro - PubMed [pubmed.ncbi.nlm.nih.gov]
- 15. L-carnitine protects C2C12 cells against mitochondrial superoxide overproduction and cell death - PMC [[pmc.ncbi.nlm.nih.gov](https://pubmed.ncbi.nlm.nih.gov)]
- 16. SLC22A5 (OCTN2) Carnitine Transporter-Indispensable for Cell Metabolism, a Jekyll and Hyde of Human Cancer - PubMed [pubmed.ncbi.nlm.nih.gov]

- To cite this document: BenchChem. [Optimizing L-Carnitine Fumarate dosage for maximal cellular uptake]. BenchChem, [2026]. [Online PDF]. Available at: [<https://www.benchchem.com/product/b1631465/docs#optimizing-l-carnitine-fumarate-dosage-for-maximal-cellular-uptake>]

Disclaimer & Data Validity:

The information provided in this document is for Research Use Only (RUO) and is strictly not intended for diagnostic or therapeutic procedures. While BenchChem strives to provide accurate protocols, we make no warranties, express or implied, regarding the fitness of this product for every specific experimental setup.

Technical Support: The protocols provided are for reference purposes. Unsure if this reagent suits your experiment?

Need Industrial/Bulk Grade? [Request Custom Synthesis Quote](#)

BenchChem

Our mission is to be the trusted global source of essential and advanced chemicals, empowering scientists and researchers to drive progress in science and industry.

Contact

Address: 3281 E Guasti Rd
Ontario, CA 91761, United States
Phone: (601) 213-4426
Email: info@benchchem.com

[Contact our Ph.D. Support Team for a compatibility check](#)