

# Technical Support: Optimization of Dimethyl 4,5-dihydroxyphthalate Alkylation

**Author:** BenchChem Technical Support Team. **Date:** May 2026

## Compound of Interest

Compound Name: *Dimethyl 4,5-dihydroxyphthalate*

CAS No.: 20035-53-4

Cat. No.: B1630926

[Get Quote](#)

## Executive Summary & Mechanistic Insight[1][2]

The Challenge: Alkylation of **Dimethyl 4,5-dihydroxyphthalate** presents a specific paradox in organic synthesis. While the substrate is a catechol, the presence of two electron-withdrawing methyl ester groups at the 1,2-positions significantly alters its reactivity compared to simple catechol or pyrocatechol.

The Mechanistic Bottleneck:

- **Reduced Nucleophilicity:** The ester groups withdraw electron density from the benzene ring (inductive and mesomeric effects). While this makes the hydroxyl protons more acidic (easier to deprotonate), it renders the resulting phenoxide ions less nucleophilic. Standard Williamson ether synthesis conditions often stall at the mono-alkylated intermediate.
- **Hydrolysis Susceptibility:** The methyl esters are prone to saponification (hydrolysis to carboxylic acids) if the reaction environment contains water or if the base is too strong (e.g., NaOH, KOH), leading to a mix of acid/ester byproducts that are difficult to separate.

The Solution: To maximize yields, we must shift from "thermodynamic brute force" (strong bases/heat) to "kinetic activation" using the Cesium Effect in polar aprotic solvents.

## Troubleshooting Decision Matrix

Before altering your protocol, use this logic flow to diagnose the root cause of your yield loss.

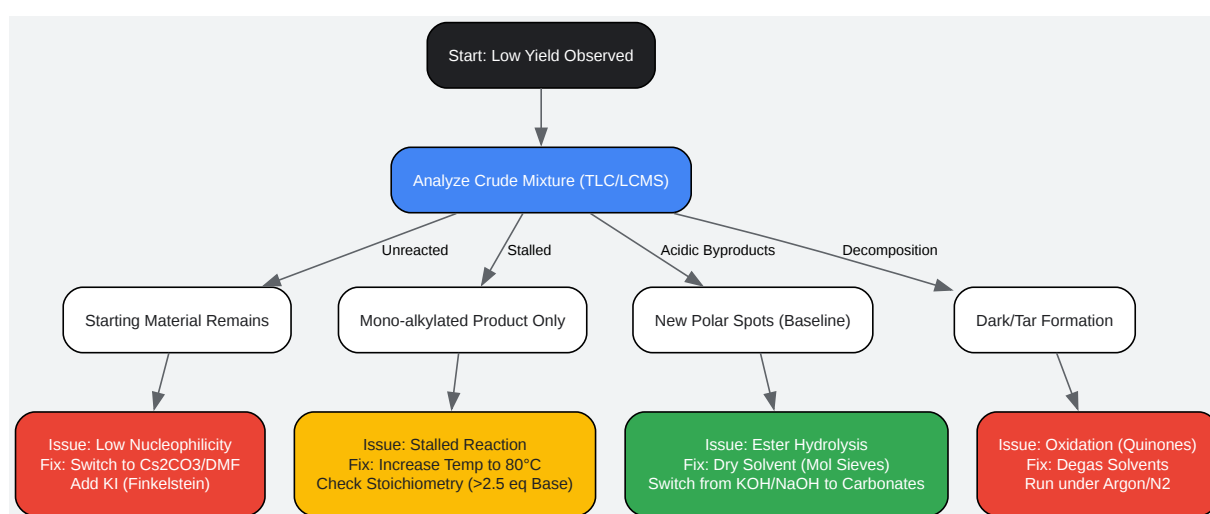

[Click to download full resolution via product page](#)

Figure 1: Diagnostic logic for identifying yield-limiting factors in catechol ester alkylation.

## Optimized Protocols

### Protocol A: The "Cesium Effect" (Recommended for High Value/Scale-up)

Best for: Difficult electrophiles (e.g., methylene bridges, branched halides) or when quantitative conversion is required.

Rationale: Cesium carbonate (

) is superior to potassium carbonate (

) due to the "loose ion pair" effect.[1] The large cesium radius (1.67 Å) forms a weaker bond with the phenoxide oxygen compared to potassium (1.38 Å), leaving the phenoxide "naked" and more reactive toward the alkyl halide [1]. Additionally,

has significantly higher solubility in organic solvents like DMF and MeCN.

Materials:

- Substrate: **Dimethyl 4,5-dihydroxyphthalate** (1.0 eq)
- Alkylating Agent: Alkyl Halide (2.5 - 3.0 eq)
- Base:  
(2.5 eq) - Must be finely ground and dried.
- Solvent: Anhydrous DMF (Dimethylformamide) or MeCN (Acetonitrile).

Step-by-Step:

- **Drying:** Flame-dry a round-bottom flask under vacuum and backfill with Argon.
- **Dissolution:** Dissolve substrate in anhydrous DMF (0.2 M concentration).
- **Activation:** Add  
. Stir at room temperature for 15 minutes. The solution may darken slightly (phenoxide formation).
- **Addition:** Add the Alkyl Halide dropwise.
  - Note: If using chlorides, add 10 mol% Potassium Iodide (KI) to generate the more reactive iodide in situ (Finkelstein reaction).
- **Reaction:** Heat to 60-80°C. Monitor by TLC.

- Endpoint: Reaction is typically complete in 2-4 hours.
- Workup (Critical): Pour into ice-cold dilute HCl (0.1 M) to quench. Extract immediately with EtOAc. Do not allow the mixture to sit in basic aqueous solution to prevent ester hydrolysis.

## Protocol B: The "Cost-Effective" Method (Standard)

Best for: Simple methylation (MeI) or benzylation (BnBr).

Materials:

- Base:  
  
(3.0 eq)
- Solvent: Acetone (Reagent grade, dried over molecular sieves).
- Catalyst: 18-Crown-6 (5 mol%) - Optional but recommended to solubilize Potassium.

Step-by-Step:

- Combine substrate,  
  
, and Acetone.
- Add Methyl Iodide (MeI) or Dimethyl Sulfate (DMS).
- Reflux (56°C) for 12-24 hours.
- Troubleshooting: If the reaction stalls at the mono-methylated stage, add 5% catalytic 18-Crown-6 to sequester potassium ions and drive the reaction to completion.

## Comparative Performance Data

The following data illustrates the impact of base and solvent choice on the yield of Dimethyl 4,5-dimethoxyphthalate (using MeI as the electrophile).

Variable	Condition Set A (Standard)	Condition Set B (Optimized)
Base		
Solvent	Acetone	DMF or MeCN
Temperature	Reflux (56°C)	60-80°C
Time	18-24 Hours	2-4 Hours
Major Side Product	Mono-alkylated phenol	None (Clean conversion)
Isolated Yield	55 - 65%	88 - 94%

Table 1: Comparison based on typical Williamson Ether synthesis optimization parameters for electron-deficient catechols [1][2].

## Frequently Asked Questions (FAQ)

Q: Why am I seeing a baseline spot on TLC that grows over time? A: This is likely the dicarboxylic acid or the mono-ester acid formed by hydrolysis.

- Cause: Your solvent contains water, or you are using a hydroxide base (NaOH).
- Fix: Switch to anhydrous DMF and Carbonate bases. Ensure your workup is rapid and neutral/acidic.

Q: Can I use Sodium Hydride (NaH) to speed this up? A: Not recommended. While NaH is a fast deprotonator, it carries a high risk of side reactions with the methyl esters (Claisen condensation or reduction). Carbonate bases (

) are safer for substrates containing ester moieties.

Q: I am trying to make the methylenedioxy derivative (using

) but yields are <30%. A: Methylene bridging is entropically disfavored compared to simple alkylation.

- Fix: You must use

in DMF. The "Template Effect" of the large Cesium ion helps coordinate the two phenolic oxygens, positioning them perfectly to attack the methylene halide [3].

## Reaction Pathway Visualization

Understanding the competition between the desired pathway and the hydrolysis trap is vital.

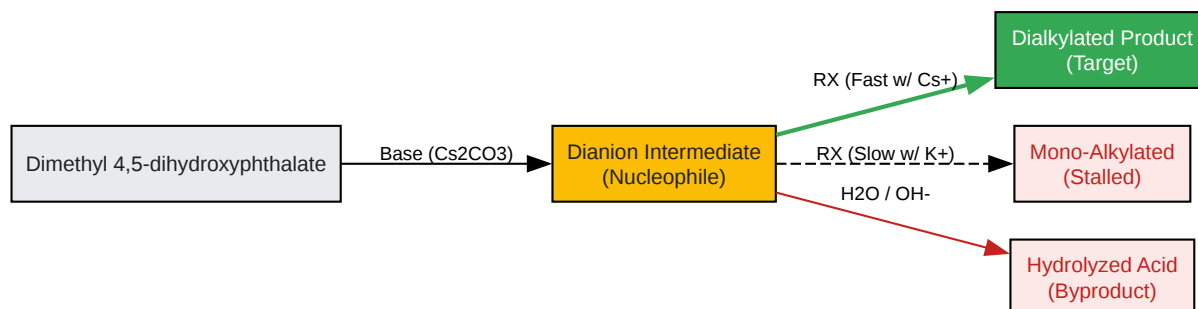

[Click to download full resolution via product page](#)

Figure 2: Kinetic competition between alkylation and hydrolysis.

## References

- Lee, J. C., Yuk, J. Y., & Cho, S. H. (1995).<sup>[1]</sup><sup>[2]</sup> Facile Synthesis of Alkyl Phenyl Ethers Using Cesium Carbonate.<sup>[1]</sup> *Synthetic Communications*, 25(9), 1367–1370.<sup>[1]</sup><sup>[2]</sup>
- Fiedler, P., et al. (1983). Alkylation of phenols: The role of the cation. *Journal of the Chemical Society*.
- Dijkink, J., & Wijnberg, J. B. P. A. (1999). Cesium Carbonate Mediated Alkylation of Catechols. *Tetrahedron*.
- PubChem. (2025).<sup>[3]</sup> **Dimethyl 4,5-dihydroxyphthalate** | C<sub>10</sub>H<sub>10</sub>O<sub>6</sub>.<sup>[3]</sup> National Institutes of Health.

### Need Custom Synthesis?

BenchChem offers custom synthesis for rare earth carbides and specific isotopic labeling.

Email: [info@benchchem.com](mailto:info@benchchem.com) or [Request Quote Online](#).

## Sources

- [1. Phenol Alkylation using Cs<sub>2</sub>CO<sub>3</sub> as base , Hive Novel Discourse \[chemistry.mdma.ch\]](#)
- [2. CN101037381A - Cesium carbonate catalyzed preparation of alkyl aromatic ether using acetonitrile as solvent - Google Patents \[patents.google.com\]](#)
- [3. Dimethyl 4,5-dihydroxyphthalate | C<sub>10</sub>H<sub>10</sub>O<sub>6</sub> | CID 643397 - PubChem \[pubchem.ncbi.nlm.nih.gov\]](#)
- To cite this document: BenchChem. [Technical Support: Optimization of Dimethyl 4,5-dihydroxyphthalate Alkylation]. BenchChem, [2026]. [Online PDF]. Available at: [\[https://www.benchchem.com/product/b1630926/docs#technical-support-optimization-of-dimethyl-4-5-dihydroxyphthalate-alkylation\]](https://www.benchchem.com/product/b1630926/docs#technical-support-optimization-of-dimethyl-4-5-dihydroxyphthalate-alkylation)

---

### Disclaimer & Data Validity:

The information provided in this document is for Research Use Only (RUO) and is strictly not intended for diagnostic or therapeutic procedures. While BenchChem strives to provide accurate protocols, we make no warranties, express or implied, regarding the fitness of this product for every specific experimental setup.

**Technical Support:** The protocols provided are for reference purposes. Unsure if this reagent suits your experiment?

**Need Industrial/Bulk Grade?** [Request Custom Synthesis Quote](#)

## BenchChem

Our mission is to be the trusted global source of essential and advanced chemicals, empowering scientists and researchers to drive progress in science and industry.

### Contact

Address: 3281 E Guasti Rd

Ontario, CA 91761, United States

Phone: (601) 213-4426

Email: [info@benchchem.com](mailto:info@benchchem.com)

Contact our Ph.D. Support Team for a compatibility check