

Cell-Based Assays to Study 15(R)-HETE Activity and Pro-Resolving Signaling

Author: BenchChem Technical Support Team. **Date:** April 2026

Compound of Interest

Compound Name:	15(R)-Hete
CAS No.:	73836-87-0
Cat. No.:	B163585

[Get Quote](#)

Biological Context and Mechanistic Framework

Aspirin's pharmacological mechanism extends far beyond the simple inhibition of pro-inflammatory prostaglandins. When aspirin irreversibly acetylates cyclooxygenase-2 (COX-2) at the Serine 530 residue, it sterically blocks the binding of arachidonic acid to the canonical catalytic core[1]. However, rather than simply destroying the enzyme's function, this modification fundamentally alters its catalytic activity. The acetylated COX-2 is converted into a 15(R)-lipoxygenase, which oxygenates arachidonic acid to form 15(R)-hydroxyeicosatetraenoic acid (**15(R)-HETE**)[1][2][3].

Unlike its enantiomer 15(S)-HETE, **15(R)-HETE** serves as a critical intermediate in the biosynthesis of Aspirin-Triggered Lipoxins (AT-Lipoxins)[4]. Through a process known as transcellular biosynthesis, **15(R)-HETE** produced by endothelial or epithelial cells is secreted and subsequently taken up by adjacent leukocytes. Inside the leukocyte, 5-lipoxygenase (5-LOX) converts **15(R)-HETE** into 15-epi-lipoxin A4 (15-epi-LXA4)[1][5]. This potent Specialized Pro-resolving Mediator (SPM) binds to the ALX/FPR2 G-protein coupled receptor to actively promote the resolution of inflammation, enhance macrophage efferocytosis, and inhibit polymorphonuclear neutrophil (PMN) infiltration[1][4].

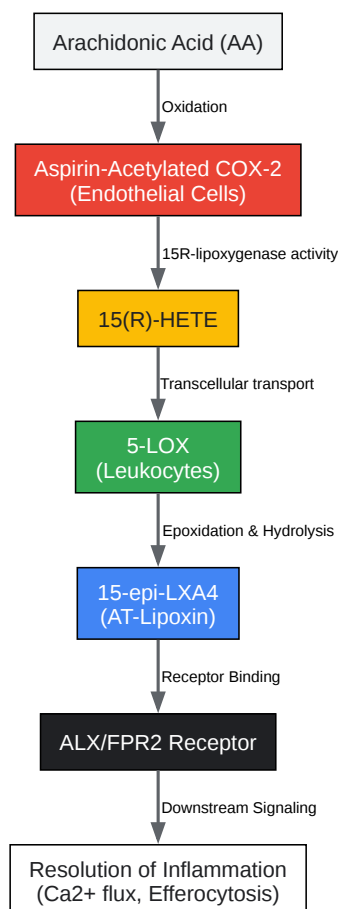

[Click to download full resolution via product page](#)

Aspirin-triggered **15(R)-HETE** biosynthesis and ALX/FPR2 pro-resolving signaling pathway.

Experimental Design & Causality

To accurately study **15(R)-HETE**, researchers must account for its nature as a pro-resolving intermediate. Assays must either evaluate its conversion into 15-epi-LXA4 via transcellular models or measure the downstream ALX/FPR2 receptor activation and phenotypic resolution.

- Why utilize a Co-culture System? Monocultures of endothelial cells cannot produce 15-epi-LXA4 because they lack 5-LOX. Conversely, monocultures of neutrophils cannot produce **15(R)-HETE** because they lack COX-2. A co-culture system is the only self-validating physiological model that mimics the transcellular handoff required for **15(R)-HETE** metabolism[1][4].
- Why use transfected HEK293 cells for GPCR Assays? Native immune cells like HL-60 express multiple formyl peptide receptors (FPR1, FPR2, FPR3). To isolate the specific activity of **15(R)-HETE** metabolites on the ALX/FPR2 receptor without cross-reactivity confounding the data, an ALX/FPR2-transfected HEK293 cell line provides a clean, null background[5].

Core Experimental Protocols

Protocol 1: Transcellular Biosynthesis Co-Culture Assay

Rationale: Validates the conversion of **15(R)-HETE** to 15-epi-LXA4 between endothelial cells and neutrophils.

Self-Validation Mechanism: This assay includes a vehicle control (no aspirin) to demonstrate the baseline production of 15(S)-HETE. The shift from 15(S)-HETE to **15(R)-HETE** upon aspirin addition internally validates the acetylation of COX-2[3].

- Endothelial Cell Preparation: Seed Human Umbilical Vein Endothelial Cells (HUVECs) in a 6-well plate at 2×10^5 cells/well. Grow to 90% confluence in EGM-2 medium.
- COX-2 Induction & Acetylation: Stimulate HUVECs with IL-1 β (10 ng/mL) for 24 hours to upregulate COX-2 expression. Wash cells with PBS, then incubate with Aspirin (100 μ M) for 30 minutes at 37°C to acetylate COX-2.
- Neutrophil Isolation & Co-culture: Isolate primary human PMNs from whole blood using density gradient centrifugation. Add 1×10^6 PMNs to the HUVEC monolayer in HBSS buffer

containing Ca²⁺ and Mg²⁺ .

- Pathway Activation: Initiate lipid mediator biosynthesis by adding Arachidonic Acid (10 μM) and calcium ionophore A23187 (2.5 μM) for 30 minutes at 37°C.
- Extraction & LC-MS/MS Analysis: Stop the reaction with 2 volumes of ice-cold methanol containing deuterated internal standards (e.g., d4-PGE2). Extract lipids using solid-phase extraction (SPE) and quantify **15(R)-HETE** and 15-epi-LXA4 via chiral-phase LC-MS/MS[3].

Protocol 2: ALX/FPR2 Calcium Mobilization Assay

Rationale: Measures the real-time GPCR activation induced by **15(R)-HETE** and its downstream metabolites.

Self-Validation Mechanism: The inclusion of WRW4, a specific FPR2 antagonist, ensures that any observed calcium flux is strictly dependent on ALX/FPR2 activation, ruling out off-target effects[5].

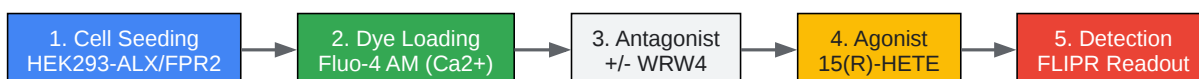

[Click to download full resolution via product page](#)

Step-by-step workflow for the ALX/FPR2 calcium mobilization assay.

- Cell Plating: Seed HEK293 cells stably expressing human ALX/FPR2 at 3×10⁴ cells/well in a 96-well black, clear-bottom plate. Incubate overnight.

- **Dye Loading:** Remove media and add 100 μL of Fluo-4 AM dye loading solution (2 μM Fluo-4 AM, 0.02% Pluronic F-127 in assay buffer). Incubate for 45 minutes at 37°C in the dark.
- **Antagonist Pre-incubation:** Wash cells twice with assay buffer. To the antagonist control wells, add 10 μM WRW4 and incubate for 15 minutes.
- **Kinetic Readout:** Transfer the plate to a Fluorescent Imaging Plate Reader (FLIPR). Establish a 10-second baseline, then automatically inject varying concentrations of **15(R)-HETE** (1 nM to 10 μM) or 15-epi-LXA4.
- **Data Acquisition:** Record fluorescence (Ex 488 nm / Em 525 nm) for 120 seconds. Calculate the maximum Relative Fluorescence Units (RFU) minus baseline to determine the EC50.

Protocol 3: Macrophage Efferocytosis Phenotypic Assay

Rationale: Evaluates the ultimate biological function of **15(R)-HETE** pathway activation—the clearance of apoptotic cells to resolve inflammation.

Self-Validation Mechanism: Cytochalasin D (10 μM) is used as a negative control to inhibit actin polymerization. This validates that the measured fluorescence is due to true internalization (phagocytosis) rather than superficial binding of apoptotic bodies to the macrophage surface.

- **Macrophage Differentiation:** Differentiate THP-1 monocytes into M0 macrophages using 50 ng/mL PMA for 48 hours.
- **Apoptotic Cell Preparation:** Induce apoptosis in Jurkat T-cells using UV irradiation (254 nm for 15 mins) followed by a 3-hour incubation. Label the apoptotic cells with a pH-sensitive dye (e.g., pHrodo Red), which only fluoresces in the acidic environment of a phagolysosome.
- **Treatment:** Pre-treat the THP-1 macrophages with **15(R)-HETE** (1 μM) or vehicle for 1 hour. In parallel, treat control wells with Cytochalasin D.
- **Co-incubation:** Add the labeled apoptotic Jurkat cells to the macrophages at a 5:1 ratio. Incubate for 2 hours at 37°C.
- **Quantification:** Wash away non-engulfed cells. Measure the Phagocytic Index (percentage of macrophages containing red fluorescent apoptotic bodies) using high-content fluorescence

microscopy.

Quantitative Data Presentation

The table below summarizes the expected pharmacological profiles and biological readouts when evaluating **15(R)-HETE** and its related pathway components in the aforementioned assays.

Compound / Condition	Target / Pathway	ALX/FPR2 Calcium Flux (EC50)	Efferocytosis (Phagocytic Index)	Biological Effect
Vehicle (Control)	Baseline	N/A	~15%	Baseline clearance
15(S)-HETE	Canonical LOX product	> 10 μ M (Weak/Inactive)	~18%	Pro-inflammatory / Neutral
15(R)-HETE	Intermediate / Weak Agonist	~1.5 μ M	~35%	Precursor to resolution
15-epi-LXA4	ALX/FPR2 Agonist	~0.1 - 0.5 nM	~65%	Potent pro-resolving activity
15-epi-LXA4 + WRW4	ALX/FPR2 Antagonism	Abrogated	~16%	Confirms receptor specificity
15(R)-HETE + Cytochalasin D	Actin Inhibition	N/A	< 5%	Validates true internalization

Need Custom Synthesis?

BenchChem offers custom synthesis for rare earth carbides and specific isotopic labeling.

Email: info@benchchem.com or [Request Quote Online](#).

Sources

- [1. Specialized Pro-resolving Mediators in Atherosclerosis | Encyclopedia MDPI \[encyclopedia.pub\]](#)
- [2. Frontiers | Aspirin-triggered DHA metabolites inhibit angiogenesis \[frontiersin.org\]](#)
- [3. Residual cyclooxygenase activity of aspirin-acetylated COX-2 forms 15R-prostaglandins that inhibit platelet aggregation - PMC \[pmc.ncbi.nlm.nih.gov\]](#)
- [4. mdpi.com \[mdpi.com\]](#)
- [5. pubs.acs.org \[pubs.acs.org\]](#)
- To cite this document: BenchChem. [Cell-Based Assays to Study 15(R)-HETE Activity and Pro-Resolving Signaling]. BenchChem, [2026]. [Online PDF]. Available at: [\[https://www.benchchem.com/product/b163585/docs#cell-based-assays-to-study-15-r-hete-activity-and-pro-resolving-signaling\]](https://www.benchchem.com/product/b163585/docs#cell-based-assays-to-study-15-r-hete-activity-and-pro-resolving-signaling)

Disclaimer & Data Validity:

The information provided in this document is for Research Use Only (RUO) and is strictly not intended for diagnostic or therapeutic procedures. While BenchChem strives to provide accurate protocols, we make no warranties, express or implied, regarding the fitness of this product for every specific experimental setup.

Technical Support: The protocols provided are for reference purposes. Unsure if this reagent suits your experiment?

Need Industrial/Bulk Grade? [Request Custom Synthesis Quote](#)

BenchChem

Our mission is to be the trusted global source of essential and advanced chemicals, empowering scientists and researchers to drive progress in science and industry.

Contact

Address: 3281 E Guasti Rd
Ontario, CA 91761, United States
Phone: (601) 213-4426
Email: info@benchchem.com

Contact our Ph.D. Support Team for a compatibility check