

Application Notes and Protocols for the Reductive Amination Synthesis of Piperazines

Author: BenchChem Technical Support Team. **Date:** April 2026

Compound of Interest

Compound Name: 3-(4-Methylpiperazin-1-yl)butan-1-amine

CAS No.: 4553-30-4

Cat. No.: B1629644

[Get Quote](#)

For Researchers, Scientists, and Drug Development Professionals

The piperazine scaffold is a cornerstone in medicinal chemistry, recognized as a "privileged structure" due to its frequent appearance in a vast array of biologically active compounds and approved drugs.[1][2][3] Its unique six-membered heterocyclic structure with two nitrogen atoms at the 1 and 4 positions imparts desirable physicochemical properties, including conformational flexibility and tunable basicity, which are crucial for molecular recognition at biological targets.[4] Reductive amination stands out as a highly versatile and widely employed method for the synthesis and functionalization of the piperazine ring, offering a controlled and efficient route to a diverse range of derivatives.[5][6]

This guide provides an in-depth exploration of reductive amination protocols for piperazine synthesis, detailing the underlying mechanisms, comparing key reducing agents, and presenting step-by-step experimental procedures.

The Principle of Reductive Amination in Piperazine Synthesis

Reductive amination is a powerful chemical reaction that forms amines from carbonyl compounds (aldehydes or ketones) and ammonia or an amine.^{[7][8]} In the context of piperazine synthesis, this typically involves the reaction of a 1,2-diamine with a 1,2-dicarbonyl compound or a related precursor. The reaction proceeds through the in-situ formation of an imine or iminium ion intermediate, which is then reduced by a suitable reducing agent to yield the saturated piperazine ring.^{[9][10]}

A key advantage of this method is its ability to be performed as a "one-pot" synthesis, where all reactants are combined in a single reaction vessel, streamlining the process and improving overall efficiency.^{[11][12]}

Key Reagents and Mechanistic Considerations

The choice of reducing agent is critical in reductive amination and is dictated by the specific substrates and desired reaction conditions. Several reagents have proven effective, each with its own set of advantages and limitations.

Sodium Triacetoxyborohydride (NaBH(OAc)₃)

Sodium triacetoxyborohydride, often abbreviated as STAB, is a mild and selective reducing agent that has become a workhorse in reductive amination.^{[11][13]} Its reduced reactivity compared to other borohydrides allows it to selectively reduce the iminium ion intermediate in the presence of the starting carbonyl compound.^[14] This selectivity is crucial for one-pot procedures, preventing the premature reduction of the aldehyde or ketone.^[15]

The reaction is typically carried out in aprotic solvents like 1,2-dichloroethane (DCE), dichloromethane (DCM), or tetrahydrofuran (THF).^[13] The mechanism involves the formation of an iminium ion from the condensation of the amine and carbonyl groups, which is then reduced by the hydride delivered from the triacetoxyborohydride.

Diagram: Generalized Mechanism of Reductive Amination

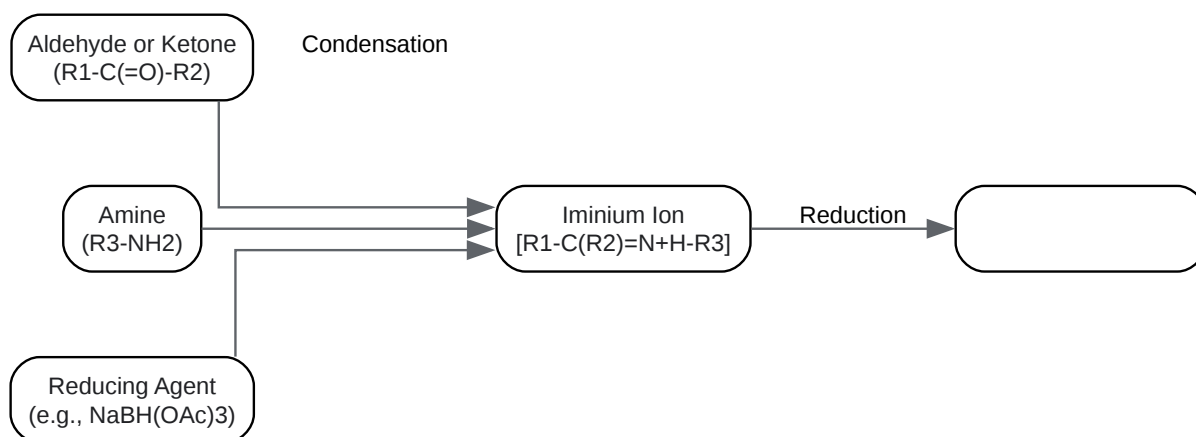

[Click to download full resolution via product page](#)

Caption: Generalized workflow of a reductive amination reaction.

Sodium Cyanoborohydride (NaBH₃CN)

Sodium cyanoborohydride is another selective reducing agent frequently used in reductive aminations.^{[6][7]} It is particularly effective under mildly acidic conditions, which facilitate the formation of the iminium ion.^[8] A notable advantage of NaBH₃CN is its stability in protic solvents like methanol. However, a significant drawback is the generation of toxic cyanide byproducts, which necessitates careful handling and waste disposal.

Catalytic Hydrogenation

Catalytic hydrogenation offers a greener and more atom-economical approach to reductive amination.^{[12][16]} This method employs molecular hydrogen (H₂) as the reducing agent in the presence of a metal catalyst, such as palladium on carbon (Pd/C), platinum on carbon (Pt/C), or Raney nickel.^{[3][16]} The reaction is typically carried out under pressure and can be adapted for continuous-flow systems, making it suitable for large-scale synthesis.^[17]

Comparative Analysis of Common Reducing Agents

Reducing Agent	Advantages	Disadvantages	Typical Solvents
Sodium Triacetoxyborohydride (NaBH(OAc) ₃)	Mild and selective, wide substrate scope, good for one-pot reactions.[11]	Moisture sensitive, relatively expensive.	DCE, DCM, THF.
Sodium Cyanoborohydride (NaBH ₃ CN)	Effective in protic solvents, stable to water.	Highly toxic byproducts.	Methanol, Ethanol.
Catalytic Hydrogenation (H ₂ /Catalyst)	Atom economical, environmentally friendly, scalable.[16]	Requires specialized high-pressure equipment, potential for over-reduction.	Methanol, Ethanol, Ethyl Acetate.
Sodium Borohydride (NaBH ₄)	Inexpensive and readily available.	Less selective, can reduce the starting carbonyl.[14]	Methanol, Ethanol.

Experimental Protocols

Protocol 1: One-Pot Synthesis of N-Substituted Piperazines using Sodium Triacetoxyborohydride

This protocol describes a general procedure for the synthesis of an N-substituted piperazine from a primary amine and a diketone precursor.

Materials:

- Appropriate primary amine (1.0 eq)
- 1,4-Diketone (1.05 eq)
- Sodium triacetoxyborohydride (NaBH(OAc)₃) (2.5 eq)
- 1,2-Dichloroethane (DCE)
- Acetic acid (catalytic amount, optional)

- Saturated aqueous sodium bicarbonate (NaHCO_3) solution
- Brine
- Anhydrous magnesium sulfate (MgSO_4) or sodium sulfate (Na_2SO_4)
- Standard laboratory glassware and magnetic stirrer

Procedure:

- To a round-bottom flask equipped with a magnetic stir bar, add the primary amine and the 1,4-diketone.
- Dissolve the starting materials in an appropriate volume of DCE (to make an approximately 0.1-0.2 M solution).
- If the amine is a salt (e.g., hydrochloride), add one equivalent of a non-nucleophilic base (e.g., triethylamine) to liberate the free amine.
- Slowly add sodium triacetoxyborohydride to the stirring solution at room temperature. The addition may be exothermic.
- If the reaction is sluggish, a catalytic amount of acetic acid can be added to facilitate iminium ion formation.
- Stir the reaction mixture at room temperature for 12-24 hours. Monitor the reaction progress by Thin Layer Chromatography (TLC) or Liquid Chromatography-Mass Spectrometry (LC-MS).
- Upon completion, carefully quench the reaction by the slow addition of saturated aqueous NaHCO_3 solution until gas evolution ceases.
- Transfer the mixture to a separatory funnel and extract the aqueous layer with an organic solvent such as dichloromethane or ethyl acetate (3 x volume).
- Combine the organic layers, wash with brine, dry over anhydrous MgSO_4 or Na_2SO_4 , filter, and concentrate under reduced pressure.

- The crude product can be purified by column chromatography on silica gel.

Diagram: Experimental Workflow for One-Pot Piperazine Synthesis

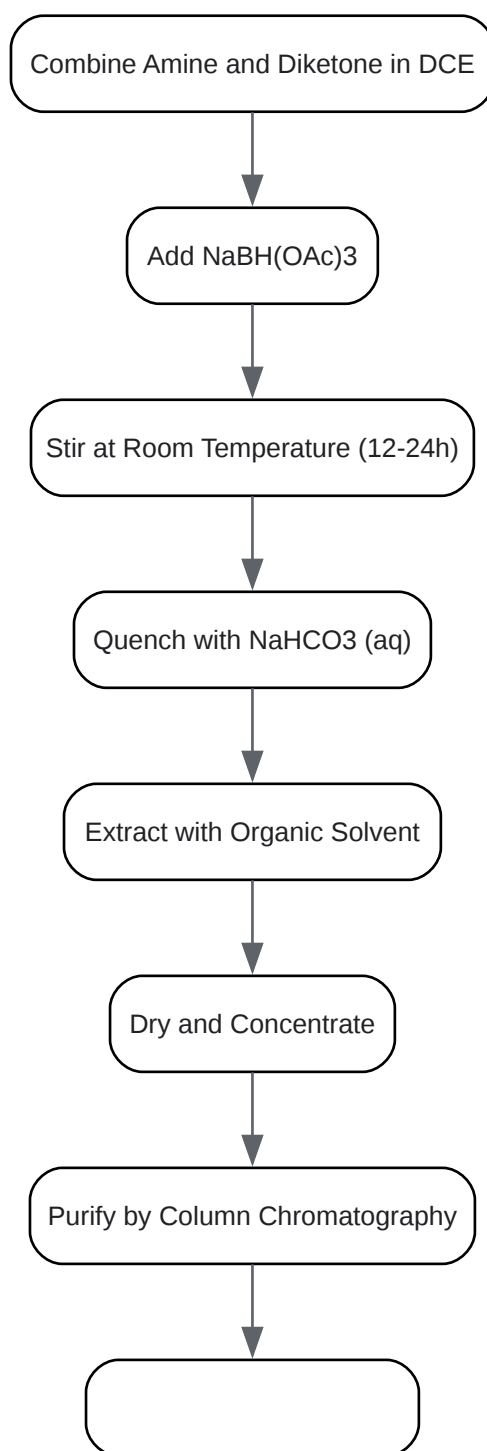

[Click to download full resolution via product page](#)

Caption: Step-by-step workflow for one-pot piperazine synthesis.

Protocol 2: Synthesis of Piperazine via Catalytic Hydrogenation

This protocol outlines a general procedure for the synthesis of piperazine from a suitable precursor using catalytic hydrogenation.

Materials:

- Dioxime precursor (1.0 eq)^[3]
- Palladium on carbon (5% Pd/C, 5-10 mol%)
- Methanol or Ethanol
- High-pressure hydrogenation vessel (e.g., Parr shaker)
- Hydrogen gas source
- Filtration apparatus (e.g., Celite pad)

Procedure:

- In a high-pressure reaction vessel, dissolve the dioxime precursor in methanol or ethanol.
- Carefully add the Pd/C catalyst to the solution under an inert atmosphere (e.g., nitrogen or argon).
- Seal the reaction vessel and purge it several times with hydrogen gas.
- Pressurize the vessel with hydrogen gas to the desired pressure (e.g., 50-100 psi).
- Stir the reaction mixture vigorously at room temperature or with gentle heating (e.g., 40-50 °C) for 6-24 hours.
- Monitor the reaction progress by observing the hydrogen uptake or by analyzing aliquots via TLC or LC-MS.

- Once the reaction is complete, carefully vent the excess hydrogen gas and purge the vessel with an inert gas.
- Filter the reaction mixture through a pad of Celite to remove the catalyst. Wash the filter cake with the reaction solvent.
- Combine the filtrate and washings, and concentrate under reduced pressure to obtain the crude piperazine product.
- Further purification can be achieved by distillation or recrystallization.

Conclusion

Reductive amination is a robust and highly adaptable methodology for the synthesis of piperazines, a critical scaffold in modern drug discovery. The choice between different reducing agents and protocols allows for the fine-tuning of reaction conditions to accommodate a wide range of substrates and functional groups. By understanding the underlying principles and having access to detailed experimental protocols, researchers can effectively leverage reductive amination to construct diverse libraries of piperazine derivatives for the development of new therapeutic agents.

References

- Recent Advances in Piperazine Synthesis. (2017). Vertex AI Search.
- Piperazine Derivatives: A Privileged Scaffold in Modern Synthesis and Medicinal Chemistry. (2026). Vertex AI Search.
- Recently Adopted Synthetic Protocols for Piperazines: A Review. (2024). Bentham Science.
- Reductive Amination by Continuous-Flow Hydrogenation: Direct and Scalable Synthesis of a Benzylpiperazine. (2025).
- Reductive Amin
- Recent advances in the synthesis of piperazine based ligands and metal complexes and their applications. Dalton Transactions (RSC Publishing).
- The medicinal chemistry of piperazines: A review. (2024). PubMed.
- Building Up a Piperazine Ring from a Primary Amino Group via Catalytic Reductive Cycliz
- Method for the preparation of piperazine and its derivatives.
- Sodium triacetoxyborohydride. Organic Chemistry Portal.
- Design and Synthesis of Piperazine-Based Compounds Conjugated to Humanized Ferritin as Delivery System of siRNA in Cancer Cells. (2021). PMC.

- Sodium Triacetoxyborohydride. Sigma-Aldrich.
- Reductive amination route for selective N-monosubstitution. Piperazine...
- Synthetic Approaches to Piperazine-Containing Drugs Approved by FDA in the Period of 2011–2023. (2023). MDPI.
- Reductive Amination, and How It Works. (2017). Master Organic Chemistry.
- A Review on the Use of Sodium Triacetoxyborohydride in the Reductive Amination of Ketones and Aldehydes. Sciencemadness.org.
- Green Catalytic Synthesis of Ethylenediamine from Ethylene Glycol and Monoethanolamine: A Review. (2024).
- A kind of preparation method of ethylene glycol Piperazine Synthesis by Gas-Solid Catalyzed and catalyst.
- Co-Catalyzed Synthesis of Primary Amines via Reductive Amination employing Hydrogen under very mild Conditions. Wiley Online Library.
- Application Notes & Protocols: One-Pot Synthesis of Piperazines
- Reductive Amination - Common Conditions.
- Catalyst and amination process for the synthesis of piperazine
- Reductive Amination by Continuous-Flow Hydrogenation: Direct and Scalable Synthesis of a Benzylpiperazine. Thieme E-Books & E-Journals.
- Methods for the catalytic synthesis of piperazine.
- Simplified Procedure for General Synthesis of Monosubstituted Piperazines—From a Batch Reaction Vessel to a Flow (Microwave) Reactor. (2020). PMC.
- Reductive Amination of Aldehydes and Ketones with Sodium Triacetoxyborohydride. Studies on Direct and Indirect Reductive Amination Procedures.
- A Comparative Analysis of Piperazine Synthesis Methods for Researchers and Drug Development Professionals. Benchchem.
- Reductive amination of ketones/aldehydes with amines using $\text{BH}_3\text{N}(\text{C}_2\text{H}_5)_3$ as a reductant.
- Aldehydes and Ketones to Amines. (2024). Chemistry Steps.
- Birch Reduction of Aromatic Rings. (2019). Master Organic Chemistry.
- Piperazine. Wikipedia.
- Design and Synthesis of Piperazine-Based Compounds Conjugated to Humanized Ferritin as Delivery System of siRNA in Cancer Cells. (2021).
- Reductive amin
- Synthesis of Novel Piperazine-Containing Compounds: A Technical Guide for Drug Discovery Professionals. Benchchem.
- Recent Advances in the Synthesis of Piperazines: Focus on C–H Functionaliz
- Synthesis of Piperazines by C-H Functionaliz

Need Custom Synthesis?

BenchChem offers custom synthesis for rare earth carbides and specific isotopic labeling.

Email: info@benchchem.com or [Request Quote Online](#).

Sources

- [1. Recent advances in the synthesis of piperazine based ligands and metal complexes and their applications - Dalton Transactions \(RSC Publishing\) \[pubs.rsc.org\]](#)
- [2. The medicinal chemistry of piperazines: A review - PubMed \[pubmed.ncbi.nlm.nih.gov\]](#)
- [3. Building Up a Piperazine Ring from a Primary Amino Group via Catalytic Reductive Cyclization of Dioximes - PMC \[pmc.ncbi.nlm.nih.gov\]](#)
- [4. Piperazine Derivatives: A Privileged Scaffold in Modern Synthesis and Medicinal Chemistry - PMC \[pmc.ncbi.nlm.nih.gov\]](#)
- [5. mdpi.com \[mdpi.com\]](#)
- [6. masterorganicchemistry.com \[masterorganicchemistry.com\]](#)
- [7. Reductive Amination - Chemistry Steps \[chemistrysteps.com\]](#)
- [8. Aldehydes and Ketones to Amines - Chemistry Steps \[chemistrysteps.com\]](#)
- [9. researchgate.net \[researchgate.net\]](#)
- [10. pdf.benchchem.com \[pdf.benchchem.com\]](#)
- [11. Sodium triacetoxyborohydride \[organic-chemistry.org\]](#)
- [12. Reductive amination - Wikipedia \[en.wikipedia.org\]](#)
- [13. pubs.acs.org \[pubs.acs.org\]](#)
- [14. sciencemadness.org \[sciencemadness.org\]](#)
- [15. Design and Synthesis of Piperazine-Based Compounds Conjugated to Humanized Ferritin as Delivery System of siRNA in Cancer Cells - PMC \[pmc.ncbi.nlm.nih.gov\]](#)
- [16. researchgate.net \[researchgate.net\]](#)
- [17. Thieme E-Books & E-Journals - \[thieme-connect.com\]](#)
- To cite this document: BenchChem. [Application Notes and Protocols for the Reductive Amination Synthesis of Piperazines]. BenchChem, [2026]. [Online PDF]. Available at:

[\[https://www.benchchem.com/product/b1629644/docs#application-notes-and-protocols-for-the-reductive-amination-synthesis-of-piperazines\]](https://www.benchchem.com/product/b1629644/docs#application-notes-and-protocols-for-the-reductive-amination-synthesis-of-piperazines)

Disclaimer & Data Validity:

The information provided in this document is for Research Use Only (RUO) and is strictly not intended for diagnostic or therapeutic procedures. While BenchChem strives to provide accurate protocols, we make no warranties, express or implied, regarding the fitness of this product for every specific experimental setup.

Technical Support: The protocols provided are for reference purposes. Unsure if this reagent suits your experiment?

Need Industrial/Bulk Grade? [Request Custom Synthesis Quote](#)

BenchChem

Our mission is to be the trusted global source of essential and advanced chemicals, empowering scientists and researchers to drive progress in science and industry.

Contact

Address: 3281 E Guasti Rd
Ontario, CA 91761, United States
Phone: (601) 213-4426
Email: info@benchchem.com

[Contact our Ph.D. Support Team for a compatibility check](#)