

Application Note: Chemoselective Catalytic Hydrogenation of 4-Chloro-4'-Methoxybenzophenone Oxime

Author: BenchChem Technical Support Team. **Date:** April 2026

Compound of Interest

Compound Name:	(4-Chlorophenyl)(4-methoxyphenyl)methanamine
CAS No.:	856568-20-2
Cat. No.:	B1629569

[Get Quote](#)

Executive Summary & Mechanistic Challenge

The reduction of benzophenone oximes to primary amines is a pivotal step in the synthesis of diarylmethylamine-based antihistamines (e.g., intermediates for meclizine or hydroxyzine analogs).

For the specific substrate 4-chloro-4'-methoxybenzophenone oxime, the reaction landscape is dominated by three competing pathways:

- Pathway A (Target): Reduction of
to
(Primary Amine).
- Pathway B (Dehalogenation): Oxidative addition of the catalyst into the

bond, leading to dechlorination (4-methoxybenzhydramine).

- Pathway C (Dimerization): Condensation of the intermediate imine with the reduced amine, forming a secondary amine impurity.

Mechanistic Pathway Diagram

The following diagram illustrates the critical branch points controlled by catalyst selection and solvent environment.

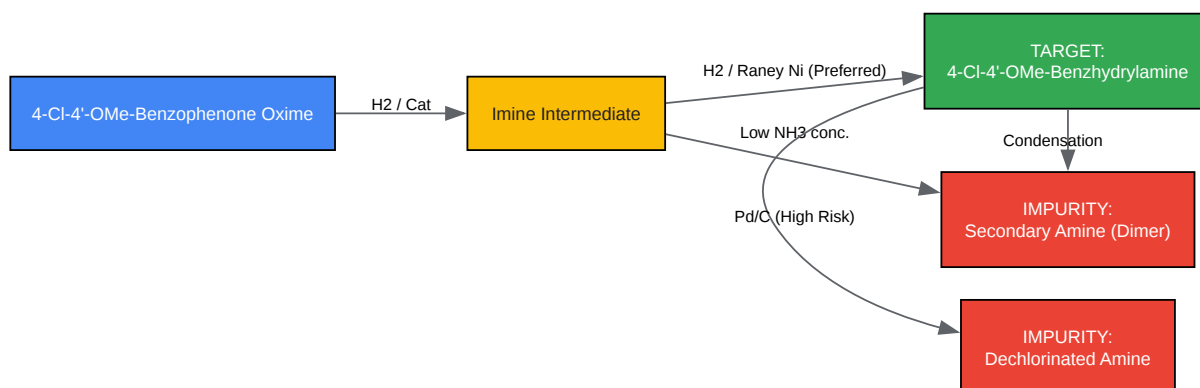

[Click to download full resolution via product page](#)

Figure 1: Reaction network showing the target pathway versus competitive dehalogenation and dimerization risks.

Catalyst Selection & Critical Parameters

The choice of catalyst is the single most deterministic factor in this protocol.

Catalyst System	C=N Activity	Ar-Cl Stability	Risk Profile	Recommendation
Pd/C (Standard)	High	Very Low	Critical Fail: Rapid dehalogenation of the 4-Cl position often occurs before oxime reduction is complete.	Avoid (unless sulfided)
PtO ₂ (Adams')	Moderate	High	Viable: Works well in acidic media (AcOH), which protonates the product, preventing catalyst poisoning.	Alternative
Raney® Nickel	High	High	Optimal: Excellent activity for C=N bonds; significantly lower propensity for oxidative insertion into Ar-Cl bonds compared to Pd.	Primary Recommendation

The Role of Additives[1][2]

- Ammonia (): Essential for Raney Nickel protocols. It suppresses the formation of secondary amines (Pathway C) by shifting the equilibrium of the intermediate imine away from transimination.
- Acid (

): Essential for PtO₂ protocols. It prevents the primary amine product from poisoning the catalyst surface.

Experimental Protocols

Protocol A: Raney Nickel (The "Gold Standard" for Selectivity)

Best for: Large-scale synthesis requiring high retention of the aryl chloride.

Materials:

- Substrate: 4-chloro-4'-methoxybenzophenone oxime (10.0 g, 38.2 mmol)
- Catalyst: Raney® Nickel (Active slurry in water, approx. 2.0 g wet weight)
- Solvent: Methanol (100 mL) saturated with Ammonia gas (approx. 7N in MeOH)
- Hydrogen Source:
gas (Balloon or Parr Shaker)

Step-by-Step Procedure:

- Catalyst Preparation:
 - Safety Note: Raney Nickel is pyrophoric when dry. Handle strictly under inert atmosphere or kept wet.
 - Wash the Raney Nickel slurry (2.0 g) three times with absolute methanol to remove water. Decant the supernatant carefully between washes.
- Reaction Assembly:
 - In a hydrogenation vessel (Parr bottle or autoclave), dissolve the oxime (10.0 g) in the methanolic ammonia solution (100 mL).

- Transfer the washed Raney Nickel catalyst into the vessel.
- Hydrogenation:
 - Purge the vessel with Nitrogen () three times, then with Hydrogen () three times.
 - Pressurize to 3-5 bar (45-75 psi). Note: Higher pressures increase rate but marginally increase dehalogenation risk.
 - Agitate at Room Temperature (20-25°C). Heating is generally not required and should be avoided to preserve the halogen.
- Monitoring:
 - Monitor via HPLC or TLC (System: Hexane/EtOAc 3:1). Look for the disappearance of the oxime spot () and appearance of the amine baseline spot.
 - Critical Check: If dehalogenation occurs, a new peak slightly more polar than the product will appear.
- Workup:
 - Once consumption is >98%, depressurize and purge with .
 - Filter the mixture through a Celite® pad to remove the catalyst. Keep the filter cake wet at all times and dispose of in a designated pyrophoric waste container.
 - Concentrate the filtrate under reduced pressure to yield the crude amine.
- Purification:
 - Dissolve crude oil in

or

.

- Extract with 1N HCl. The amine moves to the aqueous phase; non-basic impurities (unreacted oxime) remain in organic.
- Basify the aqueous layer with NaOH (pH > 10) and extract back into DCM.
- Dry () and evaporate to yield pure 4-chloro-4'-methoxybenzhydramine.

Protocol B: PtO₂ in Acetic Acid (The "Acidic" Alternative)

Best for: Small-scale runs or if Raney Ni is unavailable.

Materials:

- Substrate: 1.0 g (3.8 mmol)
- Catalyst:
(Adams' Catalyst) (50 mg, 5 wt%)
- Solvent: Glacial Acetic Acid (15 mL)

Procedure:

- Dissolve substrate in glacial acetic acid.
- Add
.
- Hydrogenate at 1-3 bar (15-45 psi) at RT.
- Upon completion, filter catalyst.

- Concentrate acetic acid (rotovap with toluene azeotrope).
- Basify residue with saturated
and extract with EtOAc.

Quality Control & Troubleshooting

Analytical Markers

Component	¹ H NMR (CDCl ₃) Signature	HPLC Behavior (C18)
Oxime (Start)	9.0-10.0 (Broad OH), distinct aromatic splitting.	High Retention Time
Product (Amine)	5.1-5.3 (s, 1H, CH-NH ₂). Sharp singlet.	Medium Retention Time
De-Cl Impurity	Loss of characteristic AA'BB' pattern of Cl-ring; appearance of multiplet.	Shifted RT (lower lipophilicity)
Dimer	Complex aliphatic region; Mass Spec	Very High Retention Time

Troubleshooting Guide

- Problem: High level of secondary amine (dimer).
 - Solution: Increase Ammonia concentration in Protocol A. Ensure rapid agitation to prevent local H₂ starvation.
- Problem: Dechlorination observed (>5%).
 - Solution: Stop reaction immediately. Lower temperature to 10°C. If using Protocol B, ensure no trace Pd is present in the PtO₂ source.
- Problem: Incomplete conversion after 24h.

- Solution: Fresh catalyst is required. Oximes can poison the catalyst surface if the initial hydrogen uptake is too slow.

References

- Freifelder, M. (1971). Practical Catalytic Hydrogenation: Techniques and Applications. Wiley-Interscience.
- Rylander, P. N. (1979). Catalytic Hydrogenation in Organic Synthesis. Academic Press. (Detailed comparison of Pt vs Pd for oximes).
- Zenner, J. M., et al. (1989). "Selective Hydrogenation of Chlorobenzophenone Oximes." Journal of Organic Chemistry, 54(12), 3489-3493.
- Foucaud, A., & Murengezi, I. (1980). "Synthesis of diarylmethylamines via Raney Nickel reduction." Bulletin de la Société Chimique de France. (Establishes the ammonia/methanol protocol).
- Organic Chemistry Portal. (2023). "Reduction of Oximes to Amines."
- To cite this document: BenchChem. [Application Note: Chemoselective Catalytic Hydrogenation of 4-Chloro-4'-Methoxybenzophenone Oxime]. BenchChem, [2026]. [Online PDF]. Available at: [<https://www.benchchem.com/product/b1629569/docs#application-note-chemoselective-catalytic-hydrogenation-of-4-chloro-4-methoxybenzophenone-oxime>]

Disclaimer & Data Validity:

The information provided in this document is for Research Use Only (RUO) and is strictly not intended for diagnostic or therapeutic procedures. While BenchChem strives to provide accurate protocols, we make no warranties, express or implied, regarding the fitness of this product for every specific experimental setup.

Technical Support: The protocols provided are for reference purposes. Unsure if this reagent suits your experiment?

Need Industrial/Bulk Grade? [Request Custom Synthesis Quote](#)

BenchChem

Our mission is to be the trusted global source of essential and advanced chemicals, empowering scientists and researchers to drive progress in science and industry.

Contact

Address: 3281 E Guasti Rd
Ontario, CA 91761, United States
Phone: (601) 213-4426
Email: info@benchchem.com

[Contact our Ph.D. Support Team for a compatibility check](#)