

# Technical Support: N-Boc Protection of (S)-Amphetamine Derivatives[1][2]

**Author:** BenchChem Technical Support Team. **Date:** May 2026

## Compound of Interest

Compound Name: *N*-Boc (S)-Amphetamine

CAS No.: 293305-71-2

Cat. No.: B1628289

[Get Quote](#)

Ticket ID: BOC-AMPH-001 Subject: Overcoming Steric Hindrance & Preventing Racemization in

-Methyl Benzyl Amine Derivatives Assigned Specialist: Senior Application Scientist, Synthesis Division[1]

## Executive Summary & Problem Analysis

You are experiencing kinetic stalling or low conversion during the protection of (S)-amphetamine (and its derivatives) with di-tert-butyl dicarbonate (

).[1]

The Root Cause: While (S)-amphetamine is a primary amine, the

-methyl group adjacent to the nitrogen creates a steric clash that impedes the nucleophilic attack on the bulky

electrophile.[1] Furthermore, the benzylic position of the

-proton increases its acidity (

), introducing a critical risk of racemization if thermodynamic forcing (high heat/strong base) is applied to overcome the kinetic barrier.[1]

This guide provides a validated "Hard Protocol" to accelerate the reaction without compromising stereochemical integrity.

## Experimental Protocols

### Method A: The "Standard" Protocol (Baseline)

Use this for initial screening.[1] If conversion is

after 6 hours, switch to Method B.

- Reagents: (S)-Amphetamine (1.0 eq),  
(1.1 eq),  
(1.5 eq).[1]
- Solvent: DCM (Dichloromethane) or THF (0.2 M).[1]
- Conditions: Room Temperature (RT), 4–12 hours.[1]

### Method B: The "Catalyzed" Protocol (Recommended for Hindered Substrates)

Designed to overcome steric hindrance using Lewis Acid catalysis rather than thermal forcing.

| Component  | Specification              | Function  |
|------------|----------------------------|---|
| Substrate  | (S)-Amphetamine derivative | Limiting reagent.[1]  |
| Reagent    | (1.2 – 1.5 eq)             | Slight excess drives equilibrium.[1]  |
| Catalyst   | Iodine ( ) (5 mol%)        | Lewis Acid activator. Activates the carbonyl of without basicity, preventing racemization.[1] |
| Solvent    | DCM or Acetonitrile (MeCN) | MeCN accelerates polar transition states.[1]  |
| Conditions | RT, 2–4 hours              | Fast kinetics due to activation. [1]  |

#### Step-by-Step Workflow (Method B):

- Dissolve (S)-amphetamine (1.0 mmol) in DCM (5 mL).
- Add (1.2 mmol).
- Add (0.05 mmol, ~12 mg). The solution may darken temporarily.
- Stir at RT.[1][2] Monitor by TLC/LC-MS. The reaction typically completes in <4 hours.[1]
- Quench: Add saturated aqueous (sodium thiosulfate) to reduce iodine (color disappears).
- Workup: Extract with DCM, wash with dilute HCl (0.5 M) to remove unreacted amine, then brine.

## Troubleshooting Center (Q&A)

### Issue 1: Reaction Stalls at 60-70% Conversion

User Question: "I'm using standard conditions ( ), but the reaction stops progressing. Should I heat it to reflux?"

Technical Response: Do NOT reflux in basic conditions. Heating a benzylic amine with a base like Triethylamine ( ) increases the risk of deprotonating the chiral center ( -proton), leading to racemization.[1]

- Solution 1 (The Cleanest): Switch to Method B (Iodine catalysis).[1] It works at room temperature.[1][3][4][5]
- Solution 2 (The Solvent Switch): If you lack iodine, switch solvent to Methanol (MeOH).[1] Hydrogen bonding in protic solvents can activate and stabilize the transition state, often pushing conversion to completion without heat.[1]

### Issue 2: Racemization of the (S)-Isomer

User Question: "My chiral HPLC shows an enantiomeric excess (ee) drop from 99% to 92%. Why?"

Technical Response: This usually indicates "Over-Catalysis" or "Base-Induced Tautomerization."[1]

- Check DMAP Usage: Did you use DMAP (4-Dimethylaminopyridine)? While DMAP is a powerful catalyst, it forms an N-acylpyridinium salt that is highly electrophilic but can also act as a base.[1] Excess DMAP (>10 mol%) can shuttle protons and racemize sensitive centers. [1] Limit DMAP to 1-5 mol%.
- Check Workup: Did you wash with strong base? Prolonged exposure to high pH during workup can cause racemization.[1] Keep workup washes neutral or mildly acidic.[1]

## Issue 3: Removing Excess

User Question: "I used 1.5 equivalents of

to force the reaction. Now I can't get rid of it. It's an oil that won't crystallize."[\[1\]](#)

Technical Response:

is lipophilic and difficult to remove by column chromatography if it co-elutes with your product.

[\[1\]](#)

- The "Scavenger" Protocol:
  - At the end of the reaction, add Imidazole (0.5 eq relative to excess ) or N,N-Dimethylethylenediamine (DMEDA).
  - Stir for 30 minutes. This converts excess into a water-soluble urea or Boc-imidazole species.[\[1\]](#)
  - Wash the organic layer with 0.5 M HCl.[\[1\]](#) The scavenger-Boc adduct will partition into the aqueous phase, leaving pure product in the organic layer.[\[1\]](#)

## Visualizing the Logic

### Diagram 1: Troubleshooting Decision Matrix

Caption: Decision flow for optimizing hindered amine protection while preserving chirality.

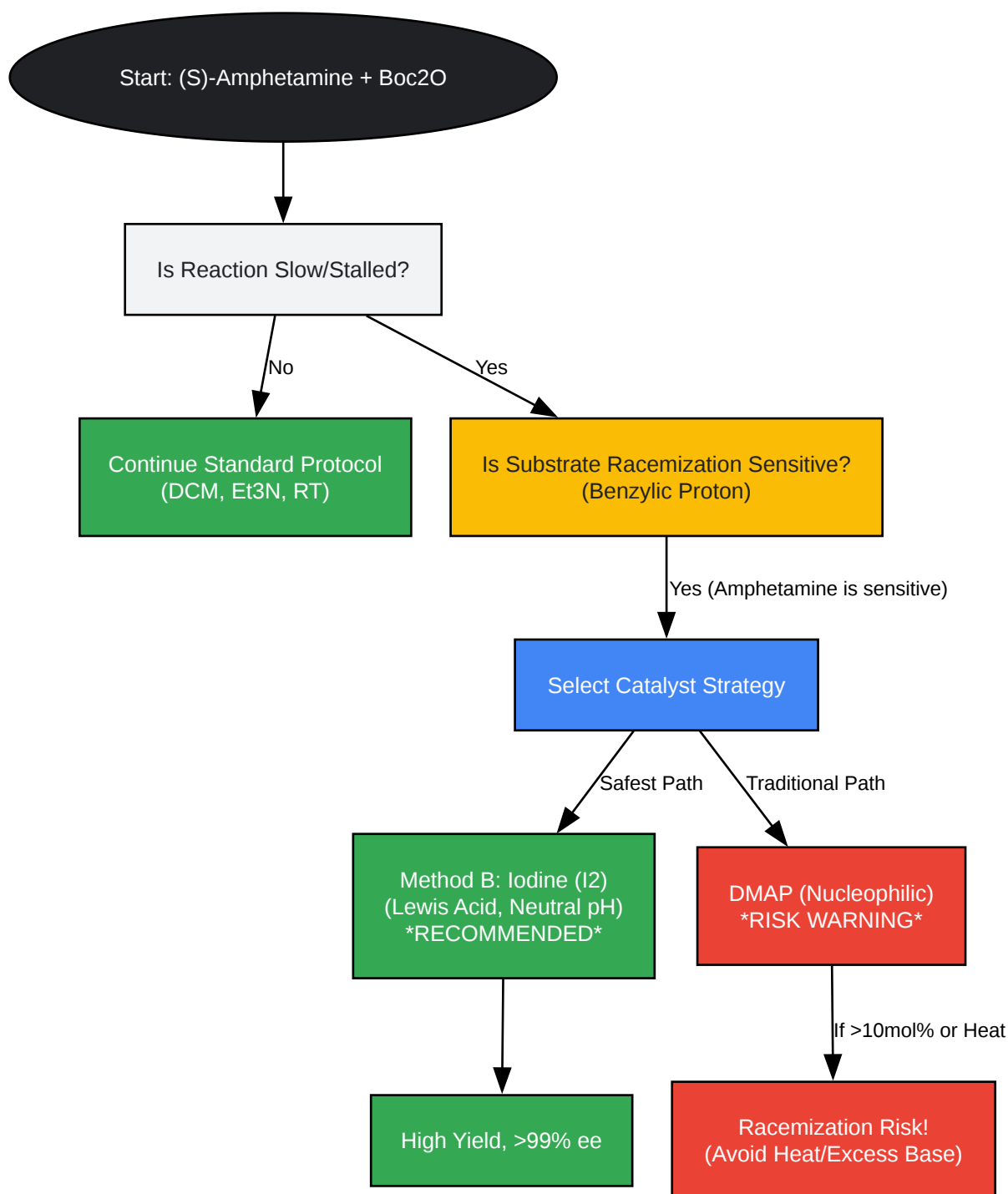

[Click to download full resolution via product page](#)

[1]

## Diagram 2: Steric Mechanism & Activation

Caption: Comparison of standard nucleophilic attack vs. Iodine-activated pathway reducing steric barrier.

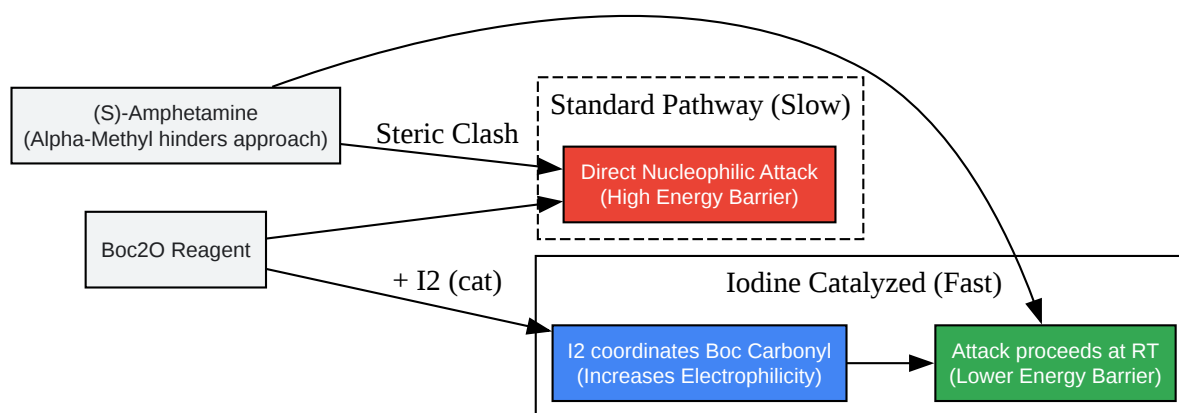

[Click to download full resolution via product page](#)

## References

- Iodine Catalysis: Phukan, P. (2004).[1] Iodine as an extremely powerful catalyst for the acetylation of alcohols under solvent-free conditions.[1] *Tetrahedron Letters*, 45(24), 4785-4787.[1] (Applied here to Boc protection context based on Lewis Acid activation principles).
- Lewis Acid Catalysis (General): Chakraborti, A. K., et al. (2006).[1][3] Perchloric acid adsorbed on silica-gel (HClO<sub>4</sub>-SiO<sub>2</sub>) as a new, highly efficient, inexpensive and reusable catalyst for N-tert-butoxycarbonylation of amines.[1][3] *Organic & Biomolecular Chemistry*, 4, 2769-2771.[1][3] [Link](#)
- Racemization Risks: Wuts, P. G. M., & Greene, T. W. (2006).[1] *Greene's Protective Groups in Organic Synthesis* (4th ed.).[1] Wiley-Interscience.[1] (Standard text on protection group stability and racemization).
- Workup Scavenging: Kotha, S., et al. (2002).[1] Recent applications of the Suzuki-Miyaura cross-coupling reaction in organic synthesis. *Tetrahedron*, 58(48), 9633-9695.[1] (Refers to imidazole usage for reagent scavenging).[1][4][6][7]

- Ionic Liquids: Sarkar, A., et al. (2011).[1][3] 1-Alkyl-3-methylimidazolium cation based ionic liquids efficiently catalyze N-tert-butyloxycarbonylation of amines.[1][3] Journal of Organic Chemistry, 76(17), 7132-7140.[1] [Link](#)[1]

### Need Custom Synthesis?

BenchChem offers custom synthesis for rare earth carbides and specific isotopic labeling.

Email: [info@benchchem.com](mailto:info@benchchem.com) or [Request Quote Online](#).

## Sources

- 1. [csclub.uwaterloo.ca](http://csclub.uwaterloo.ca) [[csclub.uwaterloo.ca](http://csclub.uwaterloo.ca)]
- 2. [scispace.com](http://scispace.com) [[scispace.com](http://scispace.com)]
- 3. [Boc-Protected Amino Groups](http://Boc-Protected Amino Groups) [[organic-chemistry.org](http://organic-chemistry.org)]
- 4. [researchgate.net](http://researchgate.net) [[researchgate.net](http://researchgate.net)]
- 5. [researchgate.net](http://researchgate.net) [[researchgate.net](http://researchgate.net)]
- 6. [reddit.com](http://reddit.com) [[reddit.com](http://reddit.com)]
- 7. [reddit.com](http://reddit.com) [[reddit.com](http://reddit.com)]
- To cite this document: BenchChem. [Technical Support: N-Boc Protection of (S)-Amphetamine Derivatives[1][2]]. BenchChem, [2026]. [Online PDF]. Available at: [<https://www.benchchem.com/product/b1628289/docs#technical-support-n-boc-protection-of-s-amphetamine-derivatives-1-2>]

---

### Disclaimer & Data Validity:

The information provided in this document is for Research Use Only (RUO) and is strictly not intended for diagnostic or therapeutic procedures. While BenchChem strives to provide accurate protocols, we make no warranties, express or implied, regarding the fitness of this product for every specific experimental setup.

**Technical Support:** The protocols provided are for reference purposes. Unsure if this reagent suits your experiment?

**Need Industrial/Bulk Grade?** [Request Custom Synthesis Quote](#)

# BenchChem

Our mission is to be the trusted global source of essential and advanced chemicals, empowering scientists and researchers to drive progress in science and industry.

## Contact

Address: 3281 E Guasti Rd  
Ontario, CA 91761, United States  
Phone: (601) 213-4426  
Email: [info@benchchem.com](mailto:info@benchchem.com)

[Contact our Ph.D. Support Team for a compatibility check](#)