

Technical Guide: Comparative Strategies for Mono-Protected Diamine Synthesis

Author: BenchChem Technical Support Team. **Date:** May 2026

Compound of Interest

Compound Name: *N-Triyl-1,2-ethanediamine hydrobromide*
CAS No.: 389064-43-1
Cat. No.: B1628918

[Get Quote](#)

Executive Summary: The Symmetry Challenge

The selective mono-protection of symmetrical diamines (e.g., ethylenediamine, piperazine, trans-1,4-diaminocyclohexane) is a foundational yet deceptive challenge in medicinal chemistry. The core difficulty lies in the statistical probability of reaction. In a standard bimolecular reaction with a 1:1 stoichiometry, the second amine group often remains nucleophilic (or becomes more nucleophilic due to electronic effects), leading to a mixture of:

- Unreacted Diamine (Starting Material)
- Mono-protected Product (Target)
- Di-protected Byproduct (Impurity)

This guide objectively compares three distinct synthetic strategies—Statistical, Thermodynamic (Acid-Salt), and Kinetic (Flow)—to provide actionable routes for high-yield synthesis of mono-protected diamines (MPDs).

Strategic Comparison of Methodologies

The following table synthesizes performance metrics from key literature sources, comparing yield, selectivity, and scalability.

| Methodology | Mechanism of Control | Typical Yield (Mono) | Selectivity (Mono:Di) | Scalability | Key Limitation |
|----------------------|------------------------------|------------------------------|--------------------------|-------------|---|
| Statistical / Excess | Concentration (Le Chatelier) | >90% (based on electrophile) | High (if >5 eq. diamine) | Low | Wasteful; requires massive excess of diamine and tedious recovery. |
| Acid-Salt Control | pH / pKa Differentiation | 66% – 87% | High (>95:5) | High | Requires precise stoichiometry of acid; solubility issues in some solvents. |
| Continuous Flow | Kinetic / Mixing | 45% – 91% | Tunable | Very High | Requires flow reactor hardware; optimization of residence time essential. |
| Selective Reagents | Steric / Electronic | 70% – 95% | High | Moderate | Reagents (e.g., phenyl carbonates) may be expensive or require synthesis. |

Deep Dive: Thermodynamic Control (The Acid-Salt Method)

Mechanism & Rationale

This method relies on the significant difference in pKa between the first and second protonation states of a diamine. By adding exactly 1 equivalent of acid (HCl, TFA, or generated in situ via TMSCl), one amine is protonated (deactivated), while the other remains a free base (reactive).

- Why it works: Coulombic repulsion makes the protonation of the second amine less favorable, but more importantly, the mono-protonated species () reacts with the electrophile (e.g.,) only at the neutral site.
- Literature Validation: Lee et al. (2007) and Servín et al. (2017) demonstrated yields of ~87% for ethylenediamine and 66% for trans-cyclohexane-1,2-diamine using this method.

Visualization: Acid-Salt Selectivity Pathway

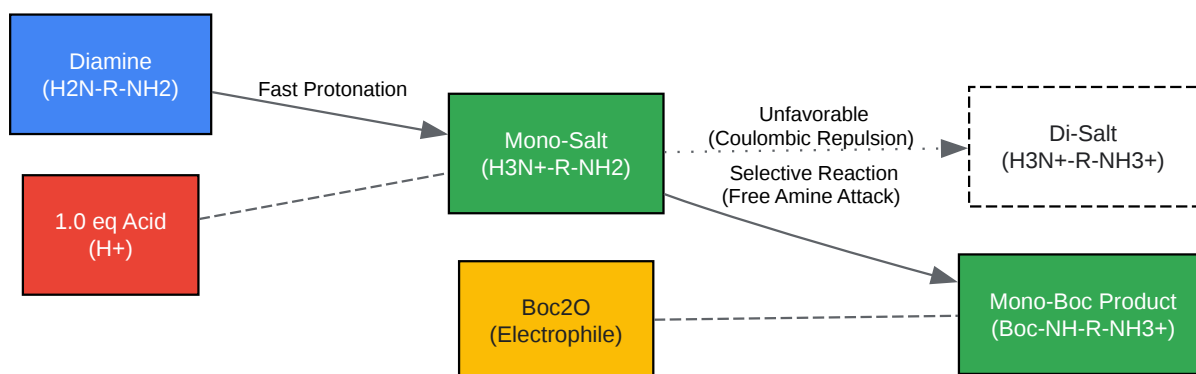

[Click to download full resolution via product page](#)

Caption: The stoichiometry of 1.0 eq acid ensures the Mono-Salt is the dominant species, leaving exactly one nucleophilic site available for the electrophile.

Experimental Protocol (Batch)

Target: N-Boc-trans-cyclohexane-1,2-diamine (1a) Reference: Adapted from Servín et al. (2017).

- Salt Formation: Dissolve (1R,2R)-cyclohexane-1,2-diamine (1.0 g, 8.7 mmol) in anhydrous methanol (10 mL) at 0 °C.
- Acid Addition: Dropwise add trimethylsilyl chloride (TMSCl) (1.1 mL, 8.7 mmol, 1.0 eq).
 - Note: TMSCl reacts with methanol to generate HCl in situ and methoxy-trimethylsilane. This avoids handling hygroscopic HCl salts.
- Equilibration: Stir at room temperature for 30 min. A white precipitate (mono-hydrochloride salt) may form.
- Protection: Add di-tert-butyl dicarbonate () (1.9 g, 8.7 mmol, 1.0 eq) dissolved in methanol (3 mL).
- Reaction: Stir at room temperature for 1–2 hours.
- Workup:
 - Dilute with water (50 mL).
 - Wash with diethyl ether (2 x 50 mL) to remove any di-protected byproduct (which is neutral and organic-soluble).
 - Basify the aqueous layer to pH >12 using 2N NaOH.^[1]
 - Extract the free mono-protected amine into dichloromethane (3 x 50 mL).
- Result: Dry organic layers (ngcontent-ng-c4120160419="" _nghost-ng-c3115686525="" class="inline ng-star-inserted">) and concentrate. Typical yield: 66%.^{[1][2]} Purity: >98%.

Deep Dive: Kinetic Control (Continuous Flow) Mechanism & Rationale

In a batch reactor, local "hotspots" of high reagent concentration can lead to di-protection even with careful addition. Continuous flow chemistry mitigates this by ensuring extremely efficient mixing and precise residence times. By controlling the flow rate, the mono-protected product is removed from the reaction zone before it can react a second time.

- Why it works: The residence time () is tuned to match the rate constant (first protection) while being significantly shorter than the time required for (second protection).
- Literature Validation: Wille & Kaiser (2015) reported yields up to 91% for various diamines using a simple PTFE coil reactor.

Visualization: Flow Reactor Logic

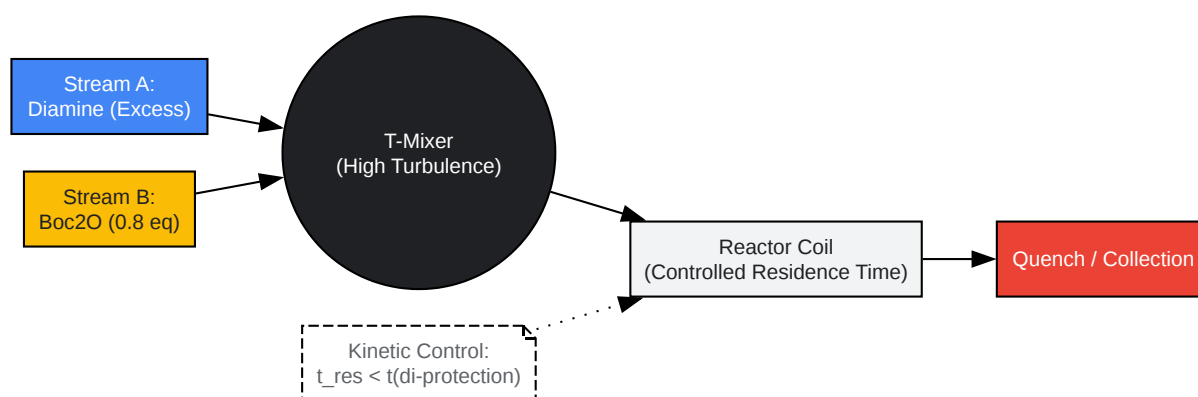

[Click to download full resolution via product page](#)

Caption: Flow synthesis prevents over-reaction by limiting the contact time between the mono-protected product and the electrophile.

Experimental Protocol (Flow)

Target: N-Boc-piperazine Reference: Adapted from Wille & Kaiser (2015) and Sigma-Aldrich Application Notes.

- Feed Preparation:
 - Solution A: Piperazine (1.3 M in Methanol).
 - Solution B:

(1.04 M in Methanol, 0.8 eq relative to diamine).
- Reactor Setup:
 - Use a PTFE tubular reactor (0.5 mm ID, approx. 10 mL volume).
 - Connect inputs to dual syringe pumps or HPLC pumps.
- Parameters:
 - Temperature: 30 °C.
 - Flow Rate: Combined flow rate optimized to achieve a residence time of ~5–10 minutes (e.g., 1–2 mL/min depending on reactor volume).
- Operation:
 - Pump solutions through a T-mixer.
 - Collect output.[\[1\]](#)[\[2\]](#)[\[3\]](#)[\[4\]](#)[\[5\]](#)[\[6\]](#)[\[7\]](#)[\[8\]](#)[\[9\]](#)
- Workup:
 - Solvent evaporation.
 - The use of 0.8 eq

ensures that the limiting reagent is fully consumed, leaving mostly mono-product and unreacted diamine.
 - Unreacted piperazine is removed via aqueous wash or sublimation.

- Result: Yields typically 45–60% per pass, but with >95% selectivity (clean product). Unreacted diamine can be recycled.

References

- Wille, G., & Kaiser, F. (2015). Flow-Mediated Synthesis of Boc, Fmoc, and Ddiv Monoprotected Diamines. *Organic Letters*. [[Link](#)]
- Servín, F. A., et al. (2017).[2] General Method for Selective Mono-Boc Protection of Diamines. *Journal of the Mexican Chemical Society*.[2] [[Link](#)]
- Lee, D. W., & Ha, H. J. (2007). Selective Mono-BOC Protection of Diamines. *Synthetic Communications*. [[Link](#)]
- Pittelkow, M., et al. (2007). Selective Mono-Carbamate Protection of Aliphatic Diamines Using Alkyl Phenyl Carbonates. *Organic Syntheses*. [[Link](#)]
- Krapcho, A. P., & Kuell, C. S. (1990). Mono-Protected Diamines.[1][10][2][3] N-tert-Butoxycarbonyl- α,ω -Alkanediamines from α,ω -Alkanediamines.[3] *Synthetic Communications*. [[Link](#)]

Need Custom Synthesis?

BenchChem offers custom synthesis for rare earth carbides and specific isotopic labeling.

Email: info@benchchem.com or [Request Quote Online](#).

Sources

- 1. [General Method for Selective Mono-Boc Protection of Diamines and Thereof](#) [scielo.org.mx]
- 2. redalyc.org [redalyc.org]
- 3. semanticscholar.org [semanticscholar.org]
- 4. chemmethod.com [chemmethod.com]
- 5. researchgate.net [researchgate.net]
- 6. masterorganicchemistry.com [masterorganicchemistry.com]

- [7. researchgate.net \[researchgate.net\]](#)
- [8. researchgate.net \[researchgate.net\]](#)
- [9. ohsu.edu \[ohsu.edu\]](#)
- [10. researchgate.net \[researchgate.net\]](#)
- To cite this document: BenchChem. [Technical Guide: Comparative Strategies for Mono-Protected Diamine Synthesis]. BenchChem, [2026]. [Online PDF]. Available at: [<https://www.benchchem.com/product/b1628918/docs#technical-guide-comparative-strategies-for-mono-protected-diamine-synthesis>]

Disclaimer & Data Validity:

The information provided in this document is for Research Use Only (RUO) and is strictly not intended for diagnostic or therapeutic procedures. While BenchChem strives to provide accurate protocols, we make no warranties, express or implied, regarding the fitness of this product for every specific experimental setup.

Technical Support: The protocols provided are for reference purposes. Unsure if this reagent suits your experiment?

Need Industrial/Bulk Grade? [Request Custom Synthesis Quote](#)

BenchChem

Our mission is to be the trusted global source of essential and advanced chemicals, empowering scientists and researchers to drive progress in science and industry.

Contact

Address: 3281 E Guasti Rd
Ontario, CA 91761, United States
Phone: (601) 213-4426
Email: info@benchchem.com

[Contact our Ph.D. Support Team for a compatibility check](#)

