

Comparative Guide: 4-Aminoindole vs. 7-Azaindole Reactivity

Author: BenchChem Technical Support Team. **Date:** April 2026

Compound of Interest

Compound Name: 7-Methyl-1H-indol-4-amine

CAS No.: 90868-08-9

Cat. No.: B1628889

[Get Quote](#)

Executive Summary

This guide provides a technical comparison between 4-aminoindole and 7-azaindole (1H-pyrrolo[2,3-b]pyridine). While both share the core bicyclic indole architecture, their electronic profiles are diametrically opposed.^[1]

- 4-Aminoindole is an electron-rich system. The C4-amino group acts as a strong -donor (+M effect), significantly activating the pyrrole ring and the benzene ring (specifically C5/C7) toward electrophiles. It is prone to oxidation and requires mild conditions.
- 7-Azaindole is an electron-deficient bioisostere. The N7 atom (pyridine-like) exerts a strong inductive (-I) and mesomeric (-M) withdrawing effect, deactivating the ring toward electrophilic attack but enabling nucleophilic attack and acidity changes.

Part 1: Electronic Landscape & Physical Properties^[1]

The reactivity differences stem fundamentally from the perturbation of the indole

-system.

Electronic Distribution Analysis

Feature	4-Aminoindole	7-Azaindole
Electronic Nature	Super-Activated (-excessive)	Deactivated (-deficient pyridine ring)
Dominant Effect	C4-NH (+M) donates density into C3, C5, C7.	N7 (-I/-M) withdraws density from C2, C3, C6.[1]
N1-H Acidity (pKa)	~17.5 (Less acidic than indole)	~13.2 (More acidic than indole)
Basicity	Basic at C4-NH (pKa ~4-5)	Basic at N7 (pKa ~4.6)
Oxidation Potential	High (Prone to quinone imine formation)	Low (Stable to oxidative conditions)
H-Bonding	Donor (N1-H, 4-NH)	Donor (N1-H) + Acceptor (N7)

Structural Visualization

The following diagram illustrates the divergent reactivity nodes driven by electronic effects.

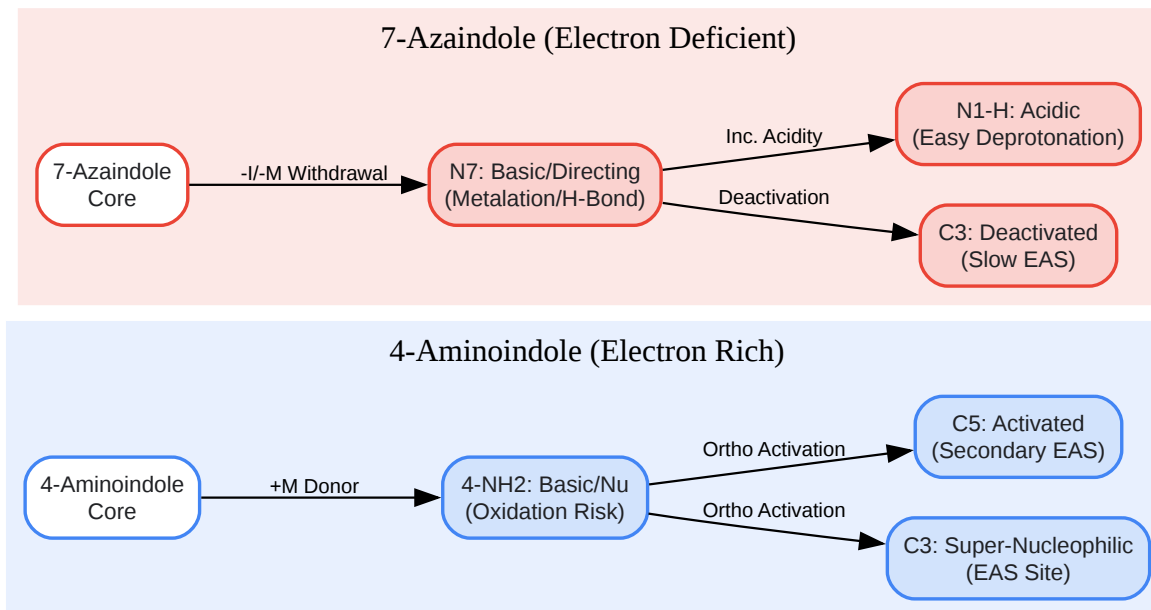

[Click to download full resolution via product page](#)

Figure 1: Comparative electronic activation maps. Blue nodes indicate electron-rich sites; Red nodes indicate electron-deficient/acidic sites.

Part 2: Reactivity Profiles

Electrophilic Aromatic Substitution (EAS)

4-Aminoindole:

- **Reactivity:** Extremely high. The amino group reinforces the natural nucleophilicity of C3.
- **Regioselectivity:** Exclusively C3 under standard conditions. However, unlike plain indole, the C5 and C7 positions are also activated (ortho/para to amine).[1] If C3 is blocked, EAS can occur at C5.[1]
- **Challenges:** The amino group is incompatible with strong Lewis acids (complexation) or oxidants (nitration is difficult without protection).

7-Azaindole:

- **Reactivity:** Moderate to Low. The pyridine ring pulls electron density, making the C3 position less nucleophilic than in indole.
- **Regioselectivity:** Still favors C3 (beta to pyrrole nitrogen), but requires forcing conditions or activated electrophiles.[1]
- **Halogenation:** Requires N-halosuccinimides (NXS) rather than elemental halogens to avoid side reactions at N7.

Metal-Mediated C-H Functionalization[2][3]

7-Azaindole (The "Directing Group" Advantage):

- **Lithiation:** The N7 lone pair is a built-in directing group.
 - **C2-Lithiation:** Achieved by protecting N1 (e.g., with SEM or Boc) and using n-BuLi. The N7 helps stabilize the transition state.
 - **Minisci Reaction:** 7-Azaindole is an excellent substrate for radical alkylation (Minisci). Nucleophilic alkyl radicals attack the electron-deficient C2 position (or C4 under specific acidic conditions).

4-Aminoindole:

- **Lithiation:** Difficult without protecting the 4-NH

(which has acidic protons). Double deprotonation is required, or conversion to a directed metalation group (DMG) like a pivalamide.[1]

Acidity & N-Functionalization[4]

Property	4-Aminoindole	7-Azaindole	Implications
N1-H pKa (DMSO)	~17.5	~13.2	7-Azaindole deprotonates with weaker bases (e.g., KCO/CsCO).
N-Alkylation	Slower; competes with 4-NH alkylation.	Fast and selective at N1 (N7 is not nucleophilic for alkylation under basic conditions).	

Part 3: Experimental Protocols

Protocol A: C3-Halogenation (Comparative)

1. 4-Aminoindole (Mild Conditions Required)

- Objective: Synthesis of 3-bromo-4-aminoindole.
- Note: The free amine is sensitive. Oxidants like Br will cause polymerization (aniline black type).
- Reagents: NBS (1.0 eq), DMF, 0°C.
- Procedure:
 - Dissolve 4-aminoindole in anhydrous DMF (0.1 M) under Argon.
 - Cool to 0°C.
 - Add N-bromosuccinimide (NBS) dropwise as a solution in DMF.

- Stir for 30 mins. (Reaction is instantaneous due to activation).
- Critical: Quench immediately with aqueous sodium thiosulfate to prevent over-bromination or oxidation.

2. 7-Azaindole (Standard Conditions)

- Objective: Synthesis of 3-bromo-7-azaindole.

- Reagents: Br

(1.1 eq) or NBS, DMF, RT.[1]

- Procedure:

- Dissolve 7-azaindole in DMF.
- Add elemental bromine (Br) dropwise at room temperature.
- Stir for 1 hour.
- Pour into ice water/ammonia. The product precipitates as a solid.
- Observation: The pyridine ring stabilizes the molecule against oxidative degradation, allowing the use of elemental bromine.

Protocol B: Minisci Alkylation (Specific to 7-Azaindole)

This reaction exploits the electron deficiency of 7-azaindole, a pathway inaccessible to electron-rich 4-aminoindole.

- Objective: C2-alkylation of 7-azaindole.
- Reagents: 7-azaindole, Carboxylic Acid (Alkyl source), AgNO

(cat.), (NH

)

S

O

, TFA/Water.[1][2]

- Mechanism: Silver-catalyzed decarboxylation generates an alkyl radical, which attacks the protonated 7-azaindole at C2.
- Step-by-Step:
 - Suspend 7-azaindole (1 mmol) in water/TFA (1:1).
 - Add alkyl carboxylic acid (2 mmol) and AgNO₃ (0.2 mmol).
 - Heat to 70°C.
 - Add ammonium persulfate (1.5 mmol) solution dropwise over 20 mins.
 - Neutralize and extract.

Part 4: Decision Framework & Workflow

Use this flowchart to select the correct functionalization strategy.

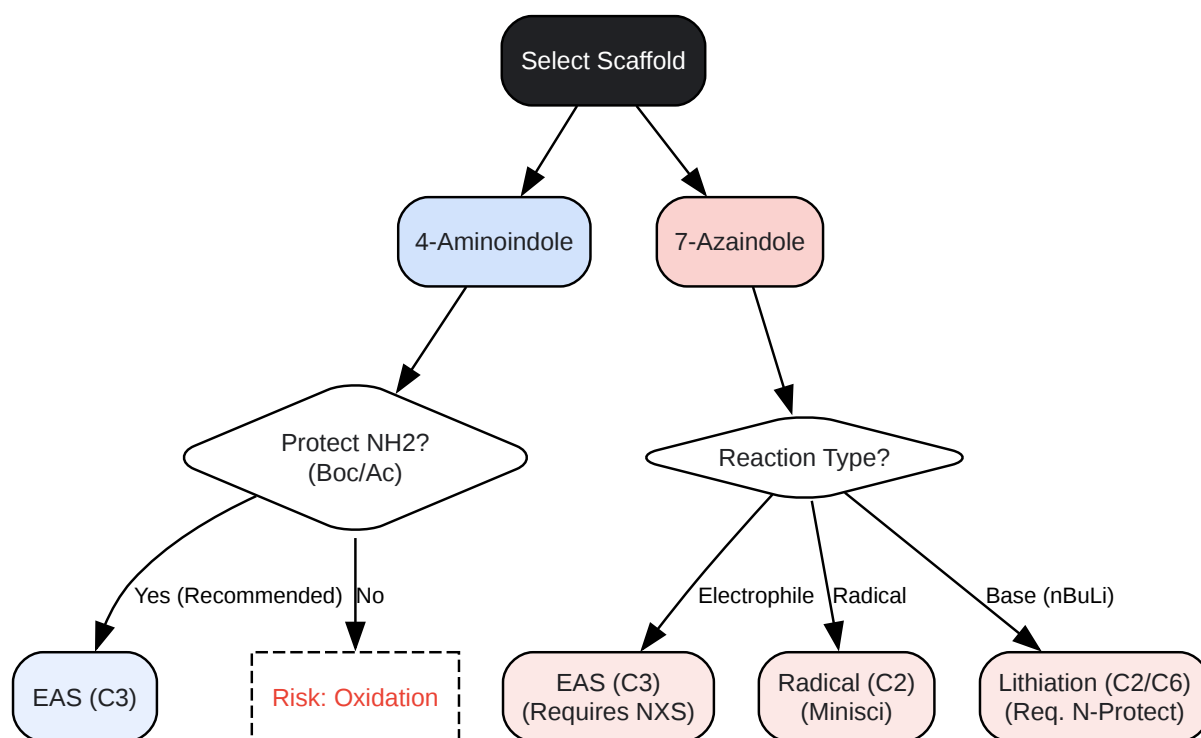

[Click to download full resolution via product page](#)

Figure 2: Synthetic decision tree for functionalizing 4-aminoindole and 7-azaindole.

References

- Popowycz, F., et al. (2014).[1] "The Azaindole Framework in the Design of Kinase Inhibitors." *Pharmaceuticals*, 7(11), 292-327.[1] [Link](#)
- Kütt, A., et al. (2018).[1] "The Acidity of Weak NH Acids: Expanding the pKa Scale in Acetonitrile." *Journal of Organic Chemistry*. [Link](#)
- Song, J.J., et al. (2002).[1] "Organometallic Methods for the Synthesis and Functionalization of Azaindoles." *Chemical Society Reviews*. [Link](#)
- Laha, J.K., et al. (2012).[1] "Palladium-catalyzed C–N and C–O bond formation of N-substituted 4-bromo-7-azaindoles." *Beilstein Journal of Organic Chemistry*. [Link](#)
- ChemicalBook. (2024). "7-Azaindole Properties and Reactivity Profile." [Link](#)

Need Custom Synthesis?

BenchChem offers custom synthesis for rare earth carbides and specific isotopic labeling.

Email: info@benchchem.com or [Request Quote Online](#).

Sources

- [1. alfa-chemistry.com \[alfa-chemistry.com\]](http://alfa-chemistry.com)
- [2. Practical and Regioselective Synthesis of C-4-Alkylated Pyridines \[organic-chemistry.org\]](http://organic-chemistry.org)
- To cite this document: BenchChem. [Comparative Guide: 4-Aminoindole vs. 7-Azaindole Reactivity]. BenchChem, [2026]. [Online PDF]. Available at: [\[https://www.benchchem.com/product/b1628889/docs#comparative-guide-4-aminoindole-vs-7-azaindole-reactivity\]](https://www.benchchem.com/product/b1628889/docs#comparative-guide-4-aminoindole-vs-7-azaindole-reactivity)

Disclaimer & Data Validity:

The information provided in this document is for Research Use Only (RUO) and is strictly not intended for diagnostic or therapeutic procedures. While BenchChem strives to provide accurate protocols, we make no warranties, express or implied, regarding the fitness of this product for every specific experimental setup.

Technical Support: The protocols provided are for reference purposes. Unsure if this reagent suits your experiment?

Need Industrial/Bulk Grade? [Request Custom Synthesis Quote](#)

BenchChem

Our mission is to be the trusted global source of essential and advanced chemicals, empowering scientists and researchers to drive progress in science and industry.

Contact

Address: 3281 E Guasti Rd

Ontario, CA 91761, United States

Phone: (601) 213-4426

Email: info@benchchem.com

Contact our Ph.D. Support Team for a compatibility check