

Controlling temperature variables for optimal quinoline ring closure

Author: BenchChem Technical Support Team. **Date:** April 2026

Compound of Interest

Compound Name: 1,2,2,4-tetramethylquinoline

CAS No.: 46255-82-7

Cat. No.: B1627471

[Get Quote](#)

Technical Support Center: Heterocycle Synthesis Optimization Hub

Topic: Controlling Temperature Variables for Optimal Quinoline Ring Closure Ticket ID: Q-SYNTH-001 Assigned Specialist: Senior Application Scientist (Process Chemistry Division)

Introduction: The Thermal Landscape of Cyclization

Welcome to the Heterocycle Optimization Hub. You are likely here because your quinoline synthesis—whether via Skraup, Friedländer, or Conrad-Limpach—is suffering from tar formation, poor regioselectivity, or violent exotherms.

In quinoline synthesis, temperature is not merely an energy source; it is a molecular switch. It dictates whether you form a kinetic enamine or a thermodynamic amide, and it determines whether your acrolein intermediate cyclizes into a ring or polymerizes into "tar." This guide replaces generic textbook advice with field-proven thermal control protocols.

Module 1: Managing the Skraup/Doebner-von Miller Exotherm

The Challenge: The Skraup synthesis involves the in-situ generation of acrolein from glycerol. This reaction is notoriously autocatalytic and exothermic. If the temperature ramp is too aggressive, the reaction enters a "runaway" state, leading to rapid pressure buildup and the polymerization of acrolein (tar) rather than ring closure.

The Protocol: The "Moderated Ramp" System

Objective: Decouple the acrolein formation rate from the cyclization rate.

Reagents:

- Aniline (1.0 equiv)
- Glycerol (3.0 equiv)
- Sulfuric Acid (, conc.)^{[1][2]}
- The Moderator: Ferrous Sulfate () or Boric Acid.

Step-by-Step Thermal Logic:

- The Cold Mix: Combine aniline, glycerol, and the moderator () in the flask.
- Acid Addition (The First Exotherm): Add dropwise.
 - Checkpoint: The temperature will spontaneously rise to ~70–80°C. Do not apply external heat yet. Allow the exotherm to plateau.

- The Critical Ramp: Apply external heat to reach an internal temperature of 115–120°C.
 - Warning: At ~120°C, the dehydration of glycerol accelerates. If you see sudden vigorous boiling (white foam), remove the heat source immediately. The reaction is now self-sustaining.
- The Reflux: Only re-apply heat once the spontaneous boiling subsides. Maintain reflux (140–150°C) for 3–4 hours to drive the endothermic aromatization.

Visualizing the Safety Loop

The following diagram illustrates the decision logic for managing the Skraup exotherm.

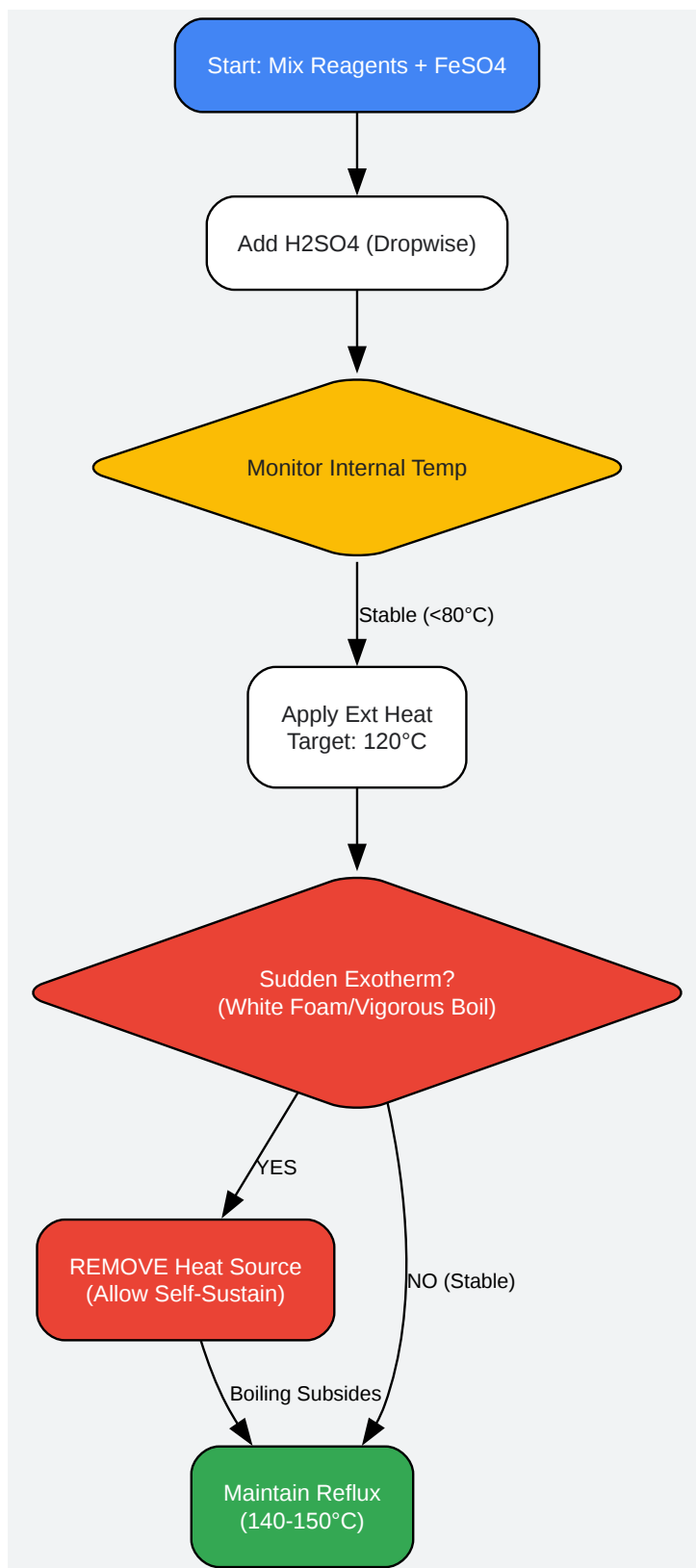

[Click to download full resolution via product page](#)

Caption: Logic flow for managing the autocatalytic exotherm in Skraup synthesis. Note the critical "Remove Heat" step at the onset of self-sustained boiling.[3][4]

Module 2: Kinetic vs. Thermodynamic Control (Conrad-Limpach vs. Knorr)

The Challenge: Reacting an aniline with a

-ketoester can yield two different isomers.[5] The outcome depends entirely on the temperature of the initial condensation step.

- Kinetic Product (Conrad-Limpach): 4-Hydroxyquinoline (4-Quinolone).[5][6]
- Thermodynamic Product (Knorr): 2-Hydroxyquinoline (2-Quinolone).[5]

Mechanism & Temperature Causality

The amine nitrogen can attack two electrophiles: the ketone (more reactive) or the ester (less reactive).[5]

- Low Temperature (<100°C): The amine attacks the most reactive site (ketone) to form an Enamine (Schiff Base). This is reversible. If you "lock" this in by cyclizing at high heat (C), you get the 4-isomer.
- Medium Temperature (110–140°C): The kinetic enamine forms but reverts. The amine then attacks the ester (slower, but forms a stable amide bond). This leads to the Amide (Anilide). Cyclization then yields the 2-isomer.

Comparative Protocol Table

Variable	Conrad-Limpach (Kinetic)	Knorr (Thermodynamic)
Target Isomer	4-Hydroxyquinoline	2-Hydroxyquinoline
Step 1 Temp	Room Temp to 60°C	110°C – 140°C
Step 1 Time	Long (Overnight)	Short (1–2 hours)
Intermediate	-aminoacrylate (Enamine)	-ketoanilide (Amide)
Catalyst	Acid catalyst (HCl) often used	No catalyst initially
Step 2 (Cyclization)	Flash Heat to 250°C (Diphenyl ether)	Treat with conc. (100°C)
Why this works?	Low temp prevents amide formation. High temp flash cyclizes enamine before it reverts.	High temp overcomes activation energy for ester attack; amide is thermodynamically stable.

Visualizing the Regioselectivity Pathway

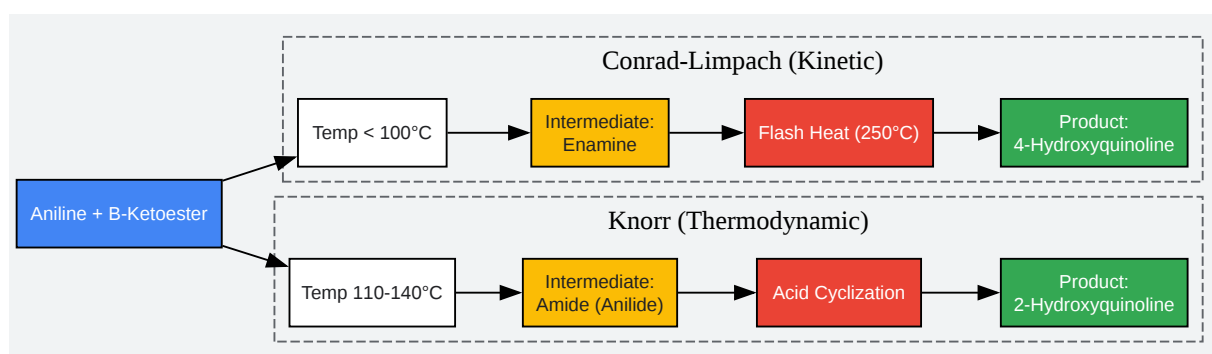

[Click to download full resolution via product page](#)

Caption: Bifurcation of reaction pathways based on initial temperature control. Note that the 4-isomer requires a low-temperature start followed by a high-temperature finish.

Module 3: Modern Acceleration (Microwave Friedländer)

The Challenge: The Friedländer synthesis (o-aminoaldehyde + ketone) often requires prolonged reflux (24–48 hours) in ethanol, leading to decomposition of the sensitive aminoaldehyde.

The Solution: Microwave irradiation allows for "superheating" of solvents (above boiling point) in sealed vessels, accelerating the rate-limiting aldol condensation step.

Optimized Microwave Protocol

- Solvent: Ethanol or Solvent-Free (Neat).
- Catalyst: Solid-supported acid (e.g., Montmorillonite) or base (KOH).
- Parameters:
 - Temperature: 120°C – 160°C (Fixed).
 - Time: 5 – 15 minutes.
 - Pressure: Max 250 psi (ensure vessel rating).
- Troubleshooting: If yield is low, increase temp to 140°C rather than extending time. Prolonged microwave exposure degrades the product.

FAQ & Troubleshooting Matrix

Q: My Skraup reaction turned into a solid black solid that I can't remove from the flask. What happened? A: You likely experienced "runaway polymerization." This happens when the initial heating is too fast. The acrolein polymerizes faster than it reacts with the aniline.

- Fix: Use the Moderated Ramp (Module 1). Add
 - . Stop heating immediately when boiling starts.

Q: In the Conrad-Limpach synthesis, I am getting a mixture of isomers. Why? A: Your initial mixing temperature was likely too high (allowing some amide formation) or your cyclization ramp was too slow (allowing the enamine to revert/equilibrate).

- Fix: Mix reagents at room temperature. For the cyclization step, drop the enamine into pre-heated diphenyl ether (250°C) rather than heating them up together. This is called "Flash Cyclization."

Q: Can I use a water bath for the Friedländer reaction? A: Generally, no. The condensation step usually requires temperatures

C (Ethanol reflux) or higher. A water bath limits you to 100°C. An oil bath or microwave reactor is required to overcome the activation energy for the dehydration step.

Symptom	Probable Cause	Corrective Action
Violent Eruption (Skraup)	Rapid acid addition; No moderator.	Add acid dropwise; Use ; Cool immediately upon exotherm.
Low Yield (Friedländer)	Aldol adduct formed but didn't cyclize.	Increase Temp (needs heat to drive); Switch to Microwave (140°C).
Wrong Isomer (Conrad-Limpach)	Initial temp > 80°C.	Maintain Step 1 at < 60°C. Ensure Step 2 is instantaneous high heat.
Tarry Residue	Polymerization of intermediates. ^[4]	Reduce reaction time; Lower acid concentration; Use Nitrogen atmosphere.

References

- Organic Syntheses. "Quinoline synthesis via Skraup reaction; 6-Methoxy-8-nitroquinoline." Organic Syntheses, Coll.^[7]^[8] Vol. 3, p. 568 (1955). [Link](#)

- Manske, R. H. F. "The Chemistry of Quinolines." *Chemical Reviews*, 30(1), 113–144 (1942). [Link](#)
- Gould, R. G., & Jacobs, W. A. "The Synthesis of Certain Substituted Quinolines and 5,6-Benzoquinolines." *Journal of the American Chemical Society*, 61(10), 2890–2895 (1939). (Foundational work on Conrad-Limpach kinetics). [Link](#)
- Caira, M. R., et al. "Microwave-Assisted Synthesis of Quinoline Derivatives." *ACS Combinatorial Science* (formerly *Journal of Combinatorial Chemistry*), various issues. (General reference for microwave parameters). [Link](#)
- BenchChem Technical Support. "Navigating the Skraup Quinoline Synthesis: A Technical Support Guide." (2025).^{[1][3][4][9]} [Link](#)

Need Custom Synthesis?

BenchChem offers custom synthesis for rare earth carbides and specific isotopic labeling.

Email: info@benchchem.com or [Request Quote Online](#).

Sources

- 1. [benchchem.com](https://www.benchchem.com) [[benchchem.com](https://www.benchchem.com)]
- 2. [Organic Syntheses Procedure](https://orgsyn.org) [orgsyn.org]
- 3. pdf.benchchem.com [pdf.benchchem.com]
- 4. [benchchem.com](https://www.benchchem.com) [[benchchem.com](https://www.benchchem.com)]
- 5. [Conrad–Limpach synthesis - Wikipedia](https://en.wikipedia.org/wiki/Conrad-Limpach_synthesis) [en.wikipedia.org]
- 6. [Conrad-Limpach Reaction \(Chapter 17\) - Name Reactions in Organic Synthesis](https://www.cambridge.org/core/books/organic-synthesis/conrad-limpach-reaction) [[cambridge.org](https://www.cambridge.org)]
- 7. [Friedländer synthesis - Wikipedia](https://en.wikipedia.org/wiki/Friedl%C3%A4nder_synthesis) [en.wikipedia.org]
- 8. pubs.acs.org [pubs.acs.org]
- 9. pdf.benchchem.com [pdf.benchchem.com]
- To cite this document: BenchChem. [Controlling temperature variables for optimal quinoline ring closure]. BenchChem, [2026]. [Online PDF]. Available at:

[\[https://www.benchchem.com/product/b1627471/docs#controlling-temperature-variables-for-optimal-quinoline-ring-closure\]](https://www.benchchem.com/product/b1627471/docs#controlling-temperature-variables-for-optimal-quinoline-ring-closure)

Disclaimer & Data Validity:

The information provided in this document is for Research Use Only (RUO) and is strictly not intended for diagnostic or therapeutic procedures. While BenchChem strives to provide accurate protocols, we make no warranties, express or implied, regarding the fitness of this product for every specific experimental setup.

Technical Support: The protocols provided are for reference purposes. Unsure if this reagent suits your experiment?

Need Industrial/Bulk Grade? [Request Custom Synthesis Quote](#)

BenchChem

Our mission is to be the trusted global source of essential and advanced chemicals, empowering scientists and researchers to drive progress in science and industry.

Contact

Address: 3281 E Guasti Rd
Ontario, CA 91761, United States
Phone: (601) 213-4426
Email: info@benchchem.com

[Contact our Ph.D. Support Team for a compatibility check](#)