

Chemical Profile & Mechanistic Risk Assessment

Author: BenchChem Technical Support Team. **Date:** April 2026

Compound of Interest

Compound Name: Ethane-1,1,2,2-d4

CAS No.: 3681-29-6

Cat. No.: B1627052

[Get Quote](#)

Before executing any disposal protocol, you must understand the physical behavior of the molecule. **Ethane-1,1,2,2-d4** behaves chemically like standard ethane but carries an isotopic mass shift (M+4). Its primary hazards stem from its physical state and flammability, not chemical toxicity.

According to the , the compound is classified under GHS as an extremely flammable gas (H220) and a gas under pressure (H280).

Table 1: Quantitative Hazard Data & Operational Implications

Property	Value	Operational & Mechanistic Implication
CAS Number	3681-29-6	Unique identifier for the tetradeuterated isotopologue; required for EHS waste manifests.
Linear Formula	HCD ₂ CD ₂ H	Isotopic mass shift (M+4); critical for MS calibration but identical in fire risk to C ₂ H ₆ .
Boiling Point	-88 °C	Exists as a compressed gas. Rapid expansion of leaking gas absorbs ambient heat, causing severe frostbite[1].
Vapor Density	1.05 (Air = 1.0)	Marginally heavier than air. Leaks will pool in low-lying areas, trenches, or lower exhaust ductwork.
Flammability Limits	LEL ~3.0%, UEL ~12.5%	Forms explosive mixtures with ambient air easily. Requires strict elimination of static and ignition sources[1].
Hazard Codes	H220, H280	Extremely flammable; pressurized. Dictates the mandatory use of non-sparking tools.

Logistical & Operational Disposal Workflow

The disposal of an **Ethane-1,1,2,2-d₄** cylinder is a logistical pathway determined by the internal pressure of the vessel. We do not vent isotopic gases into standard fume hoods because the vapor density (1.05) allows the gas to pool in the ductwork, creating a catastrophic explosion risk if it meets a spark from an exhaust fan motor[2].

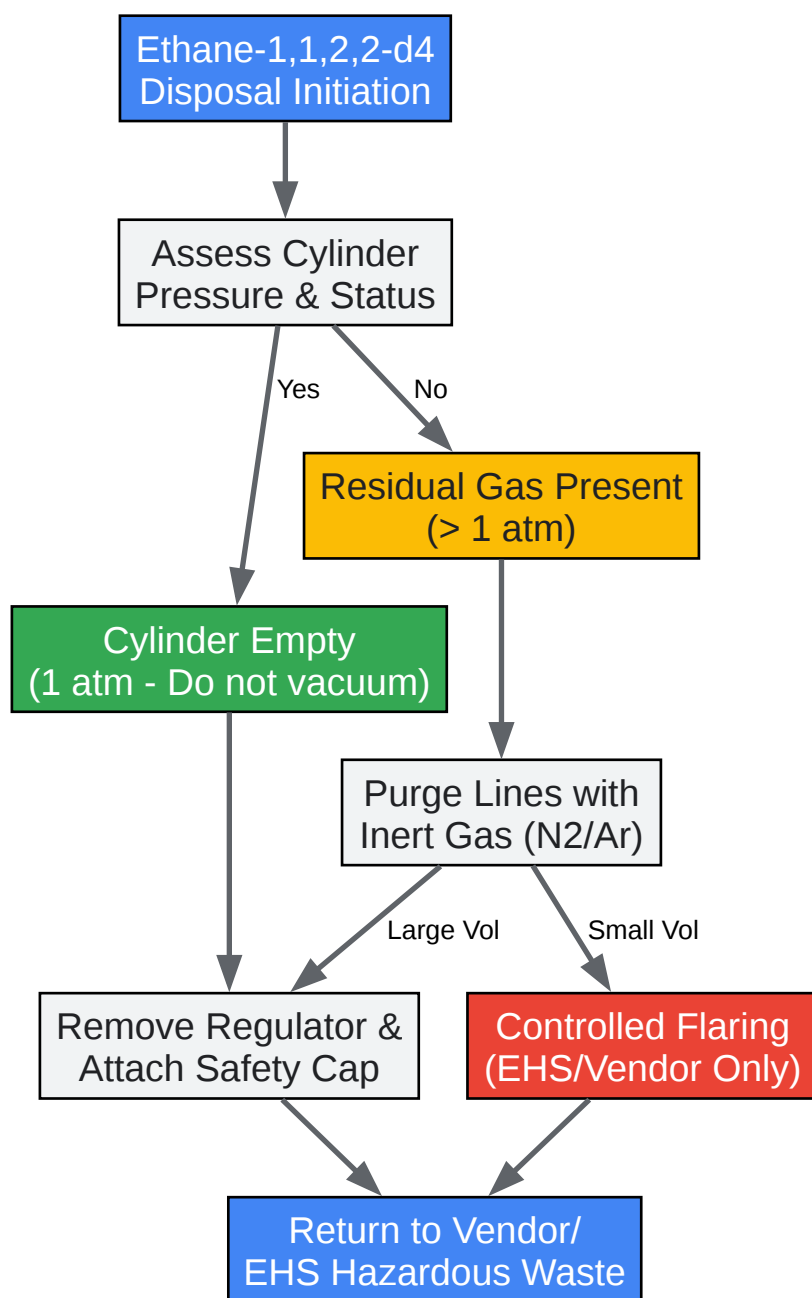

[Click to download full resolution via product page](#)

Operational workflow for the safe decommissioning and disposal of **Ethane-1,1,2,2-d4** cylinders.

Step-by-Step Decommissioning Methodology

This protocol is designed as a self-validating system. Every step includes a verification check to ensure the hazard has been neutralized before proceeding.

Phase 1: Pre-Disposal System Purging (The "Sweep")

Causality: Disconnecting a regulator leaves a dead volume of ethane. When exposed to atmospheric oxygen, it immediately enters its flammability limit (LEL 3.0%). Purging sweeps this dead volume, replacing the flammable gas with an inert buffer before the mechanical seal is broken.

- Isolate the Source: Close the main cylinder valve of the **Ethane-1,1,2,2-d4** tank completely. Do not over-tighten, as this can deform the brass valve seat and cause micro-leaks.
- Depressurize the Line: Open the downstream system valve to consume the residual gas trapped in the regulator. Watch the high-pressure gauge drop to zero.
- Inert Gas Sweep: Connect a high-purity inert gas line (Nitrogen or Argon) to the system's purge valve. Flush the lines at 10-15 psi for a minimum of 5 minutes[3].
- Validation (Self-Check): Apply a liquid leak detector solution (e.g., Snoop) to the regulator fittings. If no bubbles form, the system is depressurized and safe to disassemble.

Phase 2: Cylinder Decommissioning

Causality: Standard steel tools can strike a spark against the cylinder collar, igniting trace residual gas. Regulators are fragile; a sheared valve on a pressurized cylinder turns the heavy vessel into a kinetic projectile.

- Regulator Removal: Using a non-sparking wrench (e.g., beryllium-copper or bronze), carefully disconnect the regulator[2].
- Cap and Seal: Immediately thread the original steel safety cap back onto the cylinder collar. Never transport or dispose of a cylinder without this cap securely in place[3].
- Labeling: Affix a highly visible "Hazardous Waste - Do Not Use" tag to the cylinder. If the cylinder still contains pressurized gas, record the estimated pressure on the tag for the vendor.

Phase 3: Logistical Segregation and Vendor Return

Causality: Segregation breaks the "fire triangle" (fuel + oxidizer + heat). Keeping flammable gases away from oxidizers ensures that a leak in one system cannot catastrophically feed the other.

- Segregation: Move the capped cylinder to a designated hazardous gas storage area using a chained cylinder hand-truck. According to and [4], flammable gas cylinders must be stored at least 20 feet away from oxidizing gases (e.g., Oxygen, Nitrous Oxide) or separated by a non-combustible barrier with a 1/2-hour fire resistance rating.
- Restraint: Secure the cylinder to a wall rack using two chains—one at 1/3 the height of the cylinder and one at 2/3 the height[5].
- EHS/Vendor Handoff: Do not attempt to flare or vent full cylinders yourself. Contact your Environmental Health and Safety (EHS) office to arrange a vendor return (e.g., Sigma-Aldrich or your local specialty gas supplier). The vendor will safely recapture or flare the isotopic gas[2].

Emergency Response & Spill Management

If a continuous leak is detected (indicated by a hissing sound or a combustible gas monitor alarm) and cannot be immediately stopped by tightening the valve:

- Evacuate & Isolate: Clear the laboratory immediately. Hit the emergency lab exhaust button to maximize room ventilation. Shut off all potential ignition sources (hot plates, electrical relays) on your way out.
- Do Not Extinguish: If the leaking gas has ignited, do not attempt to extinguish the flame unless the gas flow can be stopped safely. Extinguishing the flame while the gas continues to leak will result in a massive, invisible explosive cloud[6].
- Notify: Call EHS and facility security. Provide the exact chemical name (**Ethane-1,1,2,2-d4**) and explicitly state its vapor density (1.05). This critical data point informs emergency responders that the gas will pool in low-lying areas and trenches rather than dissipating upward[4].

References

- Synergy Recycling. Disposal of Ethane (C₂H₆). Retrieved from [\[Link\]](#)
- Linde Gas. Safety Data Sheet: Ethane. Retrieved from [\[Link\]](#)
- Stanford Environmental Health & Safety. Ethane Safe Handling Guideline. Retrieved from [\[Link\]](#)
- UCLA Environment, Health & Safety. Compressed Gas Cylinder Storage and Handling. Retrieved from [\[Link\]](#)

Need Custom Synthesis?

BenchChem offers custom synthesis for rare earth carbides and specific isotopic labeling.

Email: info@benchchem.com or [Request Quote Online](#).

Sources

- 1. Disposal of Ethane (C₂H₆) — Synergy Recycling [synergy-recycling.co.uk]
- 2. pdf.benchchem.com [pdf.benchchem.com]
- 3. uwyo.edu [uwyo.edu]
- 4. www-group.slac.stanford.edu [www-group.slac.stanford.edu]
- 5. Laboratory Standard & Design Guidelines – Stanford Environmental Health & Safety [ehs.stanford.edu]
- 6. produkte.linde-gas.at [produkte.linde-gas.at]
- To cite this document: BenchChem. [Chemical Profile & Mechanistic Risk Assessment]. BenchChem, [2026]. [Online PDF]. Available at: [<https://www.benchchem.com/product/b1627052/docs#chemical-profile-mechanistic-risk-assessment>]

Disclaimer & Data Validity:

The information provided in this document is for Research Use Only (RUO) and is strictly not intended for diagnostic or therapeutic procedures. While BenchChem strives to provide

accurate protocols, we make no warranties, express or implied, regarding the fitness of this product for every specific experimental setup.

Technical Support: The protocols provided are for reference purposes. Unsure if this reagent suits your experiment?

Need Industrial/Bulk Grade? [Request Custom Synthesis Quote](#)

BenchChem

Our mission is to be the trusted global source of essential and advanced chemicals, empowering scientists and researchers to drive progress in science and industry.

Contact

Address: 3281 E Guasti Rd

Ontario, CA 91761, United States

Phone: (601) 213-4426

Email: info@benchchem.com

[Contact our Ph.D. Support Team for a compatibility check](#)