

Application Note: Strategic Reagents for the Synthesis of N-Substituted Acetimidamides

Author: BenchChem Technical Support Team. **Date:** April 2026

Compound of Interest

Compound Name: *N*-(1*H*-Pyrazol-3-yl)acetimidamide

CAS No.: 51247-95-1

Cat. No.: B1627592

[Get Quote](#)

).

Abstract

N-substituted acetimidamides are critical pharmacophores in medicinal chemistry, serving as bioisosteres for guanidines and precursors to imidazoles, pyrimidines, and quinazolines. Despite their structural simplicity, their synthesis is often plagued by poor atom economy, moisture sensitivity, or harsh conditions. This guide moves beyond generic textbook methods to present three field-proven, robust synthetic pathways: Lewis Acid-Mediated Aminolysis, Electrophilic Amide Activation, and the Modified Pinner Synthesis. We prioritize reagents that offer high functional group tolerance and scalability for drug discovery campaigns.

Strategic Reagent Selection

The synthesis of acetimidamides hinges on creating a reactive electrophilic center at the acet-carbon (

) capable of accepting a nucleophilic amine. We categorize reagents by their mechanistic entry point:

A. Lewis Acid Promoters (Direct Nitrile Addition)

- Reagent: Trimethylaluminum (AlMe₃)[1]
- Mechanism: AlMe₃ activates the amine to form a dimethylaluminum amide species, which possesses enhanced nucleophilicity to attack the nitrile carbon directly.
- Why use it: It is the "gold standard" for difficult substrates. It bypasses the need for acidic conditions and works well with electron-deficient amines (anilines) that fail in Pinner reactions.
- Constraint: Pyrophoric; requires strict anhydrous techniques.

B. Electrophilic Activators (Amide Conversion)

- Reagent: Phosphoryl Chloride (POCl₃)
- Mechanism: Converts N-substituted acetamides into highly reactive imidoyl chlorides (Vilsmeier-Haack type intermediates).
- Why use it: Ideal when the starting material is an amide rather than a nitrile. It allows for the synthesis of unsymmetrical N,N'-disubstituted amidines with precise control over substitution patterns.

C. Classical Pinner Reagents[2][3]

- Reagent: Anhydrous HCl / Ethanol
- Mechanism: Acid-catalyzed formation of an imidate ester intermediate, followed by displacement with an amine.
- Why use it: Low cost and scalable. Best for simple, acid-stable substrates where metal contamination (from Al or Cu) must be avoided.

Mechanistic Pathways & Logic

The following diagram illustrates the divergent pathways to the acetimidamide scaffold, highlighting the intermediate species that dictate reaction success.

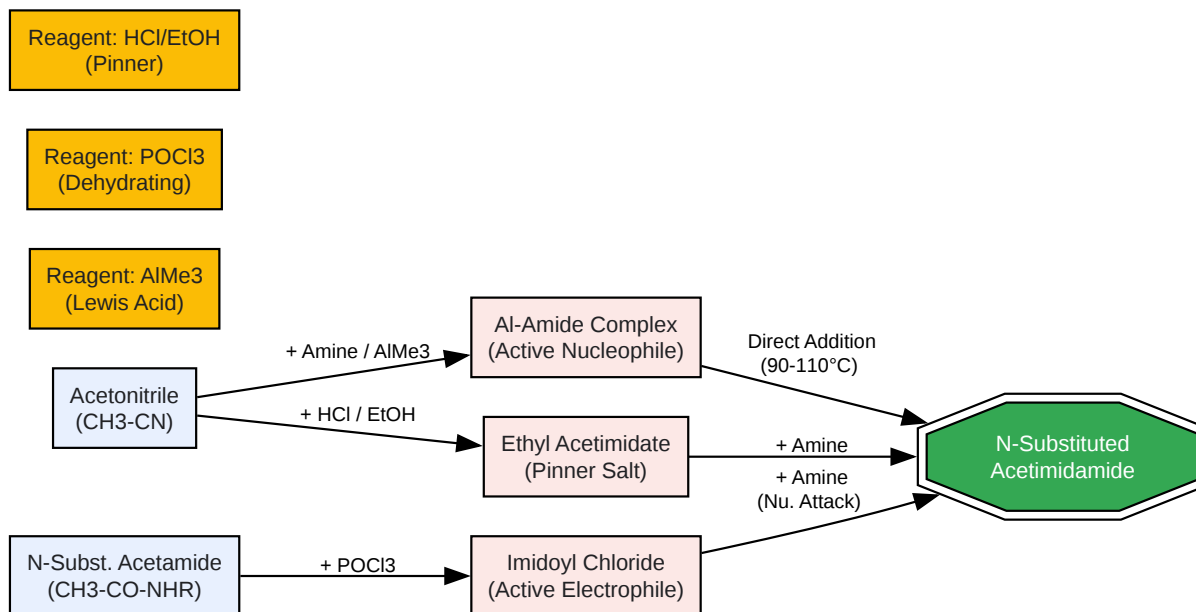

[Click to download full resolution via product page](#)

Caption: Comparative mechanistic pathways for acetimidamide synthesis. Yellow nodes indicate key reagents; Red nodes indicate reactive intermediates.

Detailed Experimental Protocols

Protocol A: Trimethylaluminum-Mediated Direct Aminolysis

Best for: Electron-deficient anilines, sterically hindered amines, and rapid library synthesis.

Reference: Adapted from Korbad & Lee [1].

Reagents:

- Acetonitrile (Starting material & Solvent component)
- Amine (1.0 equiv)[2]
- Trimethylaluminum (2.0 M in toluene, 1.1–1.2 equiv)

- Toluene (Anhydrous)

Step-by-Step Methodology:

- Setup: Flame-dry a two-neck round-bottom flask equipped with a magnetic stir bar and a reflux condenser. Flush with Argon/Nitrogen.
- Reagent Prep: Add the amine (1.0 mmol) and anhydrous toluene (5 mL) to the flask.
- Activation: Cool the solution to 0°C in an ice bath. Slowly add AlMe₃ (1.2 mmol, 0.6 mL of 2M solution) dropwise via syringe.
 - Critical Insight: Methane gas evolution will occur. Ensure the system is vented through a bubbler. Stir for 30 mins at RT to ensure formation of the active dimethylaluminum amide species ().
- Addition: Add acetonitrile (1.2 mmol) to the reaction mixture.
- Reaction: Heat the mixture to 80–100°C for 3–12 hours. Monitor by TLC or LCMS.
 - Endpoint: Disappearance of the starting amine.
- Quench: Cool to 0°C. Carefully quench by dropwise addition of 5% NaOH or Rochelle's salt solution (potassium sodium tartrate) to break the aluminum emulsion.
- Workup: Extract with Ethyl Acetate (3x). Wash combined organics with brine, dry over , and concentrate.^[2]
- Purification: Flash chromatography (DCM/MeOH/NH₃ system).

Protocol B: POCl₃ Activation of Acetamides

Best for: Converting stable acetamides into amidines; synthesis of unsymmetrical N,N'-disubstituted acetimidamides.

Reagents:

- N-Substituted Acetamide (1.0 equiv)
- Primary Amine (1.2 equiv)
- Phosphoryl Chloride (
, 1.1 equiv)
- Benzene or Toluene (Solvent)

Step-by-Step Methodology:

- Activation: Dissolve the N-substituted acetamide (1.0 mmol) in anhydrous toluene (10 mL). Add
(1.1 mmol) dropwise at room temperature.
- Imidoyl Formation: Heat to reflux for 2–3 hours.
 - Observation: The solution may darken. This step generates the imidoyl chloride intermediate (
).
- Amine Addition: Cool the mixture to ambient temperature. Add the second amine (1.2 mmol) dissolved in toluene dropwise.
 - Note: If the amine is a salt (e.g., HCl salt), add 2.5 equiv of triethylamine (TEA) to liberate the free base.
- Completion: Reflux for an additional 2–4 hours.
- Workup: Cool to RT. Basify with sat.
to pH 8–9. Extract with DCM.
- Purification: Recrystallization often works for these solid products; otherwise, use silica chromatography.

Comparative Data Analysis

Feature	AlMe3 Method	POCl3 Method	Pinner Method
Substrate Scope	Excellent (Aliphatic & Aromatic amines)	Good (Requires Amide precursor)	Limited (Steric/Electronic sensitivity)
Reaction Time	3–12 Hours	4–8 Hours	24–48 Hours (Two steps)
Moisture Sensitivity	High (Pyrophoric reagent)	Moderate	High (Imidate hydrolysis risk)
Yield (Typical)	75–95%	60–85%	40–70%
Atom Economy	Moderate (Al waste)	Low (PO byproduct)	Moderate

Troubleshooting & Optimization

- Problem: Low yield in AlMe3 reaction.
 - Root Cause:[\[3\]](#)[\[4\]](#)[\[5\]](#)[\[6\]](#)[\[7\]](#)[\[8\]](#) Incomplete formation of the Al-amine complex or moisture ingress.
 - Solution: Increase AlMe3 to 1.5 equiv and ensure the initial evolution of methane ceases before adding the nitrile. Use fresh anhydrous toluene.
- Problem: Hydrolysis of product during workup (POCl3 method).
 - Root Cause:[\[3\]](#)[\[4\]](#)[\[5\]](#)[\[6\]](#)[\[7\]](#)[\[8\]](#) Acetimidamides are basic and can hydrolyze back to amides in acidic/aqueous media.
 - Solution: Keep the workup pH > 9. Perform extraction quickly. Dry organic layers thoroughly.
- Problem: "Sticky" Aluminum emulsion during quench.
 - Solution: Use a saturated solution of Rochelle's salt (Potassium Sodium Tartrate) and stir vigorously for 1 hour. This chelates the aluminum, allowing clear phase separation.

Safety & Hazards

- Trimethylaluminum (AlMe₃):EXTREME HAZARD. Pyrophoric. Ignites spontaneously in air. Must be handled under inert atmosphere (Glovebox or Schlenk line). Have a bucket of dry sand nearby. Do not use water to extinguish.
- Phosphoryl Chloride (POCl₃): Reacts violently with water to release HCl and phosphoric acid. Corrosive and toxic by inhalation.
- Acetonitrile: Toxic if swallowed or inhaled (metabolizes to cyanide).

References

- Korbadi, B. L., & Lee, S. H. (2013).[9] Simple and Efficient Procedure for Synthesis of N'-Arylamidines Using Trimethylaluminum.[1][9] Bulletin of the Korean Chemical Society, 34(4), 1266–1268. [Link](#)
- Dunn, P. J. (2011). Amidines and Guanidines in Medicinal Chemistry. In Comprehensive Medicinal Chemistry II. Elsevier. [Link](#)
- Pinner, A., & Klein, F. (1877).[3][5][10] Umwandlung der Nitrile in Imide.[11] Berichte der deutschen chemischen Gesellschaft, 10(2), 1889–1897.[3][11] (Classic Reference for Pinner Chemistry).[2]
- Organic Chemistry Portal. (2024). Synthesis of Amidines. [Link](#)

Need Custom Synthesis?

BenchChem offers custom synthesis for rare earth carbides and specific isotopic labeling.

Email: info@benchchem.com or [Request Quote Online](#).

Sources

- [1. researchgate.net](https://www.researchgate.net) [[researchgate.net](https://www.researchgate.net)]
- [2. pdf.benchchem.com](https://pdf.benchchem.com) [pdf.benchchem.com]
- [3. jk-sci.com](https://www.jk-sci.com) [[jk-sci.com](https://www.jk-sci.com)]

- [4. scholarsbank.uoregon.edu \[scholarsbank.uoregon.edu\]](https://scholarsbank.uoregon.edu)
- [5. Pinner reaction - Wikipedia \[en.wikipedia.org\]](https://en.wikipedia.org)
- [6. CN101429153A - Synthesis of N- alkyl substituted maleimide - Google Patents \[patents.google.com\]](https://patents.google.com)
- [7. Synthesis of N-Aryl Amides by Ligand-Free Copper-Catalyzed ipso-Amidation of Arylboronic Acids with Nitriles \[organic-chemistry.org\]](https://organic-chemistry.org)
- [8. openaccesspub.org \[openaccesspub.org\]](https://openaccesspub.org)
- [9. semanticscholar.org \[semanticscholar.org\]](https://semanticscholar.org)
- [10. A Lewis acid-promoted Pinner reaction - PMC \[pmc.ncbi.nlm.nih.gov\]](https://pubmed.ncbi.nlm.nih.gov)
- [11. synarchive.com \[synarchive.com\]](https://synarchive.com)
- To cite this document: BenchChem. [Application Note: Strategic Reagents for the Synthesis of N-Substituted Acetimidamides]. BenchChem, [2026]. [Online PDF]. Available at: [\[https://www.benchchem.com/product/b1627592/docs#application-note-strategic-reagents-for-the-synthesis-of-n-substituted-acetimidamides\]](https://www.benchchem.com/product/b1627592/docs#application-note-strategic-reagents-for-the-synthesis-of-n-substituted-acetimidamides)

Disclaimer & Data Validity:

The information provided in this document is for Research Use Only (RUO) and is strictly not intended for diagnostic or therapeutic procedures. While BenchChem strives to provide accurate protocols, we make no warranties, express or implied, regarding the fitness of this product for every specific experimental setup.

Technical Support: The protocols provided are for reference purposes. Unsure if this reagent suits your experiment?

Need Industrial/Bulk Grade? [Request Custom Synthesis Quote](#)

BenchChem

Our mission is to be the trusted global source of essential and advanced chemicals, empowering scientists and researchers to drive progress in science and industry.

Contact

Address: 3281 E Guasti Rd
Ontario, CA 91761, United States
Phone: (601) 213-4426
Email: info@benchchem.com

Contact our Ph.D. Support Team for a compatibility check