

# Technical Support Guide: 3-Cyano-4-nitropyridine (CAS: 11874-81-0)

**Author:** BenchChem Technical Support Team. **Date:** May 2026

## Compound of Interest

Compound Name: 3-Cyano-4-nitropyridine

CAS No.: 1003711-76-9

Cat. No.: B1626991

[Get Quote](#)

## Introduction: Compound Profile

**3-Cyano-4-nitropyridine** (also known as 4-nitro-3-pyridinecarbonitrile) is a high-value heterocyclic intermediate, primarily used as a scaffold in the synthesis of kinase inhibitors and other bioactive pyridine derivatives.

Its chemical utility stems from the 4-nitro group, which acts as an excellent leaving group for Nucleophilic Aromatic Substitution (

), activated by both the pyridine nitrogen and the electron-withdrawing cyano group at the 3-position. However, this same reactivity profile necessitates rigorous safety protocols to prevent runaway exotherms and toxic release events.

Property	Specification
CAS Number	11874-81-0
Molecular Formula	
Molecular Weight	149.11 g/mol
Appearance	Pale yellow to yellow crystalline solid
Storage Condition	2-8°C, Inert Atmosphere (Argon/Nitrogen)
Primary Hazards	Acute Toxicity (Oral/Dermal), Skin Sensitizer, Reactive (High Energy)

## Module 1: Critical Safety & Handling Protocols

WARNING: This compound possesses a "Dual-Hazard" profile:

- **Energetic Instability:** The nitro group on an electron-deficient ring renders the compound susceptible to rapid thermal decomposition.
- **Cyanide Potential:** Under acidic conditions or thermal stress, the cyano moiety may release hydrogen cyanide (HCN) or toxic nitrogen oxides ( ).

### FAQ: Exposure & Emergency Response

Q: What is the immediate protocol for a spill outside the fume hood? A: Do not attempt to sweep dry dust.

- **Evacuate:** Clear the immediate area (radius 5m) to prevent inhalation of dust.
- **PPE Upgrade:** Response team must wear Tyvek suits and P100/N95 respiratory protection (or SCBA for large quantities >50g).
- **Neutralization:** Cover the spill with a wet absorbent pad (propylene glycol or water-dampened sand) to prevent dust aerosolization.

- Disposal: Collect into a sealed container labeled "Toxic Organic Waste." DO NOT use acidic cleaning agents (risk of HCN evolution).

Q: Can I store this compound on a standard chemical shelf? A:No.

- Temperature: Must be stored at 2-8°C. Room temperature storage accelerates the degradation of the nitro group, leading to pressure buildup in sealed vials.
- Atmosphere: Store under Argon or Nitrogen. Moisture initiates hydrolysis of the nitrile group to an amide, which is a common impurity source.

## Visual Guide: Safe Handling Decision Tree

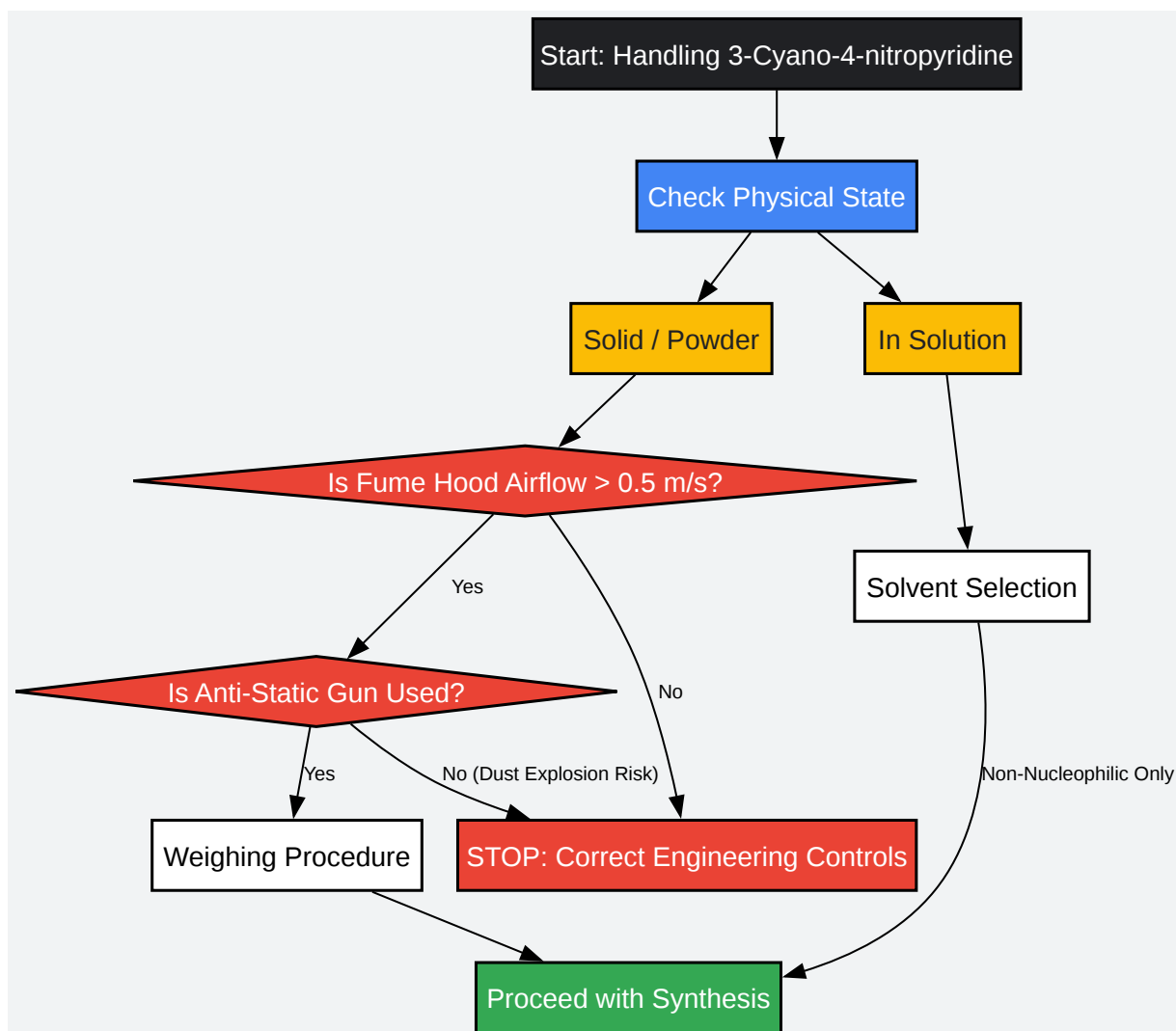

[Click to download full resolution via product page](#)

Figure 1: Decision logic for safe handling. Note the critical check for static dissipation due to the shock-sensitivity potential of dry nitro-heterocycles.

## Module 2: Reaction Troubleshooting (Synthesis & Scale-Up)

This section addresses common failures when using **3-Cyano-4-nitropyridine** as an electrophile in

reactions.

### Troubleshooting Table: Common Synthetic Failures

Symptom	Probable Cause	Corrective Action	Mechanism Ref
Reaction turns black/tarry immediately	Exothermic Decomposition. The nitro group is thermally unstable; the reaction temperature is too high.	Cool reaction to -10°C before adding nucleophile. Add nucleophile dropwise.	Nitro-group lability [1]
Low Yield (<40%)	Hydrolysis. Moisture in solvent is hydrolyzing the -CN group to -CONH <sub>2</sub> (amide).	Use anhydrous solvents (THF, DMF, MeCN) and molecular sieves.	Nitrile hydrolysis [2]
No Reaction (SM Recovery)	Weak Nucleophile. The 4-nitro group is reactive, but requires a base to scavenge the leaving group ( ).	Add a non-nucleophilic base (DIPEA, ). Ensure nucleophile is deprotonated.	Activation [3]
Unexpected By-product (M+16)	Oxidation. Formation of Pyridine N-Oxide during workup.	Avoid strong oxidizers during workup. Check purity of starting material.	N-Oxidation [4]

### FAQ: Process Optimization

Q: Which solvents are incompatible with this compound? A: Avoid nucleophilic solvents (e.g., Alcohols, Water, Primary Amines) unless they are the intended reactant. The 4-nitro position is so electrophilic that methanol or ethanol will displace the nitro group even at mild temperatures, forming the methoxy/ethoxy ether impurity.

- Recommended: Dichloromethane (DCM), Tetrahydrofuran (THF), Acetonitrile (MeCN).
- Avoid: MeOH, EtOH, Water (unless intended).

Q: How do I quench the reaction safely? A: The leaving group is the nitrite ion (

).

Upon quenching with acid, this can form nitrous acid (

), which is unstable.

- Protocol: Quench into a biphasic mixture of saturated aqueous

and organic solvent. This keeps the nitrite solubilized in the aqueous layer and prevents the formation of

gases.

Visual Guide:

Reaction Logic

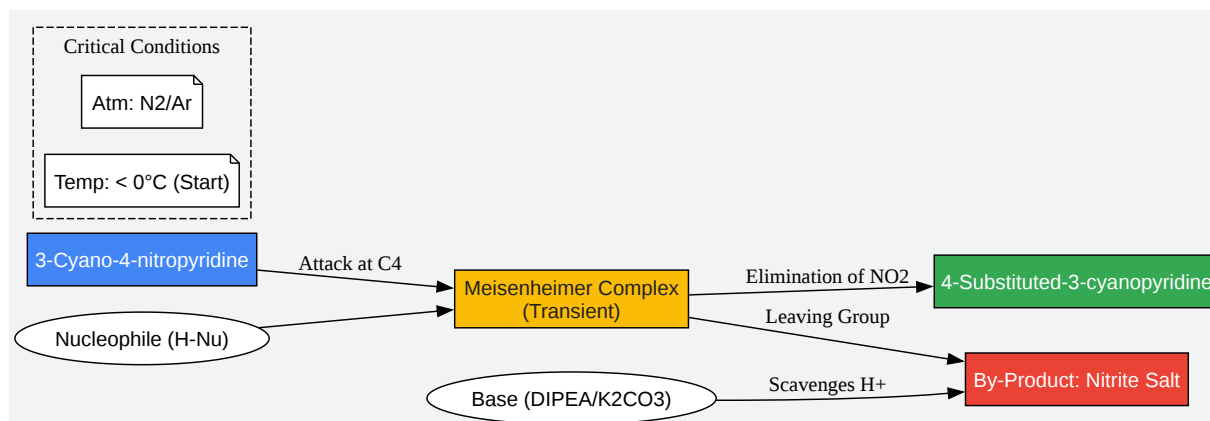

[Click to download full resolution via product page](#)

Figure 2: Mechanistic pathway for Nucleophilic Aromatic Substitution ( ) on the pyridine ring. Control of the intermediate complex is temperature-dependent.

## Module 3: Waste & Disposal

Q: Can this go into general organic waste? A: Absolutely NOT.

- Segregation: It must be segregated into "Cyanide-Contaminated" or "High Hazard" waste streams depending on facility regulations.
- pH Control: Ensure the waste container is kept basic (pH > 10).
  - Reasoning: If the waste stream becomes acidic, any liberated cyanide ions (from nitrile hydrolysis or degradation) will form Hydrogen Cyanide (HCN) gas, which is lethal.
- Labeling: Clearly mark containers: "Contains Nitropyridines & Cyanides - DO NOT ACIDIFY."

## References

- PubChem.4-Nitropyridine Properties and Stability. National Library of Medicine. Available at: [\[Link\]](#)
- Sigma-Aldrich. \*
- To cite this document: BenchChem. [Technical Support Guide: 3-Cyano-4-nitropyridine (CAS: 11874-81-0)]. BenchChem, [2026]. [Online PDF]. Available at: [\[https://www.benchchem.com/product/b1626991/docs#technical-support-guide-3-cyano-4-nitropyridine-cas-11874-81-0\]](https://www.benchchem.com/product/b1626991/docs#technical-support-guide-3-cyano-4-nitropyridine-cas-11874-81-0)

---

### Disclaimer & Data Validity:

The information provided in this document is for Research Use Only (RUO) and is strictly not intended for diagnostic or therapeutic procedures. While BenchChem strives to provide accurate protocols, we make no warranties, express or implied, regarding the fitness of this product for every specific experimental setup.

**Technical Support:** The protocols provided are for reference purposes. Unsure if this reagent suits your experiment?

**Need Industrial/Bulk Grade?** [Request Custom Synthesis Quote](#)

## BenchChem

Our mission is to be the trusted global source of essential and advanced chemicals, empowering scientists and researchers to drive progress in science and industry.

### Contact

Address: 3281 E Guasti Rd  
Ontario, CA 91761, United States  
Phone: (601) 213-4426  
Email: [info@benchchem.com](mailto:info@benchchem.com)

[Contact our Ph.D. Support Team for a compatibility check](#)

