

Spectroscopic Profiling & Comparative Analysis: 2-(4-(Dimethylamino)phenyl)acetaldehyde

Author: BenchChem Technical Support Team. **Date:** April 2026

Compound of Interest

Compound Name:	2-(4-(Dimethylamino)phenyl)acetaldehyde
CAS No.:	99074-89-2
Cat. No.:	B1626677

[Get Quote](#)

Executive Summary

2-(4-(Dimethylamino)phenyl)acetaldehyde (referred to herein as DAPA) presents a unique spectroscopic profile that is frequently misinterpreted due to its structural similarity to the widely used 4-(dimethylamino)benzaldehyde (DAB).

While DAB exhibits a strong Intramolecular Charge Transfer (ICT) band in the visible region (appearing bright yellow), DAPA is effectively "insulated" by a methylene (

) bridge. This bridge breaks the conjugation between the electron-donating dimethylamino group and the electron-withdrawing aldehyde. Consequently, DAPA behaves spectroscopically like a substituted aniline, absorbing primarily in the UV region, and is colorless to pale yellow in its pure form.

Key Application Insight: Researchers utilizing DAPA as a metabolic probe or synthetic intermediate must rely on UV absorption (

) rather than visible colorimetry. Appearance of a strong yellow/orange color often indicates degradation to conjugated impurities or Schiff base formation.

Structural Basis of Absorption (The "Broken Conjugation" Effect)

To interpret the spectra correctly, one must understand the electronic connectivity.

- DAB (Comparator): The carbonyl is directly attached to the phenyl ring. The -electrons flow from the Nitrogen lone pair, through the ring, to the Carbonyl oxygen. This "Push-Pull" system lowers the energy gap, shifting absorption to (Visible/Blue absorption Yellow color).
- DAPA (Target): The methylene group acts as an electronic insulator. The -system of the phenyl ring is not conjugated with the carbonyl. The spectrum is essentially a superposition of N,N-dimethyl-p-toluidine and an isolated aldehyde.

Diagram: Electronic Conjugation Logic

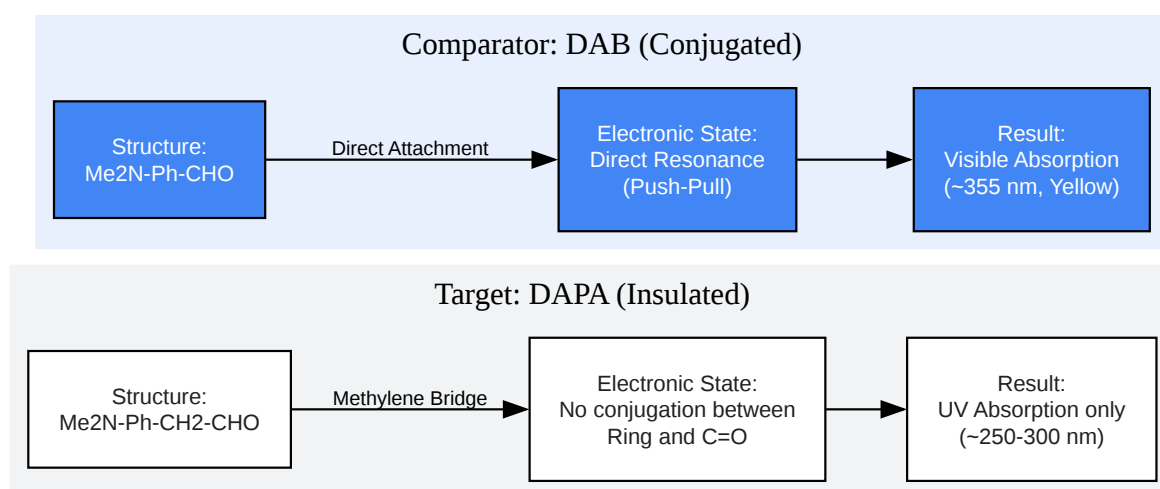

[Click to download full resolution via product page](#)

Caption: Comparison of electronic connectivity. The methylene bridge in DAPA prevents the long-wavelength shift seen in DAB.

Comparative Spectral Data

The following table contrasts DAPA with its direct structural analogs. This data is critical for quality control and identifying oxidation products.

Compound	Structure	(Solvent: EtOH/MeOH)	Visual Appearance	Electronic Origin
DAPA		~250 nm (Strong)~299 nm (Secondary)	Colorless / Pale Oil	Benzenoid (Similar to Toluidine)
DAB (Ref)		355 nm	Bright Yellow Solid	Strong ICT (Donor Acceptor)
DACA (Ref)		398 nm	Orange/Red Solid	Extended Conjugation
Acid Impurity		~255 nm	White Solid	Similar to DAPA (No conjugation)

Note on Solvatochromism:

- DAB shows significant solvatochromism (peak shifts with solvent polarity) due to its large dipole moment change upon excitation.[1]
- DAPA shows minimal solvatochromism because the ground and excited states are less polarized relative to each other.

Experimental Protocol: Stability & Measurement

DAPA is chemically unstable.[2] It is prone to trimerization (forming a trioxane) and oxidation (forming phenylacetic acid) upon exposure to air. The following protocol ensures data integrity.

Reagents

- Solvent: Acetonitrile (MeCN) is preferred over Ethanol for storage, as Ethanol can form hemiacetals with the aldehyde, altering the spectrum.
- Blank: Pure solvent.

Step-by-Step Workflow

- Fresh Preparation (Critical):
 - Do not use stock solutions stored for >24 hours.
 - Weigh ~10 mg of DAPA in a glovebox or under flow.
 - Dissolve in MeCN to reach 1 mM concentration.
- Dilution:
 - Dilute to ~10-50 M for UV analysis. (Target Absorbance: 0.5 - 0.8 AU).
- Scan Parameters:
 - Range: 200 nm to 500 nm.
 - Scan Speed: Medium (avoid fast scans to ensure resolution of the ~300 nm shoulder).
- Quality Control Check:
 - Pass: Spectrum shows distinct peaks at ~250 nm and ~300 nm. Baseline at >350 nm is near zero.
 - Fail (Oxidation): Loss of the aldehyde proton peak in NMR (check if available). UV spectrum remains similar, but melting point increases (Acid mp > Aldehyde mp).

- Fail (Schiff Base): Appearance of a new peak >330 nm indicates reaction with amine impurities or solvent contaminants.

Diagram: QC & Measurement Workflow

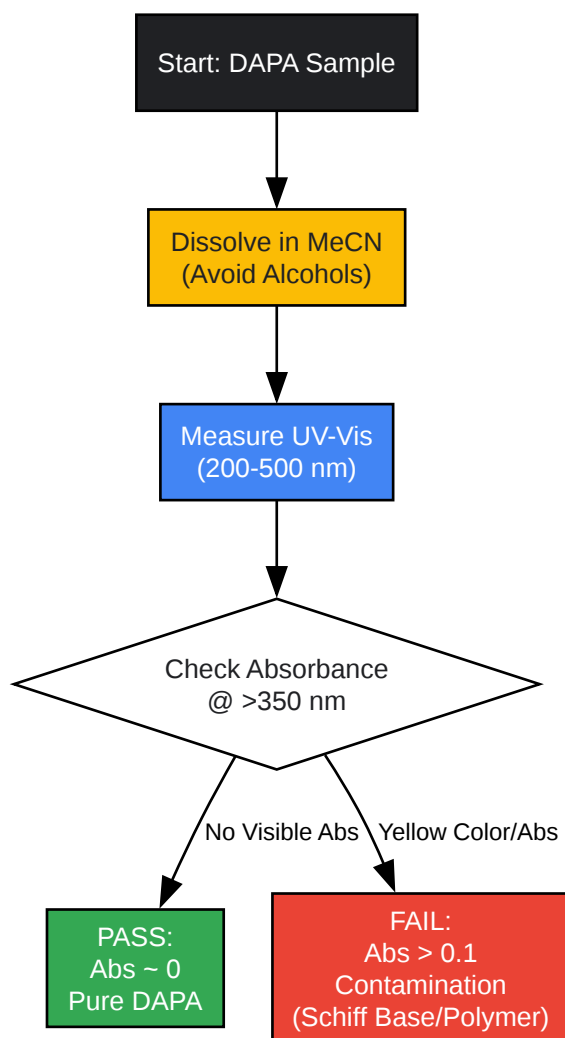

[Click to download full resolution via product page](#)

Caption: Decision tree for validating DAPA purity via UV-Vis spectroscopy.

References

- BenchChem. (2025).^{[1][3][4][5]} Comparative Guide: 4-[4-(Dimethylamino)phenyl]benzaldehyde vs. 4-dimethylaminobenzaldehyde. Retrieved from

- NIST Chemistry WebBook. (2025). UV/Vis Database: N,N-Dimethyl-p-toluidine and related aromatics. Retrieved from [6]
- Sigma-Aldrich. (2025). Product Specification: 4-(Dimethylamino)benzaldehyde. Retrieved from
- PubChem. (2025). Compound Summary: **2-(4-(Dimethylamino)phenyl)acetaldehyde**. [7] Retrieved from
- Thermo Fisher Scientific. (2025). Application Note: Determination of Toluidine Derivatives by UV Absorbance. Retrieved from

Need Custom Synthesis?

BenchChem offers custom synthesis for rare earth carbides and specific isotopic labeling.

Email: info@benchchem.com or [Request Quote Online](#).

Sources

- 1. pdf.benchchem.com [pdf.benchchem.com]
- 2. datasheets.scbt.com [datasheets.scbt.com]
- 3. pdf.benchchem.com [pdf.benchchem.com]
- 4. pdf.benchchem.com [pdf.benchchem.com]
- 5. benchchem.com [benchchem.com]
- 6. 2-Propenal, 3-[4-(dimethylamino)phenyl]- [webbook.nist.gov]
- 7. 2-(4-(DIMETHYLAMINO)PHENYL)ACETALDEHYDE | 99074-89-2 [chemicalbook.com]
- To cite this document: BenchChem. [Spectroscopic Profiling & Comparative Analysis: 2-(4-(Dimethylamino)phenyl)acetaldehyde]. BenchChem, [2026]. [Online PDF]. Available at: [<https://www.benchchem.com/product/b1626677/docs#spectroscopic-profiling-comparative-analysis-2-4-dimethylamino-phenyl-acetaldehyde>]

Disclaimer & Data Validity:

The information provided in this document is for Research Use Only (RUO) and is strictly not intended for diagnostic or therapeutic procedures. While BenchChem strives to provide accurate protocols, we make no warranties, express or implied, regarding the fitness of this product for every specific experimental setup.

Technical Support: The protocols provided are for reference purposes. Unsure if this reagent suits your experiment?

Need Industrial/Bulk Grade? [Request Custom Synthesis Quote](#)

BenchChem

Our mission is to be the trusted global source of essential and advanced chemicals, empowering scientists and researchers to drive progress in science and industry.

Contact

Address: 3281 E Guasti Rd
Ontario, CA 91761, United States
Phone: (601) 213-4426
Email: info@benchchem.com

[Contact our Ph.D. Support Team for a compatibility check](#)