

High-Resolution HPLC Separation of Nitroimidazole Isomers: A Comparative Method Development Guide

Author: BenchChem Technical Support Team. **Date:** April 2026

Compound of Interest

Compound Name:	4-Chloro-1-methyl-2-nitro-1H-imidazole
CAS No.:	63634-20-8
Cat. No.:	B1626695

[Get Quote](#)

Introduction: The "Polarity Trap" in Nitroimidazole Analysis

Nitroimidazoles—including Metronidazole (MNZ), Tinidazole (TNZ), and their synthesis intermediates like 2-methyl-5-nitroimidazole (2-MNI)—present a unique chromatographic challenge. They are small, relatively polar, and possess basic nitrogen centers that are prone to silanol interactions.

The critical difficulty lies in isomer resolution. During synthesis, the nitration of imidazoles can yield both 4-nitro and 5-nitro isomers. While unsubstituted 4- and 5-nitroimidazoles exist in tautomeric equilibrium (making them inseparable), N-substituted derivatives (like the drugs themselves) are fixed regioisomers. Separating the active 5-nitro drug from the inactive or toxic 4-nitro impurity requires selectivity that standard C18 columns often fail to provide due to the compounds' identical hydrophobicity.

This guide moves beyond the standard USP monographs to compare modern stationary phase chemistries, demonstrating why Fluorophenyl (PFP) phases often outperform traditional C18 for this specific class of analytes.

Comparative Analysis: C18 vs. PFP vs. HILIC[1]

We evaluated three distinct separation modes for a mixture containing Metronidazole (MNZ), its impurity 2-methyl-5-nitroimidazole (2-MNI), and a structural isomer analog.

Table 1: Performance Comparison of Stationary Phases

Feature	Method A: Traditional C18	Method B: Fluorophenyl (PFP)	Method C: HILIC (Silica)
Column Type	End-capped C18 (3 μ m)	Pentafluorophenyl Propyl (3 μ m)	Bare Silica or Zwitterionic
Mechanism	Hydrophobic Interaction	Hydrophobic + - Interaction + Dipole	Hydrophilic Partitioning
Mobile Phase	Water/MeOH (Phosphate Buffer)	Water/MeOH (Formate/Acetate)	ACN/Water (Ammonium Formate)
Retention (k')	Low to Moderate (k' ~ 1-3)	Moderate to High (k' ~ 2-5)	High (k' > 5 for polars)
Isomer Selectivity ()	Low (Often co-elute)	High (Resolves nitro-positions)	Moderate
Peak Shape	Prone to tailing (Silanol effects)	Excellent (Rigid ligand structure)	Good (buffer dependent)
Best Use Case	Routine Potency Assay	Impurity Profiling & Isomers	Ultra-polar Metabolites

Deep Dive: Why PFP Wins for Nitroimidazoles

While C18 relies solely on hydrophobicity, PFP phases possess a fluorine ring that is highly electron-deficient. The nitro group (

) on the imidazole ring is electron-withdrawing, but the overall dipole and electron cloud distribution differ significantly between the 4-nitro and 5-nitro isomers.

- The Mechanism: The PFP phase engages in strong

-

interactions and dipole-dipole interactions with the nitroimidazole ring. These interactions are highly sensitive to the position of the nitro group, providing the necessary thermodynamic difference (

) to resolve isomers that have identical LogP values.

Validated Experimental Protocols

Protocol A: The "Gold Standard" PFP Method for Isomer Resolution

Recommended for separating 4-nitro vs 5-nitro isomers and related impurities.

Reagents:

- HPLC Grade Methanol (MeOH)
- Ammonium Formate (10 mM)[1]
- Formic Acid[2][3][4][5]

Step-by-Step Workflow:

- Mobile Phase Preparation:
 - Solvent A: 10 mM Ammonium Formate in Water, adjusted to pH 3.0 with Formic Acid. (Low pH suppresses silanol activity and ensures the imidazole nitrogen is protonated,).

- Solvent B: 100% Methanol.
- Column Equilibration:
 - Install a PFP column (e.g., 150 x 4.6 mm, 3 μ m).
 - Flush with 50:50 A:B for 30 mins, then equilibrate at initial conditions.
- Gradient Profile:
 - T=0 min: 5% B (High aqueous start is crucial for retention of polar 2-MNI).
 - T=5 min: 5% B (Isocratic hold to resolve early eluters).
 - T=15 min: 30% B (Linear ramp).
 - T=20 min: 30% B.
- Detection: UV at 315-320 nm (Nitroimidazoles have a distinct max here, reducing background noise from non-nitro impurities).

Protocol B: System Suitability Criteria (Self-Validating)

To ensure the method is trustworthy, every run must pass these criteria:

- Resolution ():
between Metronidazole and 2-methyl-5-nitroimidazole.
- Tailing Factor ():
(If , increase buffer concentration to 20mM).
- Precision: RSD

for retention time (n=6).

Visualizing the Logic

Diagram 1: Method Development Decision Tree

This logic flow guides you from analyte structure to the correct column choice, preventing wasted time on C18 optimization when it is structurally incapable of the separation.

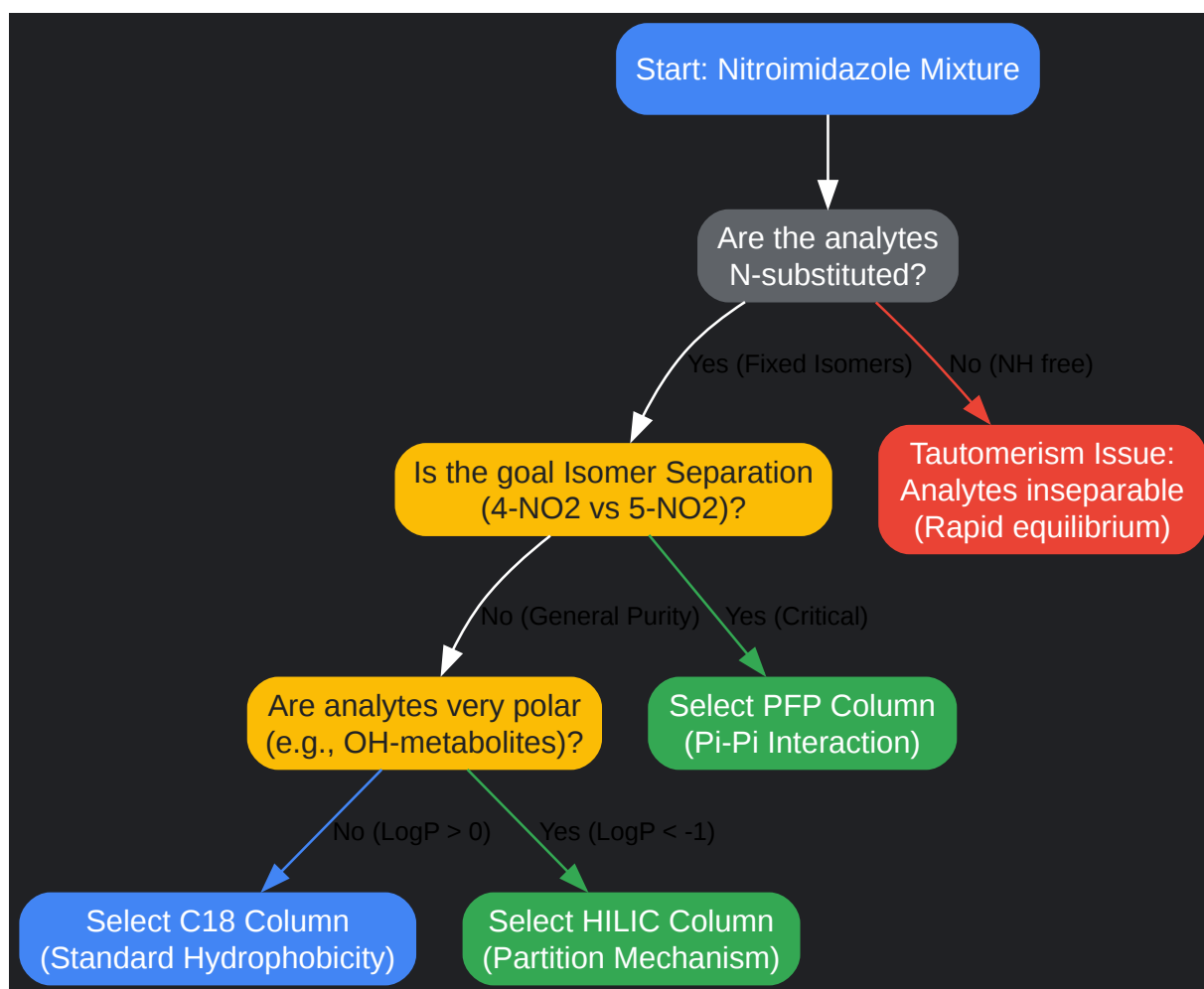

[Click to download full resolution via product page](#)

Caption: Decision matrix for selecting the optimal stationary phase based on structural properties.

Diagram 2: The Separation Mechanism (PFP vs. C18)

Understanding why PFP works is key to troubleshooting. This diagram illustrates the dual-interaction mechanism.

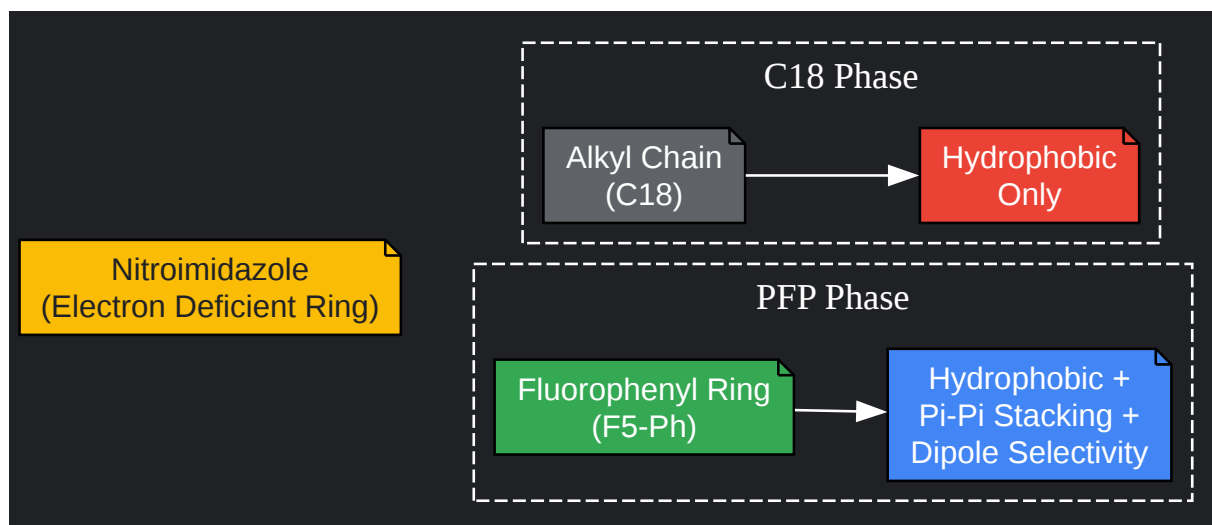

[Click to download full resolution via product page](#)

Caption: PFP phases offer multi-modal retention (Pi-Pi + Dipole) compared to the single mode of C18.

Troubleshooting & Optimization

- **Peak Tailing:** Nitroimidazoles are basic. If tailing occurs on C18, add 0.1% Triethylamine (TEA) to the mobile phase (if using phosphate buffer) or switch to a "Polar Embedded" C18 which shields silanols.
- **Retention Drift:** These compounds are pH-sensitive. Ensure the buffer capacity is sufficient. A 10mM buffer is the minimum; 25mM is preferred for robustness.
- **Dewetting:** If using a standard C18 with >95% water (required for retaining polar impurities like 2-MNI), the phase may "collapse" (dewet). Solution: Use a "C18-Aq" (aqueous compatible) column or the PFP column recommended above, which tolerates 100% aqueous conditions well.

References

- National Center for Biotechnology Information (2025). PubChem Compound Summary for CID 4173, Metronidazole. Retrieved from [\[Link\]](#)
- Bozhanov, S. et al. (2018). Simultaneous Determination of Some 5-Nitroimidazole Derivatives and Ciprofloxacin by High Performance Liquid Chromatography. [\[6\]](#) Indian Journal of Pharmaceutical Education and Research. [\[6\]](#) Retrieved from [\[Link\]](#)
- SIELC Technologies. HPLC Method for Analysis of Mixture of Nitroimidazole Antibiotics on Newcrom Type Columns. Retrieved from [\[Link\]](#)
- Waters Corporation. Selectivity Differences Between Three C18 Columns and the Impact Upon Preparative Separations. Retrieved from [\[Link\]](#)
- Mac-Mod Analytical. Exploring the Selectivity of C18 Phases with Phenyl and PFP Functionality. Retrieved from [\[Link\]](#)

Need Custom Synthesis?

BenchChem offers custom synthesis for rare earth carbides and specific isotopic labeling.

Email: info@benchchem.com or [Request Quote Online](#).

Sources

- [1. chromatographyonline.com](https://www.chromatographyonline.com) [[chromatographyonline.com](https://www.chromatographyonline.com)]
- [2. \[Analytical Method for Nitroimidazoles and Their Major Metabolites in Livestock and Fishery Products Using LC-MS/MS\] - PubMed](https://pubmed.ncbi.nlm.nih.gov/) [pubmed.ncbi.nlm.nih.gov]
- [3. researchgate.net](https://www.researchgate.net) [[researchgate.net](https://www.researchgate.net)]
- [4. Separation of Benzimidazole, 2-methyl-5-nitro- on Newcrom R1 HPLC column | SIELC Technologies](https://www.sielc.com) [[sielc.com](https://www.sielc.com)]
- [5. lcms.cz](https://www.lcms.cz) [[lcms.cz](https://www.lcms.cz)]
- [6. ijper.org](https://www.ijper.org) [[ijper.org](https://www.ijper.org)]
- To cite this document: BenchChem. [High-Resolution HPLC Separation of Nitroimidazole Isomers: A Comparative Method Development Guide]. BenchChem, [2026]. [Online PDF]. Available at: [<https://www.benchchem.com/product/b1626695/docs#high-resolution-hplc-separation-of-nitroimidazole-isomers-a-comparative-method-development-guide>]

Disclaimer & Data Validity:

The information provided in this document is for Research Use Only (RUO) and is strictly not intended for diagnostic or therapeutic procedures. While BenchChem strives to provide accurate protocols, we make no warranties, express or implied, regarding the fitness of this product for every specific experimental setup.

Technical Support: The protocols provided are for reference purposes. Unsure if this reagent suits your experiment?

Need Industrial/Bulk Grade? [Request Custom Synthesis Quote](#)

BenchChem

Our mission is to be the trusted global source of essential and advanced chemicals, empowering scientists and researchers to drive progress in science and industry.

Contact

Address: 3281 E Guasti Rd
Ontario, CA 91761, United States
Phone: (601) 213-4426
Email: info@benchchem.com

[Contact our Ph.D. Support Team for a compatibility check](#)