

Technical Support Center: Ortho-Selective Benzene Alkylation with Chlorocyclohexane

Author: BenchChem Technical Support Team. **Date:** May 2026

Compound of Interest

Compound Name: 1-Chloro-2-cyclohexylbenzene

CAS No.: 91766-85-7

Cat. No.: B1625857

[Get Quote](#)

Welcome to the technical support center for navigating the complexities of Friedel-Crafts alkylation, specifically focusing on enhancing the ortho-selectivity in the reaction between benzene and chlorocyclohexane. This guide is designed for researchers, scientists, and drug development professionals who are looking to optimize this crucial C-C bond-forming reaction. Here, we will delve into the mechanistic underpinnings, troubleshoot common experimental hurdles, and provide actionable protocols to steer your synthesis towards the desired ortho-isomer.

Frequently Asked Questions (FAQs)

Q1: What is the fundamental mechanism of the Friedel-Crafts alkylation of benzene with chlorocyclohexane?

The Friedel-Crafts alkylation is a classic example of an electrophilic aromatic substitution reaction.^[1] In this process, a Lewis acid catalyst, typically aluminum chloride (AlCl_3), facilitates the formation of a cyclohexyl carbocation from chlorocyclohexane.^{[2][3][4]} This electrophilic carbocation is then attacked by the electron-rich π -system of the benzene ring, leading to the formation of a resonance-stabilized carbocation intermediate known as an arenium ion or

sigma complex.[1][3][5] Finally, a weak base, such as the AlCl_4^- complex, abstracts a proton from the ring, restoring aromaticity and yielding the alkylated benzene product, cyclohexylbenzene.[3][4]

Q2: Why is achieving high ortho-selectivity a challenge in this reaction?

Statistically, a benzene ring has two ortho positions and one para position available for substitution. This would suggest a 2:1 ratio of ortho to para products.[6] However, the reality is more complex. Several factors influence the final isomer distribution:

- **Steric Hindrance:** The bulky cyclohexyl group encounters significant steric hindrance at the ortho positions, which are adjacent to the point of attachment. The para position, being less sterically crowded, is often the favored site of attack.[7][8]
- **Electronic Effects:** Alkyl groups are weakly activating and are known as ortho, para-directors. [7][9][10] They donate electron density to the benzene ring, stabilizing the carbocation intermediates formed during substitution at these positions.[11]
- **Thermodynamic vs. Kinetic Control:** The ortho-isomer is often the kinetically favored product, forming faster at lower temperatures. However, it can be less stable than the para-isomer. Under conditions that allow for equilibrium (higher temperatures, longer reaction times), the product distribution may shift towards the more thermodynamically stable para-isomer.

Q3: How does the choice of Lewis acid catalyst impact the ortho/para ratio?

The Lewis acid plays a pivotal role in not only catalyzing the reaction but also influencing its regioselectivity. The size and nature of the Lewis acid can affect the steric environment around the electrophile. Larger, bulkier Lewis acid complexes can further increase the steric hindrance at the ortho positions, thereby favoring the para product. Conversely, certain Lewis acids can engage in coordination effects that may favor ortho-substitution. For instance, some catalytic systems can involve interactions that pre-organize the reactants, directing the alkylation to the ortho position.[12][13][14]

Q4: Can reaction conditions be modified to favor the ortho-isomer?

Yes, manipulating the reaction conditions is a key strategy for enhancing ortho-selectivity.

Important parameters to consider include:

- Temperature: Lower reaction temperatures generally favor the kinetically controlled ortho-product.
- Solvent: The polarity of the solvent can influence the stability of the transition states leading to the different isomers. Non-polar solvents may favor ortho-alkylation in some systems.[\[13\]](#)
- Reaction Time: Shorter reaction times can help to isolate the kinetic product before significant isomerization to the more stable para-isomer occurs.

Troubleshooting Guide: Common Issues and Solutions

Issue	Potential Cause(s)	Recommended Solution(s)	Scientific Rationale
Low Overall Yield	1. Inactive catalyst (e.g., hydrolyzed AlCl_3).2. Insufficient reaction temperature or time.3. Presence of deactivating groups on the benzene ring (if using substituted benzenes). [5] [15]	1. Use freshly opened or sublimed AlCl_3 . Ensure anhydrous conditions.2. Gradually increase reaction temperature and monitor progress by TLC or GC.3. Friedel-Crafts alkylation is generally not suitable for strongly deactivated rings. [5] [15]	1. Lewis acids like AlCl_3 are highly moisture-sensitive. Hydrolysis deactivates the catalyst.2. The reaction has an activation energy barrier that must be overcome.3. Electron-withdrawing groups make the benzene ring less nucleophilic and less reactive towards electrophiles. [15]
Poor ortho/para Ratio (High Para Product)	1. High reaction temperature favoring the thermodynamic product.2. Steric hindrance from a bulky catalyst-electrophile complex.3. Extended reaction time allowing for isomerization.	1. Conduct the reaction at a lower temperature (e.g., 0 °C or below).2. Experiment with different Lewis acids (e.g., milder Lewis acids like ZnCl_2 or FeCl_3) or use a directing group strategy. [12] [16] 3. Monitor the reaction closely and quench it once the desired amount of ortho-product has formed.	1. The formation of the ortho-isomer often has a lower activation energy (kinetic control).2. Less bulky catalysts can reduce steric hindrance at the ortho positions. Directing groups can force the reaction to occur at the adjacent position. [16] 3. Over time, the initially formed ortho-isomer can rearrange to the more thermodynamically stable para-isomer.

Polyalkylation	The alkylated product (cyclohexylbenzene) is more reactive than benzene itself. [4] [5] [9]	1. Use a large excess of benzene relative to chlorocyclohexane.2. Add the chlorocyclohexane slowly to the reaction mixture.	1. A large excess of benzene increases the probability that the electrophile will react with a benzene molecule rather than an already alkylated product.2. Slow addition maintains a low concentration of the electrophile, minimizing the chance of multiple substitutions on the same ring.
Carbocation Rearrangement (if using a different alkyl halide)	Formation of a more stable carbocation from a less stable one. [5] [15]	Use Friedel-Crafts acylation followed by reduction to obtain the desired alkylbenzene.	The acylium ion formed during acylation is resonance-stabilized and does not undergo rearrangement. [17]

Visualizing the Reaction Pathway

The following diagram illustrates the general mechanism for the Friedel-Crafts alkylation of benzene, highlighting the formation of both ortho and para products.

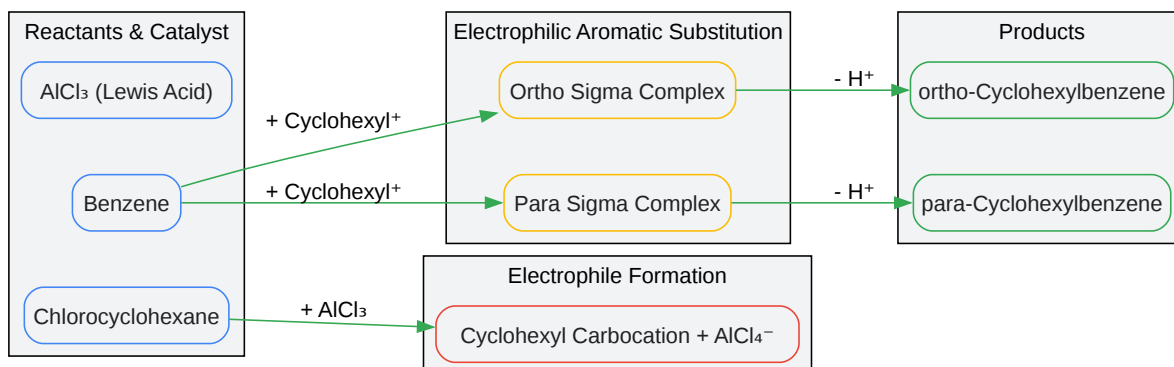

[Click to download full resolution via product page](#)

Caption: Friedel-Crafts alkylation of benzene with chlorocyclohexane.

Experimental Protocol: Maximizing Ortho-Selectivity

This protocol is a starting point for optimizing the ortho-selective alkylation of benzene with chlorocyclohexane.

Materials:

- Benzene (anhydrous)
- Chlorocyclohexane (freshly distilled)
- Aluminum chloride (anhydrous)
- Dry ice/acetone bath
- Nitrogen or argon gas for inert atmosphere
- Standard laboratory glassware (dried in an oven)

Procedure:

- **Setup:** Assemble a flame-dried, three-necked round-bottom flask equipped with a magnetic stirrer, a dropping funnel, a thermometer, and a nitrogen/argon inlet.
- **Initial Charge:** Charge the flask with anhydrous benzene (a significant excess, e.g., 10 equivalents) and cool the flask to 0 °C using an ice-water bath.
- **Catalyst Addition:** Under a positive pressure of inert gas, carefully and portion-wise add anhydrous aluminum chloride (e.g., 1.1 equivalents) to the stirred benzene.
- **Substrate Addition:** Once the catalyst has dissolved, begin the slow, dropwise addition of chlorocyclohexane (1 equivalent) from the dropping funnel. Maintain the internal temperature between 0 and 5 °C throughout the addition.
- **Reaction Monitoring:** After the addition is complete, continue stirring at 0-5 °C. Monitor the reaction progress by taking small aliquots and analyzing them by Gas Chromatography (GC) to determine the ortho/para ratio and the consumption of starting material.
- **Quenching:** Once the desired conversion and selectivity are achieved, slowly and carefully quench the reaction by pouring the mixture over crushed ice and dilute HCl. Caution: This is a highly exothermic process.
- **Workup:** Separate the organic layer, wash it with water, saturated sodium bicarbonate solution, and brine. Dry the organic layer over anhydrous magnesium sulfate or sodium sulfate.
- **Purification:** Remove the solvent under reduced pressure. The resulting crude product can be purified by fractional distillation or column chromatography to isolate the ortho-isomer.

References

- Mettler Toledo. Friedel-Crafts Alkylation Reaction. [[Link](#)]
- Quora. When a benzene ring with an ortho-para directing substituent undergoes an electrophilic aromatic substitution reaction, what percentage of the product is the ortho isomer and what percentage is the Para isomer? [[Link](#)]

- ChemRxiv. Catalytic Friedel–Crafts Reactions of Unactivated Secondary Alcohols: Site-Selective ortho-Alkylation of Phenols. [[Link](#)]
- ResearchGate. Catalytic Friedel–Crafts Reactions of Unactivated Secondary Alcohols: Site-Selective ortho-Alkylation of Phenols. [[Link](#)]
- YouTube. Alkylation of Benzene - Friedel Crafts (A-Level Chemistry). [[Link](#)]
- Chemguide. Explaining the Friedel-Crafts alkylation of benzene - electrophilic substitution. [[Link](#)]
- ACS Publications. Lewis Acid-Base Interaction-Controlled ortho-Selective C-H Borylation of Aryl Sulfides. [[Link](#)]
- Master Organic Chemistry. EAS Reactions (3) - Friedel-Crafts Acylation and Friedel-Crafts Alkylation. [[Link](#)]
- YouTube. Friedel Crafts Alkylation of Benzene Reaction Mechanism - Tons of Examples! [[Link](#)]
- Chemistry Steps. Ortho Para and Meta in Disubstituted Benzenes. [[Link](#)]
- Chemistry LibreTexts. 16.3: Alkylation and Acylation of Aromatic Rings - The Friedel-Crafts Reaction. [[Link](#)]
- Chemguide. the alkylation of benzene - electrophilic substitution. [[Link](#)]
- Master Organic Chemistry. Ortho-, Para- and Meta- Directors in Electrophilic Aromatic Substitution. [[Link](#)]
- Chemistry LibreTexts. The Friedel-Crafts Alkylation of Benzene. [[Link](#)]
- Wikipedia. Friedel–Crafts reaction. [[Link](#)]
- Dalal Institute. The Ortho/Para Ratio. [[Link](#)]
- Chemistry Steps. Ortho, Para, Meta. [[Link](#)]

Need Custom Synthesis?

BenchChem offers custom synthesis for rare earth carbides and specific isotopic labeling.

Email: info@benchchem.com or [Request Quote Online](#).

Sources

- [1. mt.com \[mt.com\]](https://mt.com)
- [2. m.youtube.com \[m.youtube.com\]](https://m.youtube.com)
- [3. chemguide.co.uk \[chemguide.co.uk\]](https://chemguide.co.uk)
- [4. chemguide.co.uk \[chemguide.co.uk\]](https://chemguide.co.uk)
- [5. chem.libretexts.org \[chem.libretexts.org\]](https://chem.libretexts.org)
- [6. quora.com \[quora.com\]](https://quora.com)
- [7. masterorganicchemistry.com \[masterorganicchemistry.com\]](https://masterorganicchemistry.com)
- [8. dalalinstitute.com \[dalalinstitute.com\]](https://dalalinstitute.com)
- [9. youtube.com \[youtube.com\]](https://youtube.com)
- [10. Ortho Para and Meta in Disubstituted Benzenes - Chemistry Steps \[chemistrysteps.com\]](https://chemistrysteps.com)
- [11. Ortho, Para, Meta - Chemistry Steps \[chemistrysteps.com\]](https://chemistrysteps.com)
- [12. chemrxiv.org \[chemrxiv.org\]](https://chemrxiv.org)
- [13. researchgate.net \[researchgate.net\]](https://researchgate.net)
- [14. Lewis Acid-Base Interaction-Controlled ortho-Selective C-H Borylation of Aryl Sulfides - PubMed \[pubmed.ncbi.nlm.nih.gov\]](https://pubmed.ncbi.nlm.nih.gov)
- [15. masterorganicchemistry.com \[masterorganicchemistry.com\]](https://masterorganicchemistry.com)
- [16. pdf.benchchem.com \[pdf.benchchem.com\]](https://pdf.benchchem.com)
- [17. Friedel–Crafts reaction - Wikipedia \[en.wikipedia.org\]](https://en.wikipedia.org)
- To cite this document: BenchChem. [Technical Support Center: Ortho-Selective Benzene Alkylation with Chlorocyclohexane]. BenchChem, [2026]. [Online PDF]. Available at: [\[https://www.benchchem.com/product/b1625857/docs#technical-support-center-ortho-selective-benzene-alkylation-with-chlorocyclohexane\]](https://www.benchchem.com/product/b1625857/docs#technical-support-center-ortho-selective-benzene-alkylation-with-chlorocyclohexane)

Disclaimer & Data Validity:

The information provided in this document is for Research Use Only (RUO) and is strictly not intended for diagnostic or therapeutic procedures. While BenchChem strives to provide accurate protocols, we make no warranties, express or implied, regarding the fitness of this product for every specific experimental setup.

Technical Support: The protocols provided are for reference purposes. Unsure if this reagent suits your experiment?

Need Industrial/Bulk Grade? [Request Custom Synthesis Quote](#)

BenchChem

Our mission is to be the trusted global source of essential and advanced chemicals, empowering scientists and researchers to drive progress in science and industry.

Contact

Address: 3281 E Guasti Rd
Ontario, CA 91761, United States
Phone: (601) 213-4426
Email: info@benchchem.com

[Contact our Ph.D. Support Team for a compatibility check](#)