

# UV-Vis Absorption Characteristics of Stilbene and Derivatives: A Comparative Technical Guide

**Author:** BenchChem Technical Support Team. **Date:** May 2026

## Compound of Interest

**Compound Name:** 2-[(E)-2-(4-Methylphenyl)ethenyl]pyridine

**CAS No.:** 718-27-4

**Cat. No.:** B1623112

[Get Quote](#)

## Executive Summary

Stilbene (1,2-diphenylethylene) serves as the fundamental scaffold for a vast array of optical brighteners, laser dyes, and photochromic switches. Its electronic absorption spectrum is governed by the extent of

-conjugation, which is modulated by geometric isomerism (cis vs. trans) and electronic substituents.

This guide provides a technical comparison of the UV-Vis absorption maxima (

) of trans-stilbene against its geometric isomer and functionalized derivatives. It details the mechanistic drivers behind bathochromic (red) and hypsochromic (blue) shifts and offers a validated experimental protocol for reproducible spectral acquisition.

## Fundamental Principles of Stilbene Chromophores

The UV-Vis spectrum of stilbene arises primarily from

electronic transitions. The energy gap (

) between the Highest Occupied Molecular Orbital (HOMO) and the Lowest Unoccupied Molecular Orbital (LUMO) dictates the absorption maximum according to the Planck relation

## Geometric Isomerism (cis vs. trans)

- Trans-Stilbene: Adopts a near-planar ( geometry, maximizing -orbital overlap between the vinyl bond and phenyl rings. This extended conjugation lowers the HOMO-LUMO gap, resulting in a lower energy (longer wavelength) transition.
- Cis-Stilbene: Steric repulsion between the phenyl rings forces a twisted geometry (dihedral angle  $\sim 30-40^\circ$ ). This torsion breaks effective conjugation, raising the transition energy and causing a hypsochromic (blue) shift and hypochromic effect (lower intensity) compared to the trans isomer.

## Electronic Substituent Effects

Substituents alter the frontier orbital energies:

- Auxochromes (e.g., -OH, -OCH ): Electron Donating Groups (EDG) raise the HOMO energy.
- Chromophores (e.g., -NO ): Electron Withdrawing Groups (EWG) lower the LUMO energy.
- Push-Pull Systems: Combining an EDG at one end and an EWG at the other creates a "push-pull" system. This facilitates Intramolecular Charge Transfer (ICT), drastically narrowing the bandgap and causing significant bathochromic (red) shifts.

## Comparative Analysis: Data[1][2][3][4][5][6]

The following table synthesizes experimental absorption maxima for trans-stilbene and key derivatives. Note that values are solvent-dependent (solvatochromism).[1][2]

**Table 1: Comparative UV-Vis Absorption Maxima**

Compound	Substituent Type	(nm)	Solvent	(L <sup>3</sup> mol <sup>-2</sup> ·cm <sup>-1</sup> )	Key Characteristic
Trans-Stilbene	None (Reference)	295 - 300	Ethanol/Hexane	~28,000	Planar, strong conjugation
Cis-Stilbene	None (Isomer)	280	Hexane	~10,000	Sterically hindered, twisted
4-Nitrostilbene	EWG (-NO <sub>2</sub> )	370 - 380	Ethanol	~22,000	Strong bathochromic shift due to LUMO stabilization
Resveratrol	EDG (-OH x3)	304 - 306	Ethanol	~30,000	Slight red shift; biologically relevant
Push-Pull Derivative*	EDG (-NMe <sub>2</sub> ) + EWG (-NO <sub>2</sub> )	428 - 450	Acetonitrile	>30,000	ICT band; highly solvatochromic

\*Note: Representative data for 4-dimethylamino-4'-nitrostilbene (DANS) or similar stiff-stilbene analogs.

## Mechanistic Logic Flow

The following diagram illustrates the causal relationship between structural modification and spectral shift.

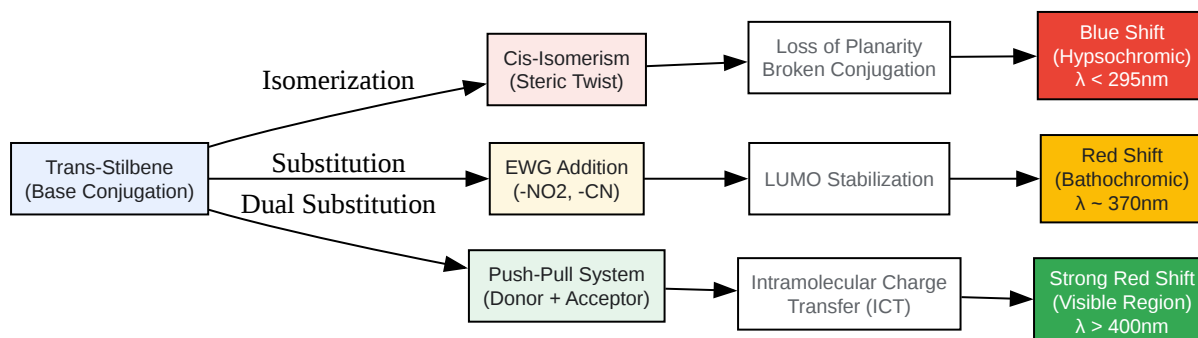

[Click to download full resolution via product page](#)

Figure 1: Decision tree illustrating the impact of geometric and electronic modifications on the spectral shift of stilbene derivatives.

## Experimental Protocol: Validated UV-Vis Acquisition

To ensure data integrity and reproducibility, the following protocol controls for common variables such as solvent cutoff, aggregation, and concentration errors.

### Materials

- Analytes: trans-Stilbene (>98% purity), Derivatives.
- Solvent: Spectroscopic grade Ethanol or Cyclohexane (UV cutoff < 210 nm).
- Equipment: Double-beam UV-Vis Spectrophotometer (e.g., Shimadzu UV-1800 or Agilent Cary 60).
- Cuvettes: Quartz (Suprasil), 10 mm path length. Do not use plastic or standard glass as they absorb in the UV region (<300 nm).

### Workflow Methodology

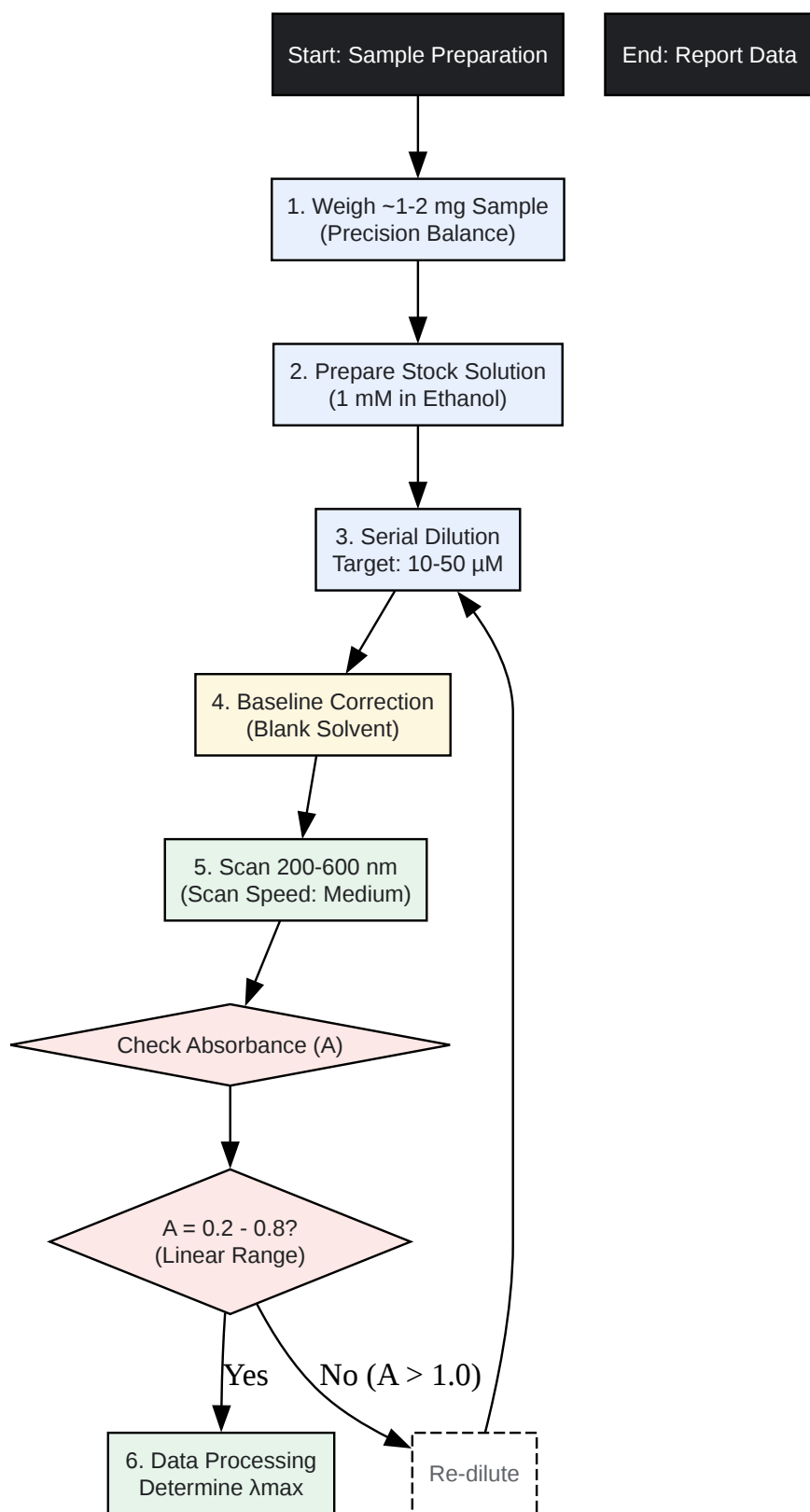

[Click to download full resolution via product page](#)

Figure 2: Step-by-step experimental workflow for accurate UV-Vis characterization.

## Critical Considerations

- **Solvent Cutoff:** Ensure the solvent does not absorb in the region of interest. Ethanol (cutoff 205 nm) is ideal for stilbenes. Acetone (cutoff 330 nm) is unsuitable as it masks the primary stilbene peak.
- **Aggregation Check:** Stilbene derivatives, especially hydrophobic ones like 4-nitrostilbene, may form aggregates (H- or J-aggregates) at high concentrations. Validate the Beer-Lambert Law by measuring three concentrations; the absorbance should remain constant, and Absorbance should scale linearly.
- **Photochemical Instability:** Trans-stilbene undergoes photoisomerization to cis-stilbene upon UV exposure. Minimize ambient light exposure during preparation and measure immediately after placing the cuvette in the holder.

## Solvatochromism: The Solvent Effect[6]

While unsubstituted trans-stilbene is relatively insensitive to solvent polarity (non-polar ground and excited states), push-pull derivatives exhibit significant positive solvatochromism.

- **Mechanism:** The excited state of a push-pull stilbene is highly polar (Intramolecular Charge Transfer state).[2] Polar solvents (e.g., DMSO, Acetonitrile) stabilize this excited state more than the ground state, lowering the energy gap and causing a red shift.
- **Application:** This property allows push-pull stilbenes to function as polarity probes in biological membranes.

## References

- BenchChem. (2025).[4][5] A Researcher's Guide to Spectroscopic Differentiation of Cis- and Trans-Stilbene Isomers. [Link](#)
- University of Southern California. (2017). Two-photon absorption spectroscopy of trans-stilbene, cis-stilbene, and phenanthrene: Theory and experiment. [Link](#)
- National Institutes of Health (PMC). (2021). Push-Pull Stiff-Stilbene: Proton-Gated Visible-Light Photoswitching. [Link](#)

- Royal Society of Chemistry. A comparative analysis of the UV/Vis absorption spectra of nitrobenzaldehydes (and related stilbene contexts). [Link](#)
- MDPI. (2011). Spectroscopic Study of Solvent Effects on the Electronic Absorption Spectra. [Link](#)

### Need Custom Synthesis?

BenchChem offers custom synthesis for rare earth carbides and specific isotopic labeling.

Email: [info@benchchem.com](mailto:info@benchchem.com) or [Request Quote Online](#).

## Sources

- 1. [mdpi.com](https://www.mdpi.com) [[mdpi.com](https://www.mdpi.com)]
- 2. [pjps.pk](https://www.pjps.pk) [[pjps.pk](https://www.pjps.pk)]
- 3. Push-Pull Stiff-Stilbene: Proton-Gated Visible-Light Photoswitching and Acid-Catalyzed Isomerization - PMC [[pmc.ncbi.nlm.nih.gov](https://pubmed.ncbi.nlm.nih.gov)]
- 4. [pdf.benchchem.com](https://pdf.benchchem.com) [[pdf.benchchem.com](https://pdf.benchchem.com)]
- 5. [pdf.benchchem.com](https://pdf.benchchem.com) [[pdf.benchchem.com](https://pdf.benchchem.com)]
- To cite this document: BenchChem. [UV-Vis Absorption Characteristics of Stilbene and Derivatives: A Comparative Technical Guide]. BenchChem, [2026]. [Online PDF]. Available at: [<https://www.benchchem.com/product/b1623112/docs#uv-vis-absorption-characteristics-of-stilbene-and-derivatives-a-comparative-technical-guide>]

---

### Disclaimer & Data Validity:

The information provided in this document is for Research Use Only (RUO) and is strictly not intended for diagnostic or therapeutic procedures. While BenchChem strives to provide accurate protocols, we make no warranties, express or implied, regarding the fitness of this product for every specific experimental setup.

**Technical Support:** The protocols provided are for reference purposes. Unsure if this reagent suits your experiment?

**Need Industrial/Bulk Grade?** [Request Custom Synthesis Quote](#)

## BenchChem

Our mission is to be the trusted global source of essential and advanced chemicals, empowering scientists and researchers to drive progress in science and industry.

### Contact

Address: 3281 E Guasti Rd  
Ontario, CA 91761, United States  
Phone: (601) 213-4426  
Email: [info@benchchem.com](mailto:info@benchchem.com)

[Contact our Ph.D. Support Team for a compatibility check](#)