

Introduction: Characterizing a Sterically Hindered Intermediate

Author: BenchChem Technical Support Team. **Date:** May 2026

Compound of Interest

Compound Name: *Boc-2,4,6-trimethylaniline*

CAS No.: 56700-69-7

Cat. No.: B1623133

[Get Quote](#)

In the landscape of pharmaceutical and materials science, the synthesis of complex molecules often relies on the use of protecting groups to selectively mask reactive sites. The tert-butoxycarbonyl (Boc) group is one of the most ubiquitous amine-protecting groups due to its stability under various conditions and its facile removal under mild acidic treatment. **Boc-2,4,6-trimethylaniline** is a key intermediate that combines the Boc protecting group with a sterically demanding aromatic amine, 2,4,6-trimethylaniline (mesidine). The three methyl groups positioned ortho and para to the amine functionality impart significant steric bulk, influencing the molecule's conformation, reactivity, and spectroscopic properties.

Infrared (IR) spectroscopy is a rapid, non-destructive, and powerful analytical technique for the structural elucidation and quality control of such intermediates. By probing the vibrational modes of a molecule's functional groups, IR spectroscopy provides a unique "fingerprint," confirming the successful installation of the Boc group and verifying the integrity of the overall structure. This guide provides an in-depth analysis of the infrared spectrum of **Boc-2,4,6-trimethylaniline**, offering field-proven insights into sample preparation, spectral interpretation, and the subtle yet significant effects of steric hindrance on key vibrational frequencies.

Molecular Structure and Expected Vibrational Modes

Understanding the infrared spectrum begins with a clear picture of the molecule's structure and its constituent functional groups, each with characteristic vibrational frequencies.

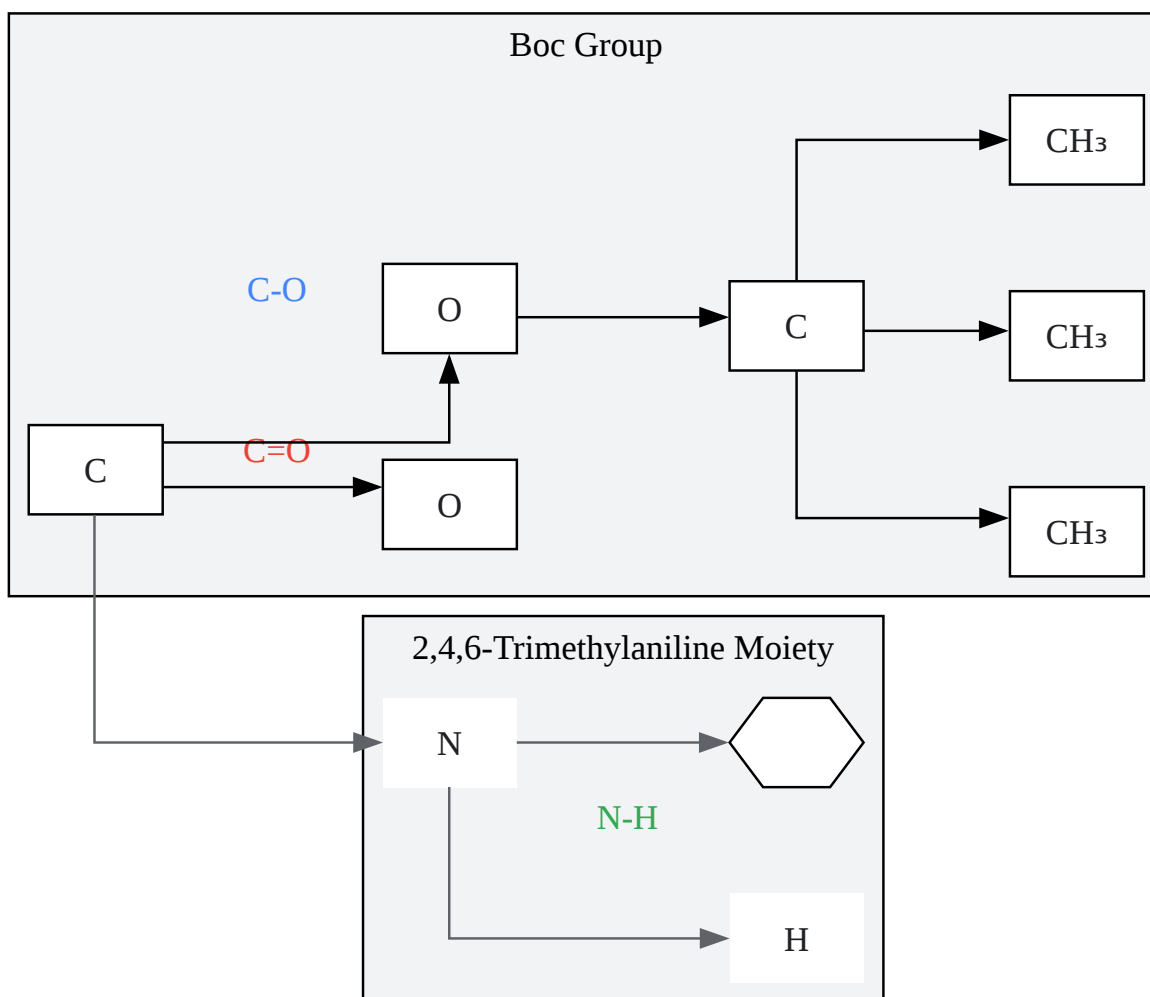

[Click to download full resolution via product page](#)

Caption: Standard experimental workflow for FTIR analysis using the KBr pellet method.

Step-by-Step KBr Pellet Preparation

- **Drying:** Gently heat spectroscopic grade KBr powder in an oven at ~110°C for several hours and store it in a desiccator. This step is critical to remove adsorbed water, which shows broad absorption bands in the IR spectrum and can obscure N-H signals. [1][2] **Grinding:** In an agate mortar and pestle, thoroughly grind approximately 1-2 mg of the **Boc-2,4,6-trimethylaniline** sample with 150-200 mg of the dried KBr. [3] The goal is to reduce the sample's particle size to less than the wavelength of the IR radiation (~2 microns) to minimize light scattering. [2] **Pellet Pressing:** Transfer the finely ground powder to a pellet die. Place the die into a hydraulic press and apply pressure (typically 7-10 tons) for several minutes to form a transparent or translucent pellet. [3] **Mounting:** Carefully remove the KBr pellet from the die and place it in the sample holder of the FTIR spectrometer.
- **Data Acquisition:** First, run a background spectrum of the empty sample compartment. Then, run the spectrum of the sample pellet. The instrument software will automatically ratio these to produce the final absorbance or transmittance spectrum.

Detailed Spectral Interpretation

The infrared spectrum of **Boc-2,4,6-trimethylaniline** provides a wealth of structural information. The analysis is best approached by examining distinct regions of the spectrum.

Wavenumber (cm ⁻¹)	Vibrational Mode	Expected Intensity	Commentary
~3400	N-H Stretch	Medium, Sharp	A single, relatively sharp peak is expected for the secondary N-H. Due to steric hindrance from ortho-methyls, intermolecular H-bonding is weak, shifting this peak to a higher frequency than in unhindered secondary amides. [4] [5]
3100-3000	Aromatic C-H Stretch	Weak to Medium	Characteristic of C-H bonds on the benzene ring.
2980-2850	Aliphatic C-H Stretch	Strong	Asymmetric and symmetric stretching of C-H bonds in the tert-butyl and aryl-methyl groups. This will be a prominent feature. [6]
~1725-1710	C=O Stretch (Amide I)	Very Strong	This is the most intense and diagnostic peak for the Boc group. Its position is typical for carbamates. The electron-donating nature of the aniline may slightly lower this frequency compared

to alkyl carbamates.

[7][8]

~1600, ~1480	Aromatic C=C Stretch	Medium	Skeletal vibrations of the aromatic ring.
~1520	N-H Bend (Amide II)	Medium to Strong	A combination of N-H in-plane bending and C-N stretching. This band is characteristic of secondary amides/carbamates. [5]
1390 & 1365	tert-Butyl Bend	Medium to Strong	A characteristic doublet arising from the symmetric and asymmetric bending of the C-H bonds in the tert-butyl group.
~1250 & ~1150	C-O Stretch	Strong	Asymmetric C-O-C and N-C-O stretching vibrations of the carbamate group. These are typically strong and broad bands. [7]
Below 900	Aromatic C-H Out-of-Plane Bend	Strong	The substitution pattern on the aromatic ring (1,2,3,5-tetrasubstituted) will give rise to strong bands in this region.

Causality Behind Key Peak Positions

- The N-H Stretch: In a typical solid-state secondary amide, extensive hydrogen bonding (N-H...O=C) broadens the N-H stretch and shifts it to a lower wavenumber (e.g., 3300 cm⁻¹). For **Boc-2,4,6-trimethylaniline**, the bulky methyl groups ortho to the nitrogen physically block adjacent molecules from approaching closely. This steric inhibition of hydrogen bonding results in an N-H vibration that is more "gas-phase" or "dilute solution" in character: sharper and at a higher frequency (~3400 cm⁻¹). [9][10]
- The Carbonyl (C=O) Stretch: The position of the carbamate carbonyl stretch is sensitive to its electronic environment. While conjugation with the aromatic ring's pi-system might be expected to lower the frequency, the steric bulk of the ortho-methyls may force the carbamate group out of the plane of the ring, disrupting this conjugation. Therefore, the C=O frequency is expected to be close to that of a non-conjugated aryl carbamate, typically in the 1710-1725 cm⁻¹ range. [11] Studies on carbamates have shown that the carbonyl absorption shifts to higher frequencies by approximately 35 cm⁻¹ when moving from a hydrogen-bonded solid phase to a non-hydrogen-bonded liquid phase. [7][11] The inhibited hydrogen bonding in solid **Boc-2,4,6-trimethylaniline** likely places its C=O frequency at the higher end of the typical solid-state range.

Conclusion

The infrared spectrum of **Boc-2,4,6-trimethylaniline** is a definitive tool for its structural verification. The key diagnostic signals are the sharp, high-frequency N-H stretch around 3400 cm⁻¹, indicative of sterically hindered hydrogen bonding, and the very strong carbamate C=O (Amide I) absorption between 1710-1725 cm⁻¹. These features, combined with the strong aliphatic C-H stretches, the N-H bend (Amide II), and the characteristic C-O stretches in the fingerprint region, provide an unambiguous confirmation of the molecule's identity. This guide demonstrates that a thorough understanding of not only functional group frequencies but also the influence of molecular architecture, such as steric hindrance, is paramount for accurate and insightful spectral interpretation in modern chemical research and development.

References

- Sampling Technique for Organic Solids in IR Spectroscopy. (2001). Journal of Chemical Education, 78(3), 257. Available at: [\[Link\]](#)

- Chen, J. T., & Benson, W. R. (1966). Characteristic Infrared Absorption Spectra and Frequencies of Carbamate Pesticides. *Journal of AOAC INTERNATIONAL*, 49(1), 412-452. Available at: [\[Link\]](#)
- Drawell. (2024). Sample Preparation for FTIR Analysis. Drawell Scientific Instrument Co., Ltd. Available at: [\[Link\]](#)
- University of Colorado Boulder. Sample preparation for FT-IR. Department of Chemistry & Biochemistry. Available at: [\[Link\]](#)
- Chen, J. T., & Benson, W. R. (2020). Characteristic Infrared Absorption Spectra and Frequencies of Carbamate Pesticides. *Journal of AOAC INTERNATIONAL*. Available at: [\[Link\]](#)
- Bossa, J. B., et al. (2014). Infrared spectra of a) carbamic acid dimer $(\text{NH}_2\text{COOH})_2$, b) ammonium carbamate $[\text{NH}_4^+][\text{NH}_2\text{COO}^-]$, and c) species D. ResearchGate. Available at: [\[Link\]](#)
- Krueger, P. J., & Thompson, H. W. (1957). Vibrational band intensities in substituted anilines. *Proceedings of the Royal Society of London. Series A. Mathematical and Physical Sciences*, 243(1233), 143-153. Available at: [\[Link\]](#)
- Domingo, C., et al. (2022). Detection of Organophosphorus, Pyrethroid, and Carbamate Pesticides in Tomato Peels: A Spectroscopic Study. PMC. Available at: [\[Link\]](#)
- Wang, Y., et al. (2023). Spectroscopic Identification of Carbamate Formation and Synergistic Binding in Amide-CO₂⁻ Complexes. ACS Publications. Available at: [\[Link\]](#)
- Edinburgh Instruments. (2023). Common Sampling Techniques of FTIR Spectroscopy. Edinburgh Instruments. Available at: [\[Link\]](#)
- WikiEducator. (n.d.). Chapter-20: Infrared spectroscopy (Identifying Compounds or ligands). WikiEducator. Available at: [\[Link\]](#)
- GSC Online Press. (2021). Synthesis of 3-(substitutedthiocarbamide)-aniline derivatives from di-tert-butyl dicarbonate (BoC) protected 3-chloroaniline. GSC Biological and Pharmaceutical Sciences. Available at: [\[Link\]](#)

- ResearchGate. (n.d.). Steric effects in the infra-red spectrum of aromatic nitro compounds. ResearchGate. Available at: [\[Link\]](#)
- Premkumar, S., et al. (2014). DFT and Experimental Studies of the Structure and Vibrational Spectra of 2-(tert-butoxycarbonyl(Boc)amino)-5-bromopyridine. AIP Conference Proceedings. Available at: [\[Link\]](#)
- Premkumar, S., et al. (2014). DFT calculation and vibrational spectroscopic studies of 2-(tert-butoxycarbonyl (Boc) -amino)-5-bromopyridine. Spectrochimica Acta Part A: Molecular and Biomolecular Spectroscopy. Available at: [\[Link\]](#)
- Chemistry LibreTexts. (2024). 24.10: Spectroscopy of Amines. Chemistry LibreTexts. Available at: [\[Link\]](#)
- ResearchGate. (n.d.). Comparison of (a) experimental IR spectrum of aniline with theoretical... ResearchGate. Available at: [\[Link\]](#)
- University of Calgary. (n.d.). IR: amines. University of Calgary. Available at: [\[Link\]](#)
- Premkumar, S., et al. (2014). DFT calculation and vibrational spectroscopic studies of 2-(tert-butoxycarbonyl (Boc) -amino)-5-bromopyridine. ResearchGate. Available at: [\[Link\]](#)
- Ishimoto, T., et al. (2002). A New Electronic State of Aniline Observed in the Transient IR Absorption Spectrum from S1 in a Supersonic Jet. The Journal of Physical Chemistry A. Available at: [\[Link\]](#)
- Michigan State University. (n.d.). Infrared Spectrometry. Department of Chemistry. Available at: [\[Link\]](#)
- University of Illinois Springfield. (n.d.). 13.10 INTERPRETATION OF IR SPECTRA. University of Illinois Springfield. Available at: [\[Link\]](#)
- SciSpace. (n.d.). N-H Stretching Frequencies of Amines and Amides. SciSpace. Available at: [\[Link\]](#)
- Der Pharma Chemica. (2015). Solvent-free, instant, ambient, n-boc protection of amines -A green, recyclable heterogenous acid catalysis. Der Pharma Chemica, 7(10), 332-337.

Available at: [\[Link\]](#)

- S.P.C.M.C. (n.d.). INFRARED SPECTROSCOPY. S.P.C.M.C. Available at: [\[Link\]](#)
- Chen, C., et al. (2020). A New Measurement of Amine Steric Hindrance – N Exposure. OSTI.GOV. Available at: [\[Link\]](#)
- ResearchGate. (2014). DFT calculation and vibrational spectroscopic studies of 2-(tert-butoxycarbonyl (Boc) -amino)-5-bromopyridine. ResearchGate. Available at: [\[Link\]](#)
- Amrita Vishwa Vidyapeetham. (2014). DFT calculation and vibrational spectroscopic studies of 2-(tert-butoxycarbonyl (Boc) -amino)-5-bromopyridine. Amrita Vishwa Vidyapeetham. Available at: [\[Link\]](#)
- ResearchGate. (n.d.). FT-IR spectra of N-BOC-150, N-BOC-180, and N-BOC-210 samples (a) and... ResearchGate. Available at: [\[Link\]](#)
- YouTube. (2023). Aromatic amines - resonance effect and steric effects on Basicity. YouTube. Available at: [\[Link\]](#)
- Wikipedia. (n.d.). 2,4,6-Trimethylaniline. Wikipedia. Available at: [\[Link\]](#)
- ResearchGate. (n.d.). Deprotection of Boc from 3-(thiosubstitutedcarbamido) aniline compound... ResearchGate. Available at: [\[Link\]](#)
- Taylor & Francis Online. (n.d.). Steric hindrance – Knowledge and References. Taylor & Francis Online. Available at: [\[Link\]](#)
- SlidePlayer. (n.d.). Infrared (IR) Spectroscopy. SlidePlayer. Available at: [\[Link\]](#)
- SciSpace. (n.d.). Efficient deprotection of Boc group in amines and sulfamides using Dawson heteropolyacid catalyst. SciSpace. Available at: [\[Link\]](#)
- Mahavir Synthesis. (n.d.). 2,4,6-trimethyl Aniline. Mahavir Synthesis. Available at: [\[Link\]](#)
- Kenyatta University. (n.d.). Browsing School of Pure and Applied Sciences by Subject "2,4,6-Trimethylaniline". Kenyatta University Institutional Repository. Available at: [\[Link\]](#)

- SpectraBase. (n.d.). 2,4,6-Trimethylaniline. SpectraBase. Available at: [\[Link\]](#)
- Wired Chemist. (n.d.). 2,4,6-trimethylaniline Proton Full Spectrum. Wired Chemist. Available at: [\[Link\]](#)
- OEHHA. (2011). 2,4,6-Trimethylaniline and Its Salts. Office of Environmental Health Hazard Assessment. Available at: [\[Link\]](#)
- NIST. (n.d.). Benzenamine, 2,4,6-trimethyl-. NIST WebBook. Available at: [\[Link\]](#)

Need Custom Synthesis?

BenchChem offers custom synthesis for rare earth carbides and specific isotopic labeling.

Email: info@benchchem.com or [Request Quote Online](#).

Sources

- 1. jascoinc.com [jascoinc.com]
- 2. eng.uc.edu [eng.uc.edu]
- 3. drawellanalytical.com [drawellanalytical.com]
- 4. orgchemboulder.com [orgchemboulder.com]
- 5. Infrared Spectrometry [www2.chemistry.msu.edu]
- 6. researchgate.net [researchgate.net]
- 7. academic.oup.com [academic.oup.com]
- 8. Detection of Organophosphorus, Pyrethroid, and Carbamate Pesticides in Tomato Peels: A Spectroscopic Study - PMC [pmc.ncbi.nlm.nih.gov]
- 9. chem.libretexts.org [chem.libretexts.org]
- 10. spsmc.ac.in [spsmc.ac.in]
- 11. academic.oup.com [academic.oup.com]
- To cite this document: BenchChem. [Introduction: Characterizing a Sterically Hindered Intermediate]. BenchChem, [2026]. [Online PDF]. Available at: [\[https://www.benchchem.com/product/b1623133/docs#introduction-characterizing-a-sterically-hindered-intermediate\]](https://www.benchchem.com/product/b1623133/docs#introduction-characterizing-a-sterically-hindered-intermediate)

Disclaimer & Data Validity:

The information provided in this document is for Research Use Only (RUO) and is strictly not intended for diagnostic or therapeutic procedures. While BenchChem strives to provide accurate protocols, we make no warranties, express or implied, regarding the fitness of this product for every specific experimental setup.

Technical Support: The protocols provided are for reference purposes. Unsure if this reagent suits your experiment?

Need Industrial/Bulk Grade? [Request Custom Synthesis Quote](#)

BenchChem

Our mission is to be the trusted global source of essential and advanced chemicals, empowering scientists and researchers to drive progress in science and industry.

Contact

Address: 3281 E Guasti Rd
Ontario, CA 91761, United States
Phone: (601) 213-4426
Email: info@benchchem.com

[Contact our Ph.D. Support Team for a compatibility check](#)