

Ensuring Metadata Accuracy in Omics Research: A Comparative Guide to COPO

Author: BenchChem Technical Support Team. **Date:** April 2026

Compound of Interest

Compound Name:	CoPo 22
CAS No.:	606101-83-1
Cat. No.:	B1623416

[Get Quote](#)

In the realm of genomics, transcriptomics, and other omics disciplines, the accuracy and richness of metadata are paramount for the reusability and interpretation of experimental data. The Collaborative Open Plant Omics (COPO) platform is a data brokering system designed to streamline the submission of omics data and associated metadata to public repositories, with a strong emphasis on ensuring high-quality, accurate metadata. This guide provides a comprehensive overview of how COPO achieves this, compares its methodologies with other leading metadata management tools, and details the validation protocols it employs.

How COPO Upholds Metadata Accuracy

COPO employs a multi-faceted approach to ensure the integrity and accuracy of metadata throughout the data submission lifecycle. This approach is built on the pillars of standardization, validation, and user-friendly workflows.

A key strategy is the adoption of and adherence to community-sanctioned standards.^[1] COPO leverages well-established schemas such as Darwin Core (DwC) for biodiversity data and the Minimum Information about any (x) Sequence (MIxS) standard for genomic and metagenomic data.^[1] By mapping user-submitted information to these standards, COPO ensures that

metadata is structured, consistent, and interoperable across different datasets and platforms.[2] This standardization is crucial for the discoverability and reuse of data.

To further enforce these standards and minimize human error, COPO has implemented a robust validation framework. This includes both automated checks and, for certain projects, a manual curation step. The platform provides user-friendly web interfaces and spreadsheet-based templates to guide researchers in providing comprehensive metadata.[3] These interfaces incorporate validation rules that check for the presence of mandatory fields, correct data formatting, and logical consistency. For instance, COPO can flag an error if a user attempts to associate the same specimen ID with two different taxon IDs.

A significant feature of COPO's validation process is its integration with external, authoritative validation services. Notably, COPO is one of the first web-based platforms to utilize the EMBL-EBI European Nucleotide Archive (ENA) command-line validation client.[4] This allows for a rigorous, resource-intensive validation of metadata against the specific requirements of this major public repository. COPO's infrastructure is designed to handle these intensive validation tasks, offloading the burden from the individual researcher.

For large-scale, collaborative projects such as the Darwin Tree of Life, COPO facilitates a harmonized metadata collection process. It provides a unified entry point for data submission, ensuring that metadata from various contributors is captured in a consistent manner. This is often complemented by a manual review process where designated "Sample Supervisors" inspect and approve metadata before its final submission to public archives.

Finally, COPO promotes the use of controlled vocabularies and ontologies.[5] By encouraging researchers to use specific and agreed-upon terms for describing their data, COPO enhances the consistency and semantic clarity of the metadata, making it more readily searchable and analyzable.

Comparative Analysis of Metadata Accuracy

Features

While several tools exist to aid researchers in managing experimental metadata, their approaches to ensuring accuracy vary. Here, we compare COPO with two other widely used platforms: ISA-Tools and FAIRDOM-SEEK.

Feature	COPO (Collaborative Open Plant Omics)	ISA-Tools	FAIRDOM-SEEK
Primary Focus	Data brokering and metadata submission to public archives.	Creating and managing ISA-formatted metadata files locally.	A data and model management platform for systems biology projects.
Validation Approach	Multi-level validation including internal checks, integration with external validators (e.g., ENA), and optional manual curation.	Primarily local validation against the ISA syntax and configuration files.	Supports validation of extended metadata based on defined types and allows for required fields.
Community Standards	Strong emphasis on mapping to community standards like Darwin Core and MIxS.	Based on the ISA (Investigation, Study, Assay) metadata framework.	Supports the ISA model and can be extended to support other standards like MIAPPE through "Extended Metadata". [6]
User Interface	Web-based wizards and spreadsheet uploads designed to guide users through the submission process.	Desktop application (ISAcreeator) and command-line tools for metadata creation.	Web-based interface for managing and sharing research assets.
Automation	Automates the generation of repository-specific submission files (e.g., ENA XMLs) and the data transfer process.	Provides tools to convert ISA-formatted metadata into other formats for submission.	Focuses on linking and organizing data, models, and publications within a project.

Strengths in Accuracy	Rigorous, multi-stage validation process; direct integration with public repository validation tools; enforcement of community standards.	Enforces a structured metadata framework; local validation provides immediate feedback to the user.	Customizable metadata validation; supports the use of controlled vocabularies and ontologies.
-----------------------	---	---	---

Experimental Protocols: COPO's Metadata Validation Workflow

The following sections detail the step-by-step processes COPO employs to validate and ensure the accuracy of submitted metadata. These workflows represent the "experimental protocols" for achieving high-quality metadata.

Metadata Submission and Initial Validation

The process begins with the user submitting their sample metadata, typically through a pre-configured spreadsheet template or a web-based wizard. This initial step includes built-in checks to catch common errors at the point of entry.

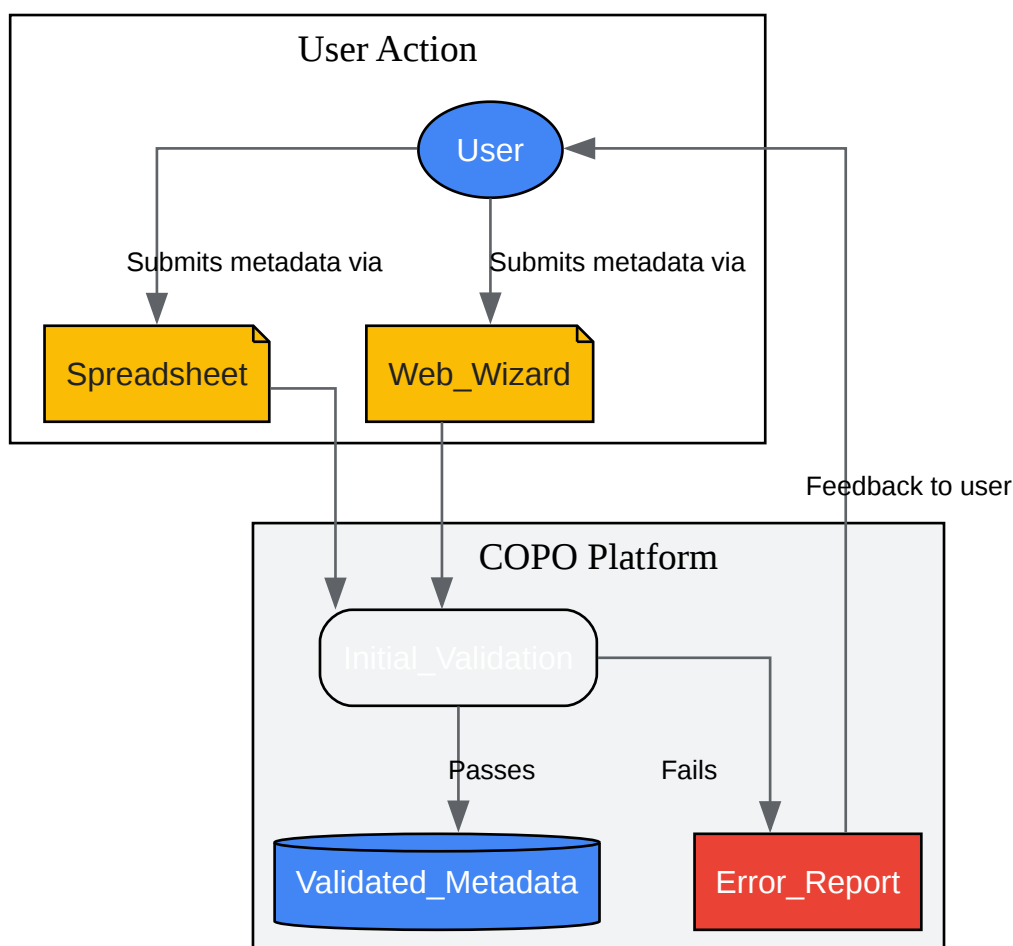

[Click to download full resolution via product page](#)

Caption: Initial metadata submission and validation workflow in COPO.

This initial validation step checks for:

- **Completeness:** Ensures all mandatory fields, as defined by the relevant community standard or project-specific requirements, are filled.
- **Formatting:** Verifies that data is entered in the correct format (e.g., dates, numerical values).
- **Consistency:** Performs basic logical checks, such as ensuring unique identifiers are indeed unique within the submission.

Automated Standardization and Enrichment

Once the initial validation is passed, COPO proceeds to standardize and enrich the metadata. This involves mapping the user-provided information to the appropriate terms from community standards like Darwin Core and MIxS.

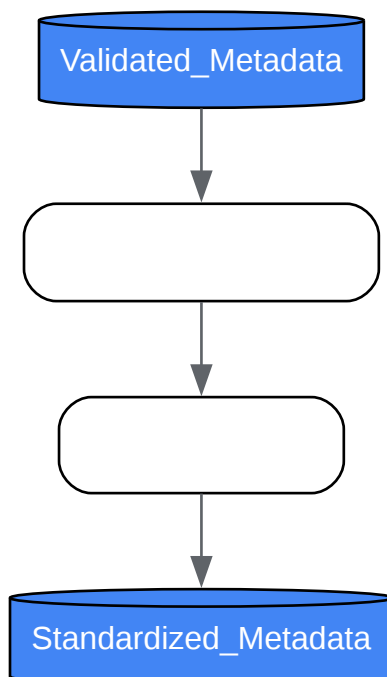

[Click to download full resolution via product page](#)

Caption: Automated metadata standardization and enrichment process.

During this stage, COPO may also perform lookups against ontological services to validate or suggest standardized terms, further enhancing the interoperability of the metadata.

External Validation and Manual Curation

For submissions to repositories like the ENA, COPO initiates an external validation step. This is a critical part of the process where the metadata is checked against the specific and often complex rules of the target repository. For certain collaborative projects, a manual curation step is also included.

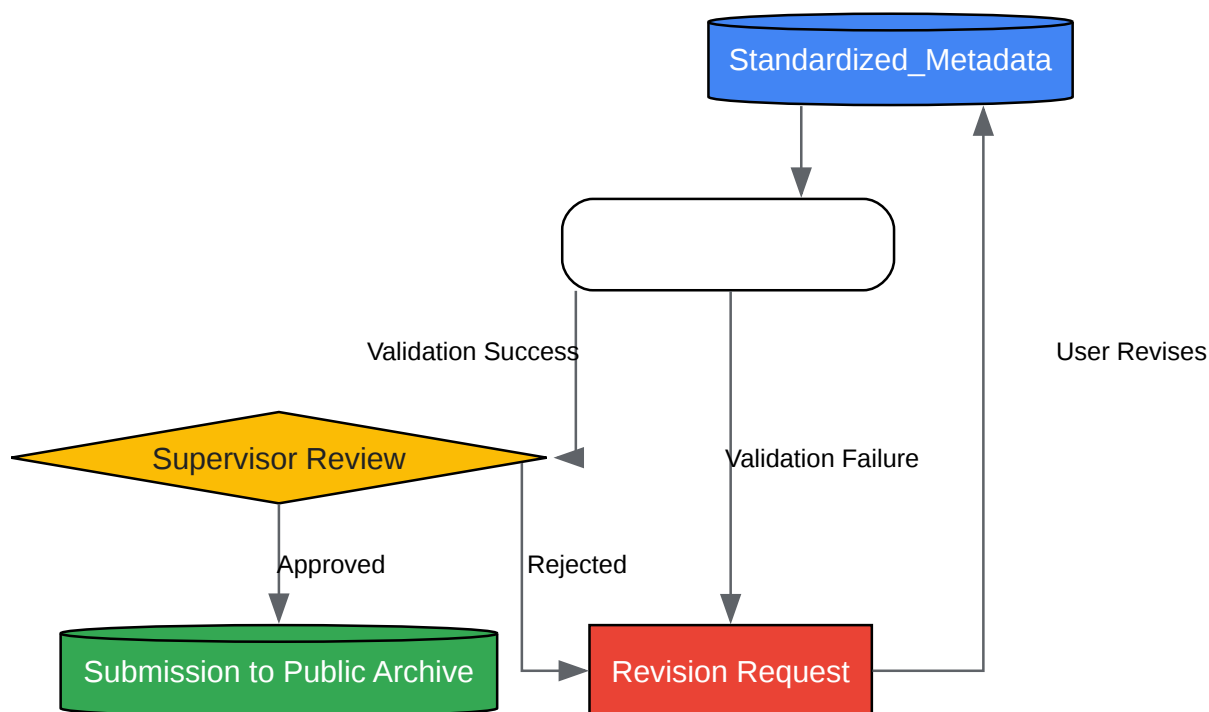

[Click to download full resolution via product page](#)

Caption: External validation and manual curation workflow in COPO.

If the external validation fails or a curator rejects the submission, feedback is provided to the user for revision. This iterative process ensures that the metadata meets the high standards of public repositories before deposition.

Brokering and Finalization

Upon successful validation and curation, COPO handles the final steps of data and metadata submission. This includes generating the necessary repository-specific file formats (e.g., XML for ENA) and managing the transfer of data files to the repository's servers.

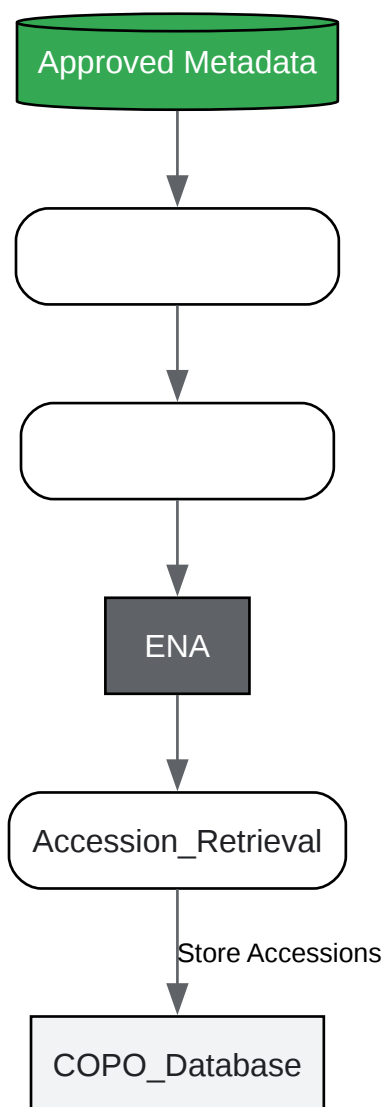

[Click to download full resolution via product page](#)

Caption: Data and metadata brokering and finalization process.

COPO then retrieves the accession numbers from the public archive and stores them, providing the user with a complete record of their submission.

In conclusion, COPO's systematic approach to metadata validation, which combines adherence to community standards, a multi-layered validation process, and user-centric workflows, significantly enhances the accuracy and quality of metadata in public omics repositories. This commitment to data quality is essential for fostering a research ecosystem where data is truly Findable, Accessible, Interoperable, and Reusable (FAIR).

Need Custom Synthesis?

BenchChem offers custom synthesis for rare earth carbides and specific isotopic labeling.

Email: info@benchchem.com or [Request Quote Online](#).

References

- [1. copo-project.org \[copo-project.org\]](https://copo-project.org)
- [2. events.hifis.net \[events.hifis.net\]](https://events.hifis.net)
- [3. wellcomeopenresearch-files.f1000.com \[wellcomeopenresearch-files.f1000.com\]](https://wellcomeopenresearch-files.f1000.com)
- [4. ora.ox.ac.uk \[ora.ox.ac.uk\]](https://ora.ox.ac.uk)
- [5. COPO: a metadata platform for brokering FAIR data... | F1000Research \[f1000research.com\]](#)
- [6. project: MIAPPE, Plant Data Integration and Findability | FAIRDOME \[fair-dom.org\]](#)
- [To cite this document: BenchChem. \[Ensuring Metadata Accuracy in Omics Research: A Comparative Guide to COPO\]. BenchChem, \[2026\]. \[Online PDF\]. Available at: \[https://www.benchchem.com/product/b1623416/docs#ensuring-metadata-accuracy-in-omics-research-a-comparative-guide-to-copo\]](#)

Disclaimer & Data Validity:

The information provided in this document is for Research Use Only (RUO) and is strictly not intended for diagnostic or therapeutic procedures. While BenchChem strives to provide accurate protocols, we make no warranties, express or implied, regarding the fitness of this product for every specific experimental setup.

Technical Support: The protocols provided are for reference purposes. Unsure if this reagent suits your experiment?

Need Industrial/Bulk Grade? [Request Custom Synthesis Quote](#)

BenchChem

Our mission is to be the trusted global source of essential and advanced chemicals, empowering scientists and researchers to drive progress in science and industry.

Contact

Address: 3281 E Guasti Rd

Ontario, CA 91761, United States

Phone: (601) 213-4426

Email: info@benchchem.com

[Contact our Ph.D. Support Team for a compatibility check](#)