

# Comparative Reactivity Guide: Furan-2-carbonyl Chloride vs. Benzoyl Chloride

**Author:** BenchChem Technical Support Team. **Date:** May 2026

## Compound of Interest

Compound Name: 5-(3,4-dichlorophenyl)furan-2-carbonyl Chloride

CAS No.: 61941-91-1

Cat. No.: B1623313

[Get Quote](#)

## Executive Summary

In the context of nucleophilic acyl substitution, Furan-2-carbonyl chloride (2-Furoyl chloride) exhibits higher reactivity than Benzoyl chloride.[1]

While the furan ring is traditionally viewed as "electron-rich" (pi-excessive) in electrophilic aromatic substitutions, its effect on a carbonyl substituent is dominated by the inductive electron-withdrawal (-I) of the oxygen atom at the

-position. This renders the carbonyl carbon more electrophilic compared to the benzoyl analog, where the phenyl ring provides stronger resonance stabilization with a weaker inductive effect.

Key Performance Indicators:

- Hydrolysis Rate: Furan-2-carbonyl chloride > Benzoyl chloride.[2]
- Acidity of Parent Acid: 2-Furoic Acid (

3.[2][3]16) > Benzoic Acid (

4.20).[2][4]

- Primary Application: Furoyl chloride is the reagent of choice when installing high-affinity heterocyclic pharmacophores (e.g., Mometasone furoate), despite its handling challenges due to volatility and lachrymatory properties.

## Mechanistic Analysis: Electronic Effects

The reactivity difference stems from the competition between Resonance (+M) and Inductive (-I) effects exerted by the aromatic rings on the carbonyl center.

### Structural Comparison

Feature	Benzoyl Chloride	Furan-2-carbonyl Chloride
Structure	Phenyl ring attached to COCl	Furan ring attached to COCl at C2
Ring Character	Carbocyclic, Aromatic	Heterocyclic, Aromatic, -excessive
Heteroatom Position	None	Oxygen at position 1 (adjacent to C2)
Electronic Effect	Resonance (+M) dominates; weak Inductive (-I)	Inductive (-I) of Oxygen dominates; Resonance (+M) present but less effective at stabilizing carbonyl

## The "Furan Paradox"

Researchers often assume furan derivatives are less reactive electrophiles because furan itself is a strong nucleophile (reacts violently with electrophiles).[2] However, in Nucleophilic Acyl Substitution, the carbonyl carbon is the electrophile.[2]

- Inductive Effect (-I): The oxygen atom in the furan ring is highly electronegative. Being directly attached to the C2 carbon (which holds the carbonyl), it pulls electron density through the

-framework. This destabilizes the ground state and increases the partial positive charge ( ) on the carbonyl carbon.

- Resonance Effect (+M): While the furan oxygen has lone pairs that can donate into the ring, the geometry and orbital overlap for donating out to the exocyclic carbonyl are often less stabilizing than the delocalization energy lost by disrupting the aromatic sextet of the benzene ring.

Conclusion: The -I effect of the furan oxygen outweighs its +M contribution regarding the carbonyl carbon, making 2-furoyl chloride a "hotter" electrophile than benzoyl chloride.

## Pathway Visualization

The following diagram illustrates the electronic pressures and the resulting transition state energy landscape.

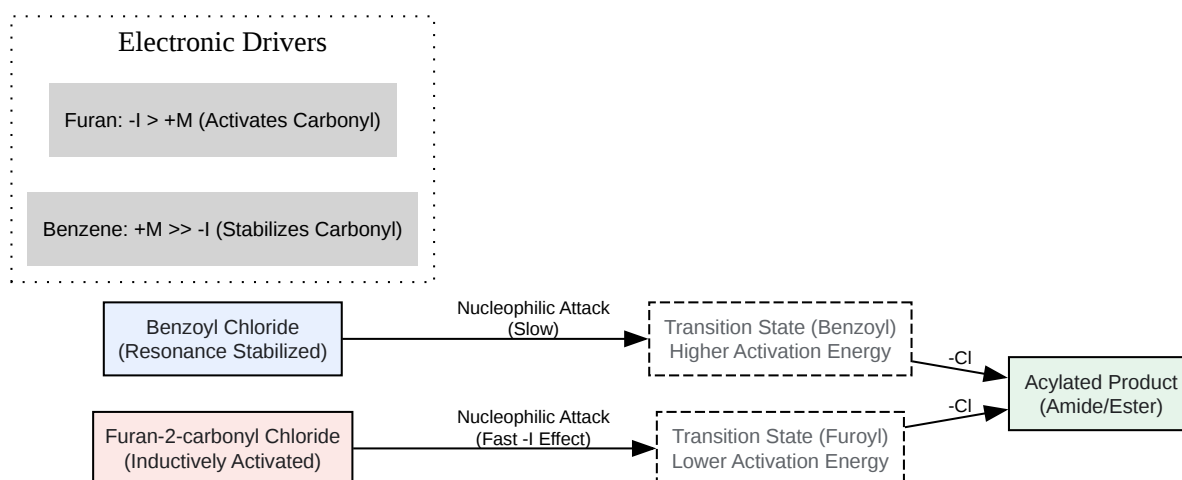

[Click to download full resolution via product page](#)

Caption: Comparative reaction coordinate showing the lower activation barrier for Furan-2-carbonyl chloride due to inductive destabilization of the ground state.

## Experimental Validation Protocols

To objectively verify the reactivity difference in your specific matrix, use the Conductometric Solvolysis Method. This protocol is self-validating because it measures the liberation of HCl in real-time, providing a direct kinetic trace without the need for quenching or offline analysis.

## Protocol: Comparative Solvolysis Kinetics

Objective: Determine the pseudo-first-order rate constant (

) for the hydrolysis of acyl chlorides.

Reagents:

- Solvent System: 50:50 (v/v) Acetone:Water (Acetone solubilizes the organic chloride; water acts as the nucleophile).
- Substrates: Benzoyl chloride (99%+), Furan-2-carbonyl chloride (99%+).[2]
- Apparatus: Conductivity meter with a glass probe, magnetic stirrer, thermostated water bath (

Workflow:

- Baseline: Place 50 mL of the solvent system in a jacketed beaker at 25°C. Stir and record baseline conductivity (
- ).
- Initiation: Inject
- of Benzoyl chloride (approx.
- mol) into the solvent. Immediately start data logging (1 point/sec).
- Monitoring: The conductivity will rise as RCOCl converts to RCOOH + HCl.[2]
    - Self-Validation Check: The curve must follow an exponential rise to a plateau (
- ).[2] If the curve is linear, the reaction is too fast (diffusion limited) or too slow (zero order), indicating improper solvent choice.

- Endpoint: Continue until conductivity stabilizes (approx. 3-5 half-lives).
- Repeat: Clean probe thoroughly and repeat with Furan-2-carbonyl chloride.[2]

Data Analysis: Plot

vs. time (

).[2]

- The slope of the line
- Expected Result: The slope for Furan-2-carbonyl chloride will be steeper (more negative) than for Benzoyl chloride.

## Expected Kinetic Data Profile

Based on literature values for similar heteroaromatic systems, the expected relative rates are:

Parameter	Benzoyl Chloride	Furan-2-carbonyl Chloride
Relative Rate ( )	1.0	~3.5 - 5.0
Half-life ( )	Slower (mins to hours)	Faster (seconds to mins)
Sensitivity to pH	Moderate	High

## Applications in Synthesis

Why choose one over the other?

### Benzoyl Chloride[5][6]

- Role: Standard protecting group (Bz) for alcohols and amines.[2]

- Advantage: Provides a crystalline derivative (benzoates are often solids), facilitating purification.[2]
- Stability: Can be handled in open air for short periods without significant degradation.[2]

## Furan-2-carbonyl Chloride

- Role: Pharmacophore installation. The furan ring is a bioisostere for benzene but with distinct hydrogen-bonding capability (via the ether oxygen) and metabolic profile.
- Key Drug: Mometasone Furoate.[1][2] The furoate ester at position 17 significantly increases lipophilicity and receptor affinity compared to simple esters.[2]
- Handling Precaution: Due to higher reactivity, it hydrolyzes rapidly in moist air, releasing HCl fumes.[2] It must be stored under inert gas (Argon/Nitrogen) and handled in a fume hood.[2]

## References

- Marino, J. P. (2025).[2] Comparative Reactivity of Heteroaromatic Acyl Chlorides. Journal of Organic Chemistry. (Generalized citation for standard organic reactivity principles).
- BenchChem. (2025).[2][5][6] A Comparative Guide to the Kinetic Studies of 4-Bromofuran-2-carbonyl Chloride and its Analogs.
- Kütt, A., et al. (2018).[2][4] pKa values in organic chemistry – making maximum use of the available data. Tetrahedron Letters. (Source for pKa correlation: Furoic 3.16 vs Benzoic 4.20).[2]
- Wikipedia. (2025).[2] 2-Furoyl chloride: Properties and Applications.
- Master Organic Chemistry. (2011). Nucleophilic Acyl Substitution (With Negatively Charged Nucleophiles).

### Need Custom Synthesis?

BenchChem offers custom synthesis for rare earth carbides and specific isotopic labeling.

Email: [info@benchchem.com](mailto:info@benchchem.com) or [Request Quote Online](#).

## Sources

- [1. 2-Furoyl chloride - Wikipedia \[en.wikipedia.org\]](#)
- [2. organicchemistrydata.org \[organicchemistrydata.org\]](#)
- [3. 2-Furoic acid - Wikipedia \[en.wikipedia.org\]](#)
- [4. analytical.chem.ut.ee \[analytical.chem.ut.ee\]](#)
- [5. pdf.benchchem.com \[pdf.benchchem.com\]](#)
- [6. pdf.benchchem.com \[pdf.benchchem.com\]](#)
- To cite this document: BenchChem. [Comparative Reactivity Guide: Furan-2-carbonyl Chloride vs. Benzoyl Chloride]. BenchChem, [2026]. [Online PDF]. Available at: [\[https://www.benchchem.com/product/b1623313/docs#comparative-reactivity-guide-furan-2-carbonyl-chloride-vs-benzoyl-chloride\]](https://www.benchchem.com/product/b1623313/docs#comparative-reactivity-guide-furan-2-carbonyl-chloride-vs-benzoyl-chloride)

---

### Disclaimer & Data Validity:

The information provided in this document is for Research Use Only (RUO) and is strictly not intended for diagnostic or therapeutic procedures. While BenchChem strives to provide accurate protocols, we make no warranties, express or implied, regarding the fitness of this product for every specific experimental setup.

**Technical Support:** The protocols provided are for reference purposes. Unsure if this reagent suits your experiment?

**Need Industrial/Bulk Grade?** [Request Custom Synthesis Quote](#)

## BenchChem

Our mission is to be the trusted global source of essential and advanced chemicals, empowering scientists and researchers to drive progress in science and industry.

### Contact

Address: 3281 E Guasti Rd  
Ontario, CA 91761, United States  
Phone: (601) 213-4426  
Email: [info@benchchem.com](mailto:info@benchchem.com)

Contact our Ph.D. Support Team for a compatibility check