

# Technical Guide: Solubility, Stability, and Handling of Chloromethyl Isoxazoles

**Author:** BenchChem Technical Support Team. **Date:** May 2026

## Compound of Interest

**Compound Name:** 5-(Chloromethyl)-3-(2,6-dichlorophenyl)isoxazole

**CAS No.:** 31007-74-6

**Cat. No.:** B1621106

[Get Quote](#)

## Executive Summary

Chloromethyl isoxazoles (e.g., 3-chloromethyl-5-methylisoxazole, CAS 35166-37-1) represent a critical class of heterocyclic intermediates in the synthesis of semi-synthetic penicillins (isoxazolyl penicillins) and novel agrochemicals. Their utility is defined by a dichotomy of reactivity: the isoxazole ring offers aromatic stability under neutral/acidic conditions, while the chloromethyl moiety functions as a potent electrophile, susceptible to nucleophilic attack.

This guide provides a rigorous technical analysis of the solubility and stability profiles of these compounds. It is designed to prevent common experimental failures—specifically, unintended ring cleavage under basic conditions and uncontrolled hydrolysis of the alkyl chloride.

## Physicochemical Profile

### Solubility Characteristics

Chloromethyl isoxazoles are lipophilic small molecules. While they lack ionizable groups in the physiological pH range (unlike their carboxylic acid derivatives), their polarity is modulated by

the N-O dipole.

Table 1: Solubility Profile of 3-Chloromethyl-5-methylisoxazole

Solvent System	Solubility Rating	Operational Note
Dichloromethane (DCM)	High (>100 mg/mL)	Preferred solvent for synthesis and extraction.
Acetonitrile (MeCN)	High (>100 mg/mL)	Ideal for HPLC sample preparation and nucleophilic substitution reactions.
Methanol/Ethanol	High	Caution: Solvolysis (ether formation) can occur upon prolonged storage or heating.
Water (Neutral)	Low (<1 mg/mL)	Forms biphasic mixtures; requires co-solvent (e.g., DMSO) for aqueous assays.
Water (Acidic pH < 4)	Low	Stable suspension; ring remains intact.
Water (Basic pH > 9)	Low (Transient)	Unstable: Promotes rapid hydrolysis and potential ring degradation.

## Electronic Properties[1]

- LogP (Predicted): ~1.7 – 2.0 (Lipophilic).
- Electrophilicity: The chloromethyl carbon is highly electrophilic due to the electron-withdrawing nature of the isoxazole ring (inductive effect of the N=C bond).

## Stability & Reactivity Architecture

The stability of chloromethyl isoxazoles must be understood through two distinct mechanisms: Side-Chain Reactivity (Primary) and Ring Lability (Secondary).

## Hydrolytic Stability

- Neutral/Acidic (pH 1–7): The isoxazole ring is robust. The chloromethyl group undergoes slow hydrolysis to the hydroxymethyl derivative (h at 25°C).
- Basic (pH > 9): High Risk. Base catalyzes the hydrolysis of the chloride to alcohol. Strong bases (e.g., NaOH, alkoxides) can trigger base-catalyzed ring opening (via deprotonation of the C-4 or C-5 methyl group if present, or direct attack on the N-O bond), leading to enamino-ketone byproducts.

## Thermal Stability[1][2]

- Ambient (25°C): Stable for weeks if stored dry and dark.
- Elevated (>80°C): Susceptible to thermal degradation, particularly in the presence of trace moisture (HCl generation autocatalyzes decomposition).

## Nucleophilic Susceptibility

The chloromethyl group is a "soft" alkylating agent. It reacts rapidly with:

- Thiols (R-SH): Fast reaction, often used for conjugation.
- Amines (R-NH<sub>2</sub>): Fast reaction, but can lead to complex mixtures if the amine acts as a base (causing ring opening).

## Mechanistic Visualization

The following diagram details the divergent degradation pathways. Note the critical "Red Zone" under basic conditions.

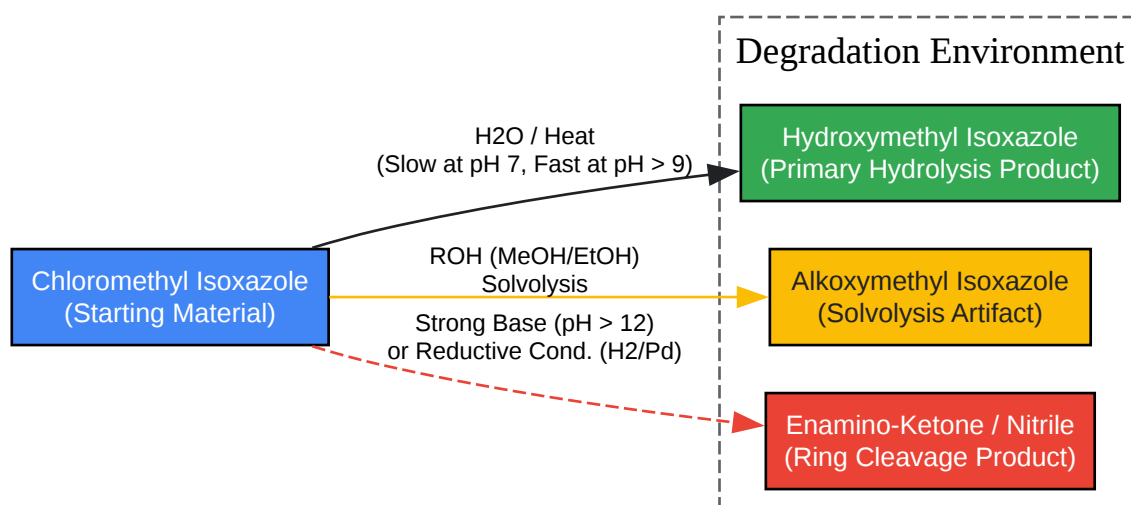

[Click to download full resolution via product page](#)

Figure 1: Degradation pathways of chloromethyl isoxazoles. Green indicates the primary hydrolysis route; Red indicates irreversible scaffold destruction.

## Analytical Methodologies

To validate stability, a specific Reverse-Phase HPLC method is required. Generic methods often fail to separate the chloro- precursor from the hydroxy- degradant due to similar polarity.

### Validated HPLC Protocol

Objective: Quantify 3-chloromethyl-5-methylisoxazole and detect hydrolysis products.

- Column: C18 (e.g., Agilent Zorbax Eclipse Plus), 4.6 x 150 mm, 5  $\mu$ m.
- Mobile Phase A: 0.1% Phosphoric Acid in Water (Suppresses silanol activity).
- Mobile Phase B: Acetonitrile (HPLC Grade).
- Gradient:
  - 0–2 min: 10% B (Isocratic hold)
  - 2–12 min: 10%  $\rightarrow$  90% B (Linear ramp)

- 12–15 min: 90% B (Wash)
- Flow Rate: 1.0 mL/min.
- Detection: UV @ 220 nm (End absorption) and 254 nm (Aromatic ring).
- Temperature: 25°C.

#### Self-Validation Check:

- Inject a standard of the chloromethyl compound.
- Inject a sample forced-degraded in 0.1M NaOH (1 hour).
- Pass Criteria: The degraded sample must show a new peak (Hydroxymethyl derivative) eluting earlier (lower retention time) than the parent peak due to increased polarity.

## Experimental Protocols

### Protocol 1: Aqueous Stability Profiling

Purpose: Determine the half-life (

) of the chloromethyl group in physiological buffer.

- Stock Preparation: Dissolve 10 mg of chloromethyl isoxazole in 1 mL Acetonitrile (10 mg/mL).
- Buffer Preparation: Prepare 0.1M Phosphate Buffer (pH 7.4) and 0.1M HCl (pH 1.0).
- Incubation:
  - Add 50  $\mu$ L Stock to 950  $\mu$ L Buffer (Final conc: 0.5 mg/mL, 5% ACN).
  - Incubate in a thermomixer at 37°C.
- Sampling:
  - Aliquot 100  $\mu$ L at T=0, 1h, 4h, 8h, 24h.

- Quench: Immediately add 100  $\mu$ L cold Acetonitrile to stop the reaction.
- Analysis: Analyze via HPLC method (Section 5.1). Plot  
vs. Time to determine

## Protocol 2: Controlled Hydrolysis (Synthesis of Hydroxymethyl Derivative)

Purpose: Generate the reference standard for stability studies without destroying the ring.

- Dissolution: Dissolve 1.0 eq of chloromethyl isoxazole in 1:1 Dioxane/Water.
- Reagent: Add 1.1 eq of Calcium Carbonate ( ). Note: Avoid strong bases like NaOH to prevent ring opening.
- Reflux: Heat to reflux (approx. 100°C) for 4–6 hours. Monitor by TLC (Hexane/EtOAc 3:1).
- Workup:
  - Cool to RT. Filter off inorganic salts.
  - Concentrate filtrate.<sup>[1]</sup> Extract with EtOAc.
  - The product (Hydroxymethyl isoxazole) will be more polar (lower ).

## Safety & Handling

- Hazard Class: Skin Corr. 1B. The chloromethyl group is a potent alkylator. Direct contact causes severe burns and potential sensitization.
- Lachrymator: Volatile derivatives may irritate eyes/mucous membranes. Handle only in a fume hood.

- Storage: Store at 2–8°C under inert atmosphere (Argon/Nitrogen). Moisture ingress leads to HCl formation, which can corrode packaging.

## References

- Synthesis and Properties of Chloromethyl Isoxazoles: Shilova, A. N., et al. "Improved Synthesis of 5-(Chloromethyl)isoxazoles from Aldoximes and 2,3-Dichloropropene." Russian Journal of Organic Chemistry, vol. 58, 2022, pp. 1554-1558.
- Isoxazole Ring Stability & Cleavage: BenchChem Technical Guides. "The Dual Nature of the Isoxazole Ring in Carboxylate Esters: A Technical Guide to Reactivity and Stability."
- Hydrolysis Kinetics of Chloromethyl Aromatics: Cleve, N. J., et al. "Kinetics of the Hydrolysis of alpha-Chlorobenzyl Esters." [2] Acta Chemica Scandinavica, 1973. [2]
- General Isoxazole Chemistry & Applications: Pinho e Melo, T. M. V. D. [3] "Recent Advances on the Synthesis and Reactivity of Isoxazoles." Current Organic Chemistry, 2005.
- HPLC Method Development for Isoxazoles: SIELC Technologies. "HPLC Method for Analysis of Hymexazol (3-Hydroxy-5-methylisoxazole)."

### Need Custom Synthesis?

BenchChem offers custom synthesis for rare earth carbides and specific isotopic labeling.

Email: [info@benchchem.com](mailto:info@benchchem.com) or [Request Quote Online](#).

## Sources

- [1. pdf.benchchem.com](https://pdf.benchchem.com) [pdf.benchchem.com]
- [2. researchgate.net](https://www.researchgate.net) [researchgate.net]
- [3. pubs.acs.org](https://pubs.acs.org) [pubs.acs.org]
- To cite this document: BenchChem. [Technical Guide: Solubility, Stability, and Handling of Chloromethyl Isoxazoles]. BenchChem, [2026]. [Online PDF]. Available at: [\[https://www.benchchem.com/product/b1621106/docs#technical-guide-solubility-stability-and-handling-of-chloromethyl-isoxazoles\]](https://www.benchchem.com/product/b1621106/docs#technical-guide-solubility-stability-and-handling-of-chloromethyl-isoxazoles)

**Disclaimer & Data Validity:**

The information provided in this document is for Research Use Only (RUO) and is strictly not intended for diagnostic or therapeutic procedures. While BenchChem strives to provide accurate protocols, we make no warranties, express or implied, regarding the fitness of this product for every specific experimental setup.

**Technical Support:** The protocols provided are for reference purposes. Unsure if this reagent suits your experiment?

**Need Industrial/Bulk Grade?** [Request Custom Synthesis Quote](#)

## BenchChem

Our mission is to be the trusted global source of essential and advanced chemicals, empowering scientists and researchers to drive progress in science and industry.

### Contact

Address: 3281 E Guasti Rd  
Ontario, CA 91761, United States  
Phone: (601) 213-4426  
Email: [info@benchchem.com](mailto:info@benchchem.com)

[Contact our Ph.D. Support Team for a compatibility check](#)