

# Functionalization of pyridine ring at C5 position using iodine handle

**Author:** BenchChem Technical Support Team. **Date:** May 2026

## Compound of Interest

Compound Name: 5-iodo-2-(1H-pyrrol-1-yl)pyridine

CAS No.: 338748-93-9

Cat. No.: B1621005

[Get Quote](#)

Application Note: Strategic Functionalization of the Pyridine Ring at the C5 Position Using an Iodine Handle

## Executive Summary

The pyridine ring is a privileged scaffold in FDA-approved therapeutics (e.g., Isoniazid, Esomeprazole, Imatinib). However, functionalizing the C5 position (meta to nitrogen) is synthetically challenging due to the ring's electron-deficient nature, which deactivates it toward electrophilic aromatic substitution (

). While Nucleophilic Aromatic Substitution (

) favors C2/C4, the C5 position remains a "blind spot" in many standard libraries.

This guide details the C5-iodine handle strategy. Iodine, possessing a weak C–I bond and high polarizability, serves as a superior reactive handle compared to bromine or chlorine, enabling rapid oxidative addition and low-temperature metal-halogen exchange. This protocol suite provides validated methods for Suzuki-Miyaura coupling, Buchwald-Hartwig amination, and Knochel-type Magnesiation (Turbo-Grignard) specifically optimized for the pyridine core.

# Strategic Analysis: The "Pyridine Problem" & The Iodine Solution

The Challenge:

- **Catalyst Poisoning:** The lone pair on the pyridine nitrogen ( ) strongly coordinates to Pd(II) centers, displacing phosphine ligands and arresting the catalytic cycle (The "Pyridine Effect").
- **Regioselectivity:** In 2-substituted pyridines (common in drug discovery), distinguishing between halogen handles is critical.
- **Anion Instability:** Pyridyl anions generated via Lithium-Halogen exchange are thermally unstable and prone to nucleophilic attack at the C2 position by the alkyllithium itself.

The Solution:

- **Orthogonality:** The C5-I bond reacts significantly faster than C2-Cl or C2-Br bonds in both Pd-catalyzed and metallation reactions, allowing for chemoselective sequential functionalization.
- **Turbo-Grignard:** The use of  $\text{-PrMgCl}\cdot\text{LiCl}$  allows for Iodine-Magnesium exchange at temperatures that suppress side reactions.

## Visual Strategy Map

The following diagram illustrates the divergent pathways accessible from a 5-iodo-2-substituted pyridine core.

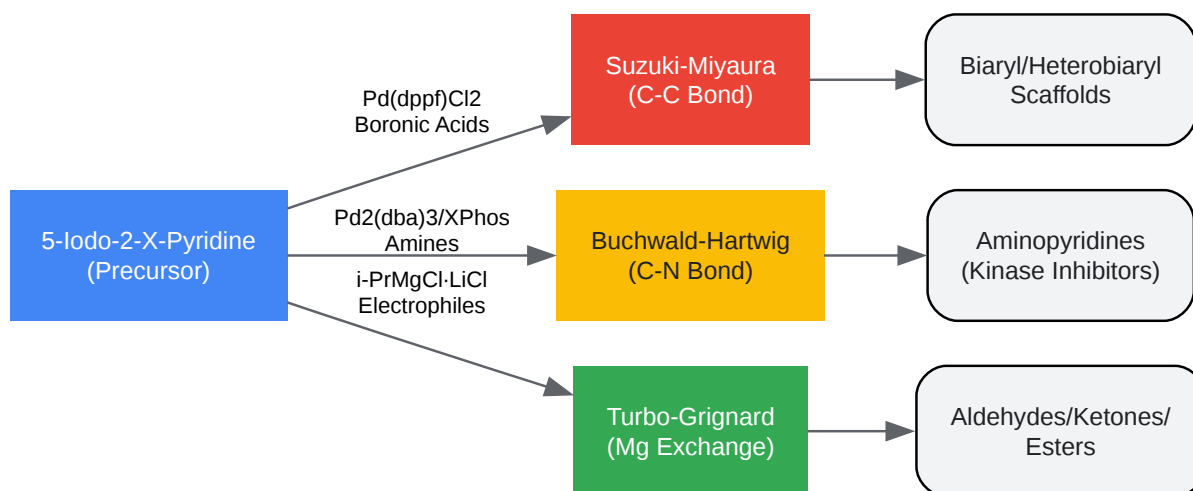

[Click to download full resolution via product page](#)

Figure 1: Divergent synthetic pathways from the C5-Iodine handle.

## Detailed Protocols

### Protocol A: C-C Bond Formation (Suzuki-Miyaura Coupling)

Objective: Coupling 5-iodo-2-chloropyridine with phenylboronic acid. Rationale: The C5-I bond undergoes oxidative addition faster than the C2-Cl bond, preserving the C2-Cl for later functionalization (

).

Reagents & Conditions:

Component	Reagent	Equiv.	Role
Substrate	<b>5-Iodo-2-chloropyridine</b>	<b>1.0</b>	<b>Electrophile</b>
Coupling Partner	Phenylboronic acid	1.2	Nucleophile
Catalyst	Pd(dppf)Cl <sub>2</sub> ·DCM	0.03	Catalyst (Bidentate prevents N-coordination)
Base	K <sub>2</sub> CO <sub>3</sub> (2M aq.)	3.0	Activator

| Solvent | 1,4-Dioxane | - | Solvent (High boiling, coordinates Pd) |

#### Step-by-Step Methodology:

- Inert Setup: Charge a reaction vial with 5-iodo-2-chloropyridine (1.0 mmol), phenylboronic acid (1.2 mmol), and Pd(dppf)Cl<sub>2</sub>·DCM (3 mol%). Seal and purge with Argon for 5 minutes.
  - Expert Note: Pd(dppf)Cl<sub>2</sub> is preferred over Pd(PPh<sub>3</sub>)<sub>4</sub> because the bidentate dppf ligand is less likely to be displaced by the pyridine nitrogen, reducing catalyst deactivation.
- Solvent Addition: Add degassed 1,4-Dioxane (5 mL) and 2M aq. K<sub>2</sub>CO<sub>3</sub> (1.5 mL).
- Reaction: Heat the mixture to 80°C for 4-6 hours. Monitor by LCMS.
  - Checkpoint: The C5-I should be consumed fully. If C2-Cl coupling is observed (rare at 80°C), lower temp to 60°C.
- Workup: Cool to RT. Dilute with EtOAc, wash with water and brine. Dry over Na<sub>2</sub>SO<sub>4</sub>.
- Purification: Flash chromatography (Hexane/EtOAc).

## Protocol B: C-N Bond Formation (Buchwald-Hartwig Amination)

Objective: Amination of 3-iodopyridine (equivalent to C5 in unsubstituted systems) with a secondary amine (e.g., Morpholine). Rationale: Standard bases (NaOtBu) can be risky with

electron-deficient rings (nucleophilic attack). We use specific ligands to facilitate difficult reductive eliminations.[1]

Reagents & Conditions:

Component	Reagent	Equiv.	Role
Substrate	<b>3-Iodopyridine</b>	<b>1.0</b>	<b>Electrophile</b>
Amine	Morpholine	1.2	Nucleophile
Pre-Catalyst	Pd <sub>2</sub> (dba) <sub>3</sub>	0.02	Pd(0) Source
Ligand	XPhos or BrettPhos	0.04	Bulky, electron-rich ligand
Base	NaOtBu	1.4	Base

| Solvent | Toluene or t-Amyl Alcohol | - | Solvent |

Step-by-Step Methodology:

- Catalyst Pre-complexation: In a glovebox or under Argon, mix Pd<sub>2</sub>(dba)<sub>3</sub> and XPhos in Toluene and stir for 10 mins at RT to generate the active catalytic species.
  - Expert Note: For primary amines, use BrettPhos. For secondary amines, XPhos or RuPhos provides higher yields.
- Addition: Add the 3-iodopyridine (1.0 mmol), Morpholine (1.2 mmol), and NaOtBu (1.4 mmol) to the catalyst mixture.
- Reaction: Heat to 100°C for 12 hours in a sealed tube.
- Workup: Filter through a Celite pad (to remove Pd black). Concentrate and purify via silica gel chromatography.

## Protocol C: Metal-Halogen Exchange (The "Turbo-Grignard" Method)

Objective: Formylation of 5-iodo-2-methoxypyridine. Rationale: Direct lithiation (

-BuLi) often attacks the pyridine ring (C2). The Knochel Turbo-Grignard (

-PrMgCl·LiCl) allows exchange at higher temperatures (-15°C) than Li-exchange (-78°C) without ring attack, and the resulting magnesiated species is stable.

Mechanism Visualization:

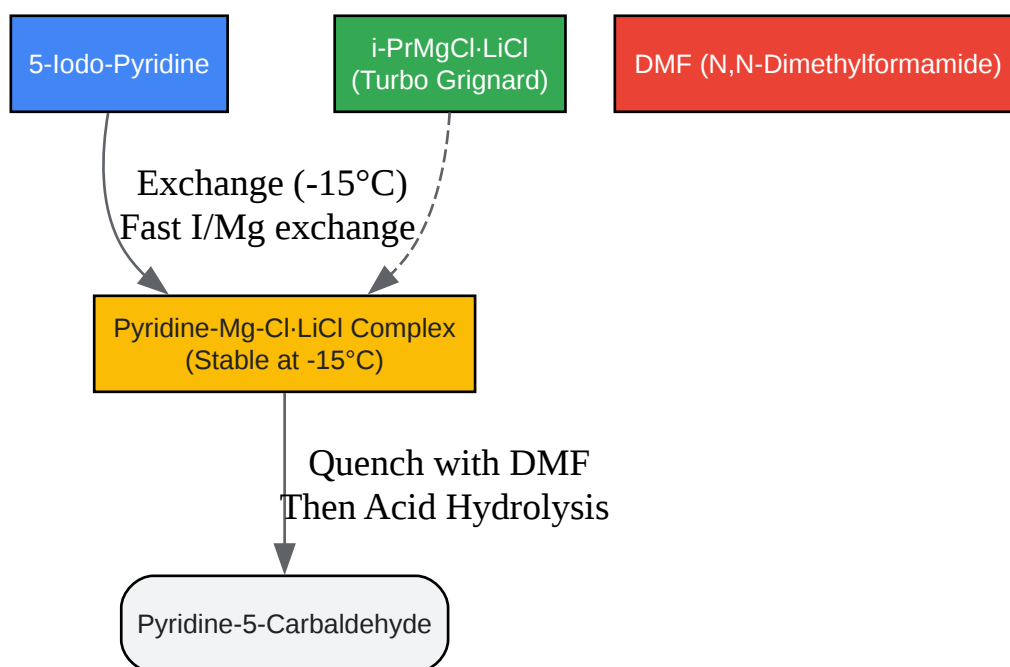

[Click to download full resolution via product page](#)

Figure 2: The Knochel Turbo-Grignard exchange mechanism.

Step-by-Step Methodology:

- Drying: Flame-dry a Schlenk flask under vacuum and backfill with Argon (3 cycles). Moisture kills the Grignard.
- Substrate Loading: Dissolve 5-iodo-2-methoxypyridine (1.0 mmol) in anhydrous THF (5 mL). Cool to -15°C (ice/salt bath).

- Critical Control Point: Do not cool to  $-78^{\circ}\text{C}$  initially. The exchange with Mg is slower than Li;  $-15^{\circ}\text{C}$  to  $0^{\circ}\text{C}$  is the optimal window for rate vs. stability.
- Exchange: Dropwise add  
  
 $-\text{PrMgCl}\cdot\text{LiCl}$  (1.3 M in THF, 1.1 equiv) over 5 minutes. Stir at  $-15^{\circ}\text{C}$  for 30 minutes.
  - Verification: Take an aliquot, quench with  
  
, and check NMR. Disappearance of the I-C5 peak and appearance of D-C5 confirms the anion.
- Electrophile Trapping: Add dry DMF (1.5 equiv) dropwise. Allow the solution to warm to RT over 1 hour.
- Quench: Add sat. aq.  $\text{NH}_4\text{Cl}$ . Extract with  $\text{Et}_2\text{O}$ .
- Result: This yields the C5-formyl pyridine, a versatile handle for reductive aminations.

## Troubleshooting & Expert Insights

Issue	Probable Cause	Corrective Action
Low Yield (Suzuki)	Pd poisoning by Pyridine N	Switch to Pd(dppf)Cl <sub>2</sub> or increase catalyst loading to 5 mol%.
Dehalogenation (Suzuki)	-Hydride elimination from alkyl-Pd	Ensure base is strictly anhydrous if using sensitive boronic acids; switch to dioxane/water.
Ring Addition (Grignard)	Nucleophilic attack at C2	. Use strictly the LiCl complex (Turbo), not standard -PrMgCl.
Incomplete Exchange	Temperature too low	Unlike -BuLi (instant at -78°C), Turbo Grignard requires -15°C to 0°C for complete exchange on deactivated rings.

## References

- Knochel, P., et al. (2004). Functionalization of Pyridines via Magnesium-Halogen Exchange. *Angewandte Chemie International Edition*.
- Surry, D. S., & Buchwald, S. L. (2008). Biaryl Phosphine Ligands in Palladium-Catalyzed Amination. *Journal of the American Chemical Society*.
- Miyaura, N., & Suzuki, A. (1995). Palladium-Catalyzed Cross-Coupling Reactions of Organoboron Compounds. *Chemical Reviews*.
- Bao, W., et al. (2022). Phenylboronic Ester-Activated Aryl Iodide-Selective Buchwald–Hartwig-Type Amination. *ACS Omega*.

### Need Custom Synthesis?

BenchChem offers custom synthesis for rare earth carbides and specific isotopic labeling.

Email: [info@benchchem.com](mailto:info@benchchem.com) or [Request Quote Online](#).

## Sources

- 1. [m.youtube.com](https://m.youtube.com) [[m.youtube.com](https://m.youtube.com)]
- To cite this document: BenchChem. [Functionalization of pyridine ring at C5 position using iodine handle]. BenchChem, [2026]. [Online PDF]. Available at: [<https://www.benchchem.com/product/b1621005/docs#functionalization-of-pyridine-ring-at-c5-position-using-iodine-handle>]

### Disclaimer & Data Validity:

The information provided in this document is for Research Use Only (RUO) and is strictly not intended for diagnostic or therapeutic procedures. While BenchChem strives to provide accurate protocols, we make no warranties, express or implied, regarding the fitness of this product for every specific experimental setup.

**Technical Support:** The protocols provided are for reference purposes. Unsure if this reagent suits your experiment?

**Need Industrial/Bulk Grade?** [Request Custom Synthesis Quote](#)

## BenchChem

Our mission is to be the trusted global source of essential and advanced chemicals, empowering scientists and researchers to drive progress in science and industry.

### Contact

Address: 3281 E Guasti Rd

Ontario, CA 91761, United States

Phone: (601) 213-4426

Email: [info@benchchem.com](mailto:info@benchchem.com)

Contact our Ph.D. Support Team for a compatibility check