

Comparison of derivatization agents for the analysis of 2-arylmalonaldehydes

Author: BenchChem Technical Support Team. **Date:** May 2026

Compound of Interest

Compound Name: 2-(3-Chlorophenyl)malonaldehyde

CAS No.: 74963-16-9

Cat. No.: B1621663

[Get Quote](#)

Comparison Guide: Derivatization Agents for 2-Arylmalonaldehyde Analysis

Executive Summary

2-Arylmalonaldehydes (e.g., 2-phenylmalonaldehyde) are reactive 1,3-dicarbonyl metabolic byproducts often encountered in drug metabolism studies (e.g., NSAIDs) and lipid peroxidation research. Unlike simple aliphatic aldehydes, these compounds exhibit strong keto-enol tautomerism and steric hindrance at the C2 position, rendering standard analysis challenging.

Direct analysis is often precluded by their polarity, volatility, and thermal instability. This guide compares three primary derivatization strategies: PFBHA (for GC-MS), DNPH (for HPLC-UV), and 3-NPH (for LC-MS), providing evidence-based protocols to select the optimal agent for your matrix.

Mechanistic Intelligence: The Analyte Challenge

Before selecting an agent, one must understand the target. 2-Arylmalonaldehydes exist in a dynamic equilibrium. The C2-aryl group stabilizes the enol form through conjugation, making the carbonyl carbons less electrophilic than in simple malondialdehyde (MDA).

- The Trap: Standard aldehyde reagents may react slowly due to steric bulk at C2.
- The Solution: Agents must possess high nucleophilicity (alpha-effect amines) and form products that "lock" the molecule into a stable geometric configuration.

Reaction Pathway Diagram

The following diagram illustrates the competing reaction pathways for a generic 2-arylmalonaldehyde.

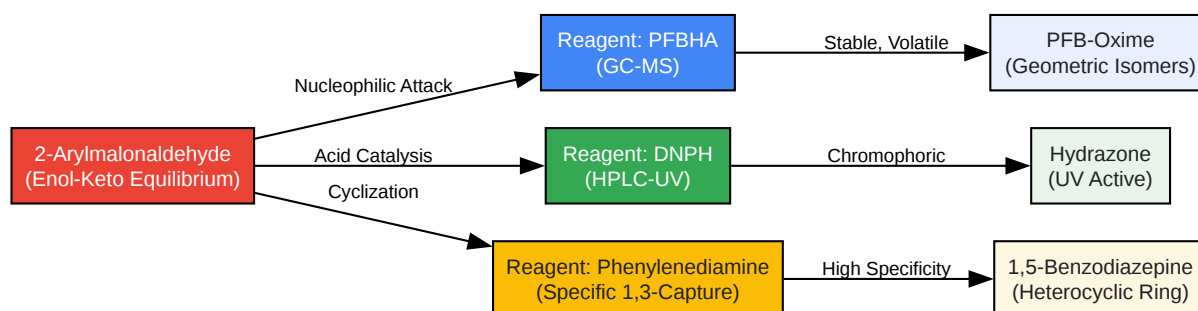

[Click to download full resolution via product page](#)

Caption: Reaction pathways showing how different agents trap the unstable 2-arylmalonaldehyde into detectable forms.

Strategic Comparison of Agents

Agent A: PFBHA (O-(2,3,4,5,6-pentafluorobenzyl)hydroxylamine)

Best For: Trace analysis in complex biological matrices using GC-MS.^{[1][2]}

- Mechanism: Reacts with carbonyls to form oximes. The pentafluorobenzyl group confers high electron capture cross-section, ideal for NICI-MS (Negative Ion Chemical Ionization).

- Pros:
 - Sensitivity: Femtomolar detection limits (10-100x more sensitive than DNPH).
 - Stability: Oximes are thermally stable (up to 250°C).
 - No Acid Required: Reaction proceeds at neutral/mild pH, preserving acid-labile aryl groups.
- Cons:
 - Isomerism: Forms syn and anti isomers, resulting in double peaks for a single analyte, which complicates integration.
 - Cost: Reagent is significantly more expensive than DNPH.

Agent B: DNPH (2,4-Dinitrophenylhydrazine)

Best For: Routine QC, high-concentration samples using HPLC-UV.

- Mechanism: Acid-catalyzed condensation to form hydrazones.
- Pros:
 - Standardization: The EPA Method 8315A gold standard.
 - Robustness: Highly stable derivatives for UV detection (360-365 nm).
 - Equipment: Requires only standard HPLC-UV/DAD, no MS needed.
- Cons:
 - Steric Hindrance: The bulky 2-aryl group can slow the reaction compared to simple aldehydes.
 - pH Risk: Requires strong acid (HCl/H₂SO₄), which may degrade the parent 2-arylmalonaldehyde or induce artifacts.

Agent C: 3-NPH (3-Nitrophenylhydrazine)

Best For: High-throughput drug metabolism studies using LC-MS/MS.

- Mechanism: Similar to DNPH but optimized for ionization efficiency in electrospray ionization (ESI).
- Pros:
 - MS Response: 3-NPH derivatives ionize much better in negative ESI mode than DNPH.
 - Tunability: Can be combined with EDC (carbodiimide) for carboxylic acid byproducts often found alongside aldehydes.
- Cons: Less established spectral libraries compared to DNPH.

Comparative Performance Data

Feature	PFBHA (GC-MS)	DNPH (HPLC-UV)	3-NPH (LC-MS)
LOD (Limit of Detection)	0.5 - 5 nM	50 - 100 nM	1 - 10 nM
Reaction Time	30 - 60 min	60 - 120 min	30 - 60 min
Derivatization pH	pH 4 - 7	pH < 2	pH 4 - 5
Selectivity	High (Mass Spec)	Moderate (UV Co-elution risk)	High (MRM transitions)
Major Challenge	Multiple peaks (Isomers)	Acid stability of analyte	Matrix suppression

Validated Experimental Protocols

Protocol A: High-Sensitivity GC-MS with PFBHA

Use this for plasma or tissue samples where analyte concentration is < 1 µM.

- Preparation: Prepare a 20 mg/mL solution of PFBHA-HCl in HPLC-grade water.

- Reaction:
 - Add 50 μL of sample to a glass vial.
 - Add 200 μL of PFBHA solution.
 - Critical Step: Incubate at room temperature for 1 hour. (Heating $>60^{\circ}\text{C}$ may degrade 2-aryl species).
- Extraction:
 - Add 10 μL of 6N H_2SO_4 (to quench excess reagent) and 500 μL of Hexane.
 - Vortex for 1 min; centrifuge at 3000 rpm.
- Analysis: Inject 1 μL of the upper hexane layer into GC-MS (Splitless).
 - Note: Look for two peaks (syn/anti) and sum their areas for quantification.

Protocol B: Robust HPLC-UV with DNPH

Use this for drug substance purity or stability testing.

- Reagent Setup: Dissolve 50 mg DNPH in 100 mL of Acetonitrile:Water (50:50) containing 1% Phosphoric Acid.
 - Why Phosphoric? It is milder than HCl, reducing degradation of the aryl moiety.
- Reaction:
 - Mix Sample:Reagent in a 1:5 ratio.
 - Incubate at 40°C for 45 minutes.
- Workup:
 - Direct injection is possible if the reagent background is resolved.
 - Otherwise, dilute with mobile phase (Acetonitrile/Water).

- Detection: Monitor at 360 nm.

Decision Matrix (Workflow)

Use the following logic gate to select your method based on laboratory constraints and sensitivity needs.

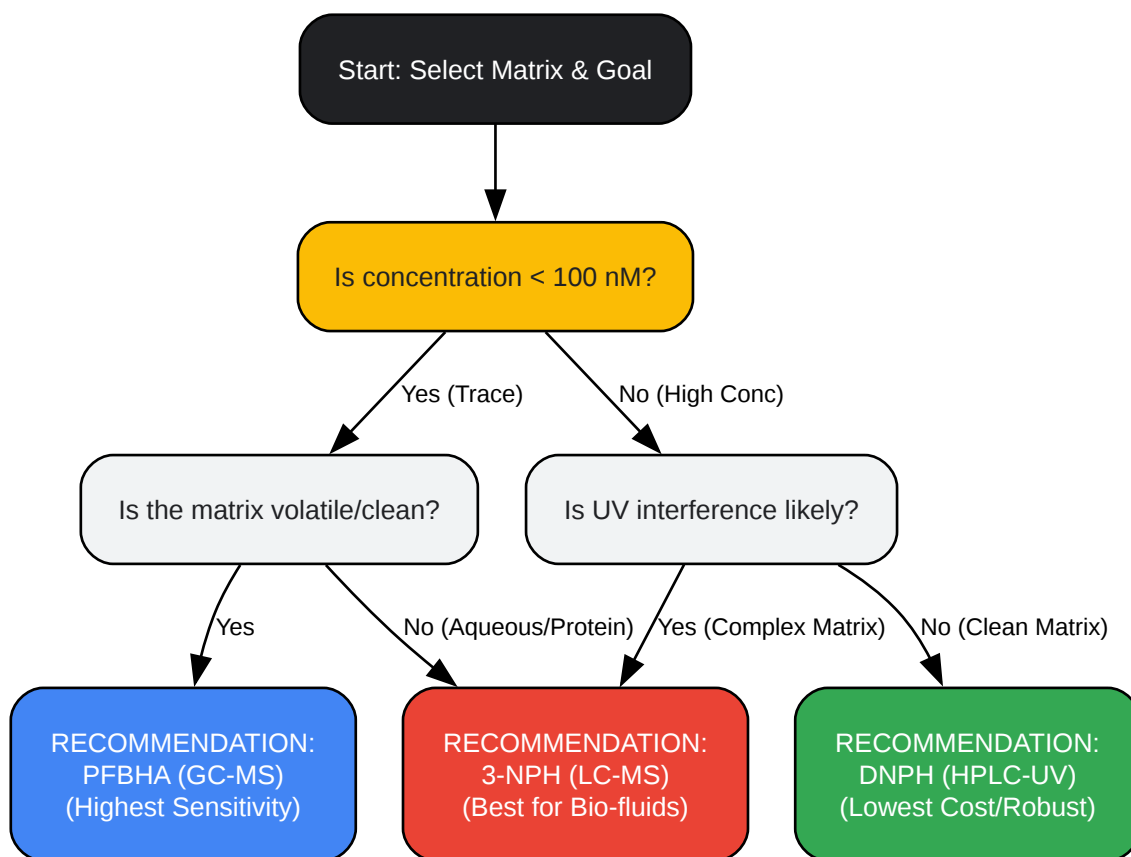

[Click to download full resolution via product page](#)

Caption: Decision tree for selecting the optimal derivatization agent based on sensitivity and matrix complexity.

References

- U.S. Environmental Protection Agency. (1996). Method 8315A: Determination of Carbonyl Compounds by High Performance Liquid Chromatography (HPLC). [Link](#)
- Ligor, M., & Buszewski, B. (2008). Derivatization techniques for the determination of aldehydes and ketones in biological samples. *Journal of Separation Science*. [Link](#)

- Yeo, H. C., et al. (1994). Assay for malondialdehyde in biological fluids by gas chromatography-mass spectrometry. *Analytical Biochemistry*.[\[3\]\[4\]\[5\]\[6\]](#) [Link](#)
- Han, L., et al. (2016). Liquid chromatography-tandem mass spectrometry method for simultaneous measurement of toxic aldehydes. *Journal of Chromatography B*. [Link](#)
- Sigma-Aldrich. (2023). PFBHA: Advantages over derivatization with 2,4-DNPH for Carbonyl Analysis.[\[7\]](#)[Link](#)

Need Custom Synthesis?

BenchChem offers custom synthesis for rare earth carbides and specific isotopic labeling.

Email: info@benchchem.com or [Request Quote Online](#).

Sources

- [1. mdpi.com \[mdpi.com\]](#)
- [2. Bioanalytical and Mass Spectrometric Methods for Aldehyde Profiling in Biological Fluids - PMC \[pmc.ncbi.nlm.nih.gov\]](#)
- [3. Automated derivatization and analysis of malondialdehyde using column switching sample preparation HPLC with fluorescence detection - PubMed \[pubmed.ncbi.nlm.nih.gov\]](#)
- [4. researchgate.net \[researchgate.net\]](#)
- [5. Development and evaluation of a liquid chromatography-tandem mass spectrometry method for simultaneous measurement of toxic aldehydes from brain tissue - PMC \[pmc.ncbi.nlm.nih.gov\]](#)
- [6. LC-MS Quantification of Malondialdehyde-Dansylhydrazine Derivatives in Urine and Serum Samples - PMC \[pmc.ncbi.nlm.nih.gov\]](#)
- [7. mdpi.com \[mdpi.com\]](#)
- To cite this document: BenchChem. [Comparison of derivatization agents for the analysis of 2-arylmalonaldehydes]. BenchChem, [2026]. [Online PDF]. Available at: [\[https://www.benchchem.com/product/b1621663/docs#comparison-of-derivatization-agents-for-the-analysis-of-2-arylmalonaldehydes\]](https://www.benchchem.com/product/b1621663/docs#comparison-of-derivatization-agents-for-the-analysis-of-2-arylmalonaldehydes)

Disclaimer & Data Validity:

The information provided in this document is for Research Use Only (RUO) and is strictly not intended for diagnostic or therapeutic procedures. While BenchChem strives to provide accurate protocols, we make no warranties, express or implied, regarding the fitness of this product for every specific experimental setup.

Technical Support: The protocols provided are for reference purposes. Unsure if this reagent suits your experiment?

Need Industrial/Bulk Grade? [Request Custom Synthesis Quote](#)

BenchChem

Our mission is to be the trusted global source of essential and advanced chemicals, empowering scientists and researchers to drive progress in science and industry.

Contact

Address: 3281 E Guasti Rd
Ontario, CA 91761, United States
Phone: (601) 213-4426
Email: info@benchchem.com

[Contact our Ph.D. Support Team for a compatibility check](#)