

# A Comparative Guide to the Mass Spectrum Fragmentation of 2-Methyl-3-vinylpyrazine

**Author:** BenchChem Technical Support Team. **Date:** April 2026

## Compound of Interest

Compound Name: 2-Methyl-3-vinylpyrazine

CAS No.: 25058-19-9

Cat. No.: B1621205

[Get Quote](#)

For researchers, scientists, and professionals in drug development and flavor chemistry, understanding the mass spectral fragmentation of volatile organic compounds is paramount for accurate identification and structural elucidation. This guide provides an in-depth analysis of the electron ionization (EI) mass spectrometry fragmentation pattern of **2-Methyl-3-vinylpyrazine**, a significant heteroaromatic compound found in various food products. By comparing its fragmentation with structurally similar pyrazines, this document offers a practical framework for interpreting mass spectra in this chemical class.

## Introduction to 2-Methyl-3-vinylpyrazine and its Significance

**2-Methyl-3-vinylpyrazine** (C<sub>7</sub>H<sub>8</sub>N<sub>2</sub>) is a substituted pyrazine with a molecular weight of 120.1518 g/mol. [1] Pyrazines are a class of nitrogen-containing heterocyclic aromatic compounds that are well-known for their potent aroma and flavor characteristics, often associated with roasted, nutty, and Maillard browning reactions in food. [2] Consequently, their accurate identification by methods such as Gas Chromatography-Mass Spectrometry (GC-MS) is crucial in the food and beverage industry for quality control and flavor profile analysis.

This guide will focus on the fragmentation patterns observed under Electron Ionization (EI), a hard ionization technique that provides detailed structural information through characteristic fragmentation.

## The Principles of Electron Ionization Mass Spectrometry (EI-MS) for Pyrazine Analysis

In EI-MS, the analyte molecule is bombarded with high-energy electrons (typically 70 eV), leading to the ejection of an electron and the formation of a molecular ion ( $M^{+\bullet}$ ). This molecular ion is a radical cation that is often unstable and undergoes a series of fragmentation reactions to produce smaller, more stable ions. The resulting mass spectrum is a fingerprint of the molecule, showing the mass-to-charge ratio ( $m/z$ ) of the molecular ion and its various fragment ions, with their relative abundances.

The fragmentation of pyrazine derivatives is influenced by the stability of the aromatic ring and the nature of its substituents. Common fragmentation pathways for alkyl- and vinyl-substituted pyrazines include:

- Loss of a methyl radical ( $\bullet\text{CH}_3$ ): This is a common fragmentation for methyl-substituted pyrazines, leading to an  $[M-15]^+$  ion.
- Loss of hydrogen cyanide (HCN): The pyrazine ring can undergo cleavage, leading to the loss of a neutral HCN molecule, resulting in an  $[M-27]^+$  ion.
- Loss of a vinyl radical ( $\bullet\text{C}_2\text{H}_3$ ): For vinyl-substituted pyrazines, cleavage of the vinyl group can occur, leading to an  $[M-27]^+$  ion.
- Retro-Diels-Alder (RDA) reactions: The pyrazine ring can undergo RDA reactions, leading to characteristic fragment ions.

The relative abundance of these fragment ions is dependent on the stability of the resulting cations and neutral radicals.

## Predicted Mass Spectrum Fragmentation of 2-Methyl-3-vinylpyrazine

While extensive experimental data for **2-Methyl-3-vinylpyrazine** is not widely published, a predicted GC-MS spectrum provides valuable insight into its likely fragmentation pattern under electron ionization.[3]

The molecular ion peak is expected at  $m/z$  120, corresponding to the molecular weight of the compound. The major predicted fragmentation pathways are as follows:

- $[M-1]^+$  at  $m/z$  119: Loss of a hydrogen radical ( $\bullet H$ ), likely from the methyl or vinyl group, to form a stable, conjugated cation.
- $[M-27]^+$  at  $m/z$  93: This significant fragment likely arises from the loss of a neutral molecule of hydrogen cyanide (HCN) from the pyrazine ring, a characteristic fragmentation for nitrogen-containing heterocycles.
- $[M-28]^+$  at  $m/z$  92: This could be due to the loss of a neutral ethene molecule ( $C_2H_4$ ) via a rearrangement reaction.
- $[M-42]^+$  at  $m/z$  78: This fragment could be formed by the loss of a neutral acetonitrile molecule ( $CH_3CN$ ), which is a common fragmentation pathway for methyl-substituted pyrazines.
- Fragment at  $m/z$  53: This ion is likely a  $C_4H_5^+$  species, resulting from the cleavage of the pyrazine ring.

The following diagram illustrates the primary predicted fragmentation pathway for **2-Methyl-3-vinylpyrazine**.

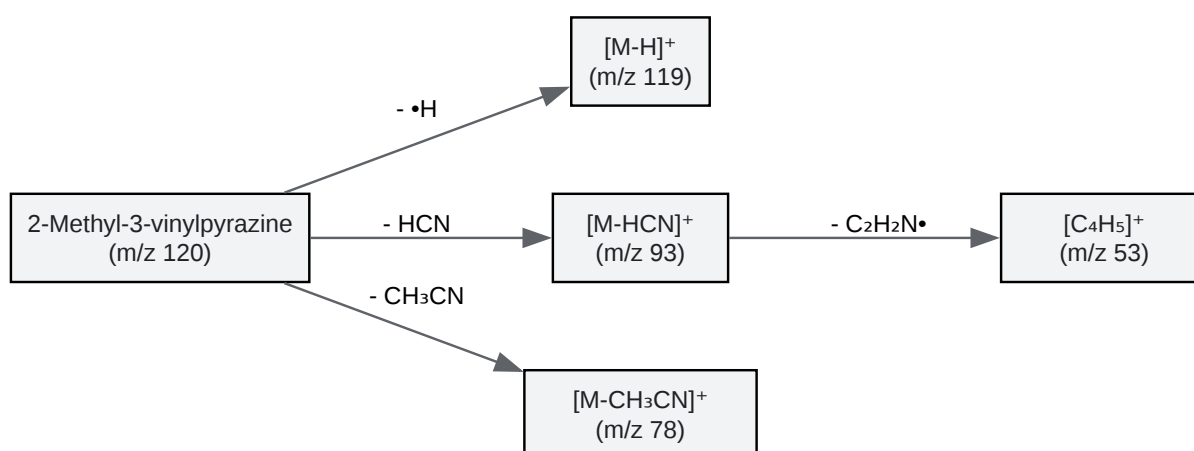

[Click to download full resolution via product page](#)

Caption: Predicted fragmentation of **2-Methyl-3-vinylpyrazine**.

## Comparative Fragmentation Analysis

A powerful approach to confirming the identity of a compound is to compare its mass spectrum with that of its isomers and other closely related structures.

### 2-Methyl-3-vinylpyrazine vs. 2-Methyl-6-vinylpyrazine

2-Methyl-6-vinylpyrazine is a structural isomer of **2-Methyl-3-vinylpyrazine**. Its experimental mass spectrum provides an excellent basis for comparison.

m/z	Predicted Relative Abundance (2-Methyl-3-vinylpyrazine)	Experimental Relative Abundance (2-Methyl-6-vinylpyrazine)	Putative Fragment
120	High	High	Molecular Ion [M] <sup>+</sup> •
119	High	High	[M-H] <sup>+</sup>
94	Moderate	High	[M-C <sub>2</sub> H <sub>2</sub> ] <sup>+</sup>
93	High	Moderate	[M-HCN] <sup>+</sup>
78	Moderate	Low	[M-CH <sub>3</sub> CN] <sup>+</sup>
52	Moderate	High	[C <sub>4</sub> H <sub>4</sub> ] <sup>+</sup>

The most notable difference is the higher abundance of the m/z 94 fragment in 2-methyl-6-vinylpyrazine. This is likely due to a more favorable rearrangement and loss of acetylene (C<sub>2</sub>H<sub>2</sub>) from the vinyl group and the ring in this isomer.

### 2-Methyl-3-vinylpyrazine vs. 2-Ethyl-3-methylpyrazine

Comparing the vinyl-substituted pyrazine with its saturated analogue, 2-ethyl-3-methylpyrazine (MW = 122.17 g/mol), highlights the influence of the vinyl group on fragmentation.[4]

m/z	Predicted Relative Abundance (2-Methyl-3-vinylpyrazine)	Experimental Relative Abundance (2-Ethyl-3-methylpyrazine)	Putative Fragment
122	N/A	High	Molecular Ion [M] <sup>+•</sup>
120	High	N/A	Molecular Ion [M] <sup>+•</sup>
107	N/A	High	[M-CH <sub>3</sub> ] <sup>+</sup>
94	Moderate	High	[M-C <sub>2</sub> H <sub>4</sub> ] <sup>+</sup>
93	High	Moderate	[M-HCN] <sup>+</sup>

The base peak for 2-ethyl-3-methylpyrazine is at m/z 107, corresponding to the loss of a methyl radical ( $\bullet\text{CH}_3$ ), a very common and favorable fragmentation for ethyl-substituted aromatic compounds. This contrasts with the predicted spectrum of **2-methyl-3-vinylpyrazine**, where the loss of a hydrogen radical or HCN is more prominent.

## Experimental Protocol for GC-MS Analysis of Pyrazines

The following is a standard protocol for the analysis of volatile pyrazines in a liquid matrix, such as a food extract or beverage.

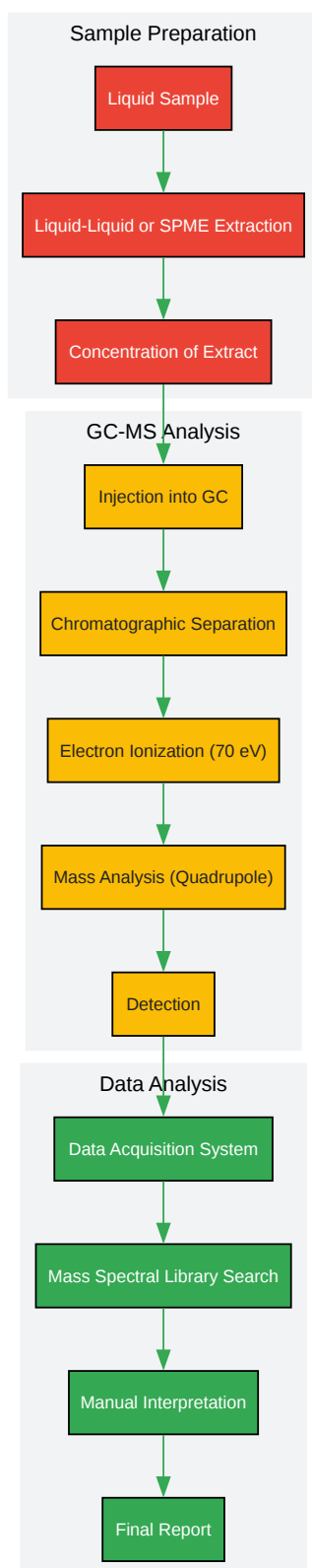

[Click to download full resolution via product page](#)

Caption: GC-MS workflow for pyrazine analysis.

**Step-by-Step Methodology:**

- **Sample Preparation:**
  - For liquid samples, perform a liquid-liquid extraction with a suitable solvent (e.g., dichloromethane).
  - Alternatively, for trace analysis, use solid-phase microextraction (SPME) with a fiber appropriate for volatile and semi-volatile compounds (e.g., PDMS/DVB).
  - Carefully concentrate the extract to a final volume of approximately 1 mL.
- **Gas Chromatography (GC) Conditions:**
  - Injector: Splitless mode, 250°C.
  - Column: A non-polar or medium-polarity column is typically used (e.g., DB-5ms, 30 m x 0.25 mm i.d., 0.25 µm film thickness).
  - Carrier Gas: Helium at a constant flow rate of 1.0 mL/min.
  - Oven Program: Initial temperature of 40°C for 2 minutes, ramp at 10°C/min to 280°C, and hold for 5 minutes.
- **Mass Spectrometry (MS) Conditions:**
  - Ionization Mode: Electron Ionization (EI) at 70 eV.
  - Source Temperature: 230°C.
  - Quadrupole Temperature: 150°C.
  - Scan Range: m/z 40-350.
- **Data Analysis:**
  - Identify peaks in the total ion chromatogram.
  - Compare the mass spectrum of each peak with a reference library (e.g., NIST, Wiley).

- Manually interpret the fragmentation patterns to confirm the identity, especially for isomers with similar spectra.

## Conclusion

The mass spectral fragmentation of **2-Methyl-3-vinylpyrazine**, while not extensively documented with experimental data, can be reliably predicted based on established principles of organic mass spectrometry and comparison with its isomers. The key fragments are expected to arise from the loss of a hydrogen radical, hydrogen cyanide, and acetonitrile. Comparative analysis with isomers like 2-methyl-6-vinylpyrazine and saturated analogues such as 2-ethyl-3-methylpyrazine reveals subtle but important differences in fragmentation patterns that can be used for unambiguous identification. The provided GC-MS protocol offers a robust starting point for the analysis of these and other important flavor compounds.

## References

- National Institute of Standards and Technology. (n.d.). Pyrazine, 2-ethyl-3-methyl-. NIST Chemistry WebBook. Retrieved from [\[Link\]](#)
- FooDB. (2020). Showing Compound **2-Methyl-3-vinylpyrazine** (FDB019671). Retrieved from [\[Link\]](#)
- ResearchGate. (n.d.). Mass spectrum of 2-methyl-6-vinylpyrazine. Retrieved from [\[Link\]](#)
- Identification of alkylpyrazines by gas chromatography mass spectrometry (GC-MS). (2019).
- Mass spectra of tentatively identified pyrazine products. (n.d.). ResearchGate. Retrieved from [\[Link\]](#)
- Metabolites of Key Flavor Compound 2,3,5-Trimethylpyrazine in Human Urine. (2022). *Journal of Agricultural and Food Chemistry*, 70(47), 14859–14867.
- National Institute of Standards and Technology. (n.d.). 2-Methyl-3-vinyl pyrazine. NIST Chemistry WebBook. Retrieved from [\[Link\]](#)

### Need Custom Synthesis?

BenchChem offers custom synthesis for rare earth carbides and specific isotopic labeling.

Email: [info@benchchem.com](mailto:info@benchchem.com) or [Request Quote Online](#).

## Sources

- [1. 2-Methyl-3-vinyl pyrazine \[webbook.nist.gov\]](#)
- [2. researchgate.net \[researchgate.net\]](#)
- [3. Showing Compound 2-Methyl-3-vinylpyrazine \(FDB019671\) - FooDB \[foodb.ca\]](#)
- [4. Pyrazine, 2-ethyl-3-methyl- \[webbook.nist.gov\]](#)
- To cite this document: BenchChem. [A Comparative Guide to the Mass Spectrum Fragmentation of 2-Methyl-3-vinylpyrazine]. BenchChem, [2026]. [Online PDF]. Available at: [<https://www.benchchem.com/product/b1621205/docs#a-comparative-guide-to-the-mass-spectrum-fragmentation-of-2-methyl-3-vinylpyrazine>]

---

### Disclaimer & Data Validity:

The information provided in this document is for Research Use Only (RUO) and is strictly not intended for diagnostic or therapeutic procedures. While BenchChem strives to provide accurate protocols, we make no warranties, express or implied, regarding the fitness of this product for every specific experimental setup.

**Technical Support:** The protocols provided are for reference purposes. Unsure if this reagent suits your experiment?

**Need Industrial/Bulk Grade?** [Request Custom Synthesis Quote](#)

# BenchChem

Our mission is to be the trusted global source of essential and advanced chemicals, empowering scientists and researchers to drive progress in science and industry.

## Contact

Address: 3281 E Guasti Rd

Ontario, CA 91761, United States

Phone: (601) 213-4426

Email: [info@benchchem.com](mailto:info@benchchem.com)

[Contact our Ph.D. Support Team for a compatibility check](#)