

# (4-Bromophenyl) methanesulfonate physical properties

**Author:** BenchChem Technical Support Team. **Date:** May 2026

## Compound of Interest

Compound Name:	(4-Bromophenyl) methanesulfonate
CAS No.:	68574-35-6
Cat. No.:	B1621078

[Get Quote](#)

## An In-depth Technical Guide to the Physicochemical Properties of (4-Bromophenyl) methanesulfonate

A Note on Chemical Identity: The name "**(4-Bromophenyl) methanesulfonate**" can be ambiguous. It may refer to the ester, 4-bromophenyl methanesulfonate (CAS 68574-35-6), or the isomeric sulfonamide, N-(4-bromophenyl)methanesulfonamide (CAS 4284-50-8). Given the profound importance of the sulfonamide moiety in therapeutic drug design, this guide will focus on N-(4-Bromophenyl)methanesulfonamide. This compound serves as a valuable building block for researchers in medicinal chemistry and drug development.

## Core Physicochemical and Structural Properties

N-(4-Bromophenyl)methanesulfonamide is an organic compound featuring a methanesulfonyl group bonded to the nitrogen of a 4-bromoaniline core.[1] This structure imparts a unique combination of properties, making it a subject of interest for further chemical modification and biological screening. The presence of the sulfonamide group allows it to act as a hydrogen bond donor, a critical feature for molecular recognition at biological targets.[2]

The key identifiers and physical properties are summarized below for quick reference.

Property	Value	Source(s)
CAS Number	4284-50-8	[3]
Molecular Formula	C <sub>7</sub> H <sub>8</sub> BrNO <sub>2</sub> S	[1][3]
Molecular Weight	250.11 g/mol	[1][3]
Appearance	White to off-white solid/powder	[3]
Melting Point	137-141 °C	[3]
Boiling Point	333.0 ± 44.0 °C (Predicted)	[3]
Density	1.711 ± 0.06 g/cm <sup>3</sup> (Predicted)	[3]
Solubility	Soluble in polar solvents like water and alcohols	[1]
pKa	7.62 ± 0.10 (Predicted)	[3]

## Molecular Structure Diagram

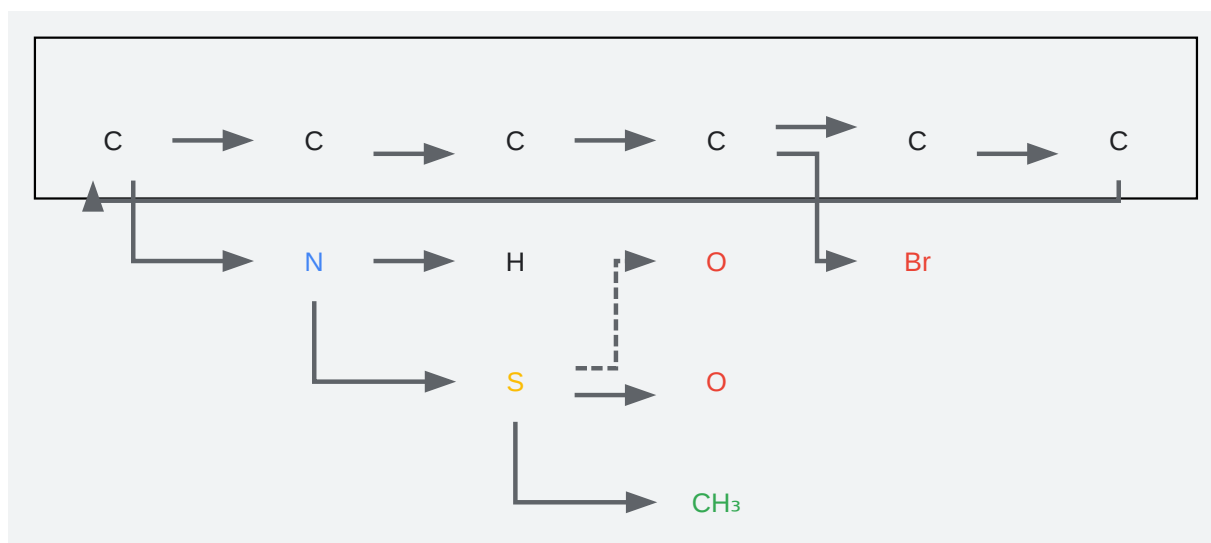

[Click to download full resolution via product page](#)

Caption: Molecular structure of N-(4-Bromophenyl)methanesulfonamide.

## Spectroscopic Analysis

Spectroscopic data is crucial for the unambiguous identification and quality control of N-(4-Bromophenyl)methanesulfonamide.

### Nuclear Magnetic Resonance (NMR) Spectroscopy

- $^1\text{H}$  NMR: The proton NMR spectrum is expected to show distinct signals. The methyl protons ( $\text{CH}_3$ ) of the methanesulfonyl group would appear as a sharp singlet, typically downfield due to the electron-withdrawing nature of the  $\text{SO}_2$  group. The aromatic protons on the para-substituted ring will present as a classic AA'BB' system, appearing as two doublets. The N-H proton will be a broad singlet, and its chemical shift can be variable depending on the solvent and concentration.
- $^{13}\text{C}$  NMR: The carbon NMR spectrum will show four signals for the aromatic carbons and one for the methyl carbon.[4] The carbon attached to the bromine atom (ipso-carbon) is influenced by the "heavy atom effect," which can cause an upfield shift compared to what would be expected based on electronegativity alone.[5] The carbon attached to the nitrogen will also be shifted. The remaining two aromatic carbons will have distinct chemical shifts, and the methyl carbon will appear at the high-field end of the spectrum.

### Infrared (IR) Spectroscopy

The IR spectrum provides key information about the functional groups present.[6]

- N-H Stretch: A characteristic sharp to medium absorption band is expected in the region of  $3200\text{-}3400\text{ cm}^{-1}$ , corresponding to the N-H stretching vibration of the sulfonamide.
- S=O Stretches: Two strong absorption bands will be present, corresponding to the asymmetric and symmetric stretching of the S=O bonds in the sulfonyl group. These typically appear around  $1350\text{-}1310\text{ cm}^{-1}$  (asymmetric) and  $1170\text{-}1140\text{ cm}^{-1}$  (symmetric).[6]
- Aromatic C-H and C=C Stretches: Standard absorptions for the aromatic ring will be observed above  $3000\text{ cm}^{-1}$  (C-H) and in the  $1600\text{-}1450\text{ cm}^{-1}$  region (C=C).

## Mass Spectrometry (MS)

Mass spectrometry confirms the molecular weight and provides fragmentation patterns. The predicted monoisotopic mass is 248.9459 Da.[7] High-resolution mass spectrometry would show the characteristic isotopic pattern of bromine ( $^{19}\text{Br}$  and  $^{81}\text{Br}$  in an approximate 1:1 ratio), resulting in two major peaks (M and M+2) of nearly equal intensity.

## Synthesis Protocol

The most common and direct synthesis of N-(4-Bromophenyl)methanesulfonamide involves the reaction of 4-bromoaniline with methanesulfonyl chloride.[1] This is a standard nucleophilic substitution at the sulfonyl sulfur.

## Synthesis Workflow Diagram

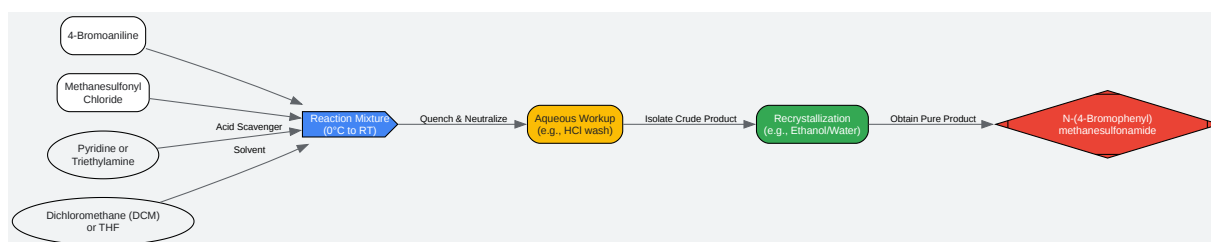

[Click to download full resolution via product page](#)

Caption: General workflow for the synthesis of N-(4-Bromophenyl)methanesulfonamide.

## Step-by-Step Methodology

- **Dissolution:** In a round-bottom flask under an inert atmosphere (e.g., nitrogen), dissolve 4-bromoaniline (1.0 eq.) in a suitable anhydrous solvent such as dichloromethane (DCM) or tetrahydrofuran (THF).

- **Addition of Base:** Add a non-nucleophilic base, such as pyridine or triethylamine (1.1-1.2 eq.), to the solution. The purpose of the base is to neutralize the hydrochloric acid (HCl) byproduct that is generated during the reaction, preventing it from protonating the starting aniline and stopping the reaction.
- **Cooling:** Cool the reaction mixture to 0 °C using an ice bath. This is a crucial step to control the exothermicity of the reaction upon adding the highly reactive sulfonyl chloride.
- **Addition of Sulfonyl Chloride:** Add methanesulfonyl chloride (1.0-1.1 eq.) dropwise to the stirred solution, ensuring the temperature remains low.
- **Reaction:** After the addition is complete, allow the reaction mixture to slowly warm to room temperature and stir for several hours (typically 2-18 hours) until the reaction is complete, as monitored by Thin Layer Chromatography (TLC).
- **Workup:** Quench the reaction by adding water. If DCM is the solvent, transfer the mixture to a separatory funnel. Wash the organic layer sequentially with a dilute acid (e.g., 1M HCl) to remove excess base, followed by water and brine.
- **Isolation and Purification:** Dry the organic layer over an anhydrous drying agent (e.g., Na<sub>2</sub>SO<sub>4</sub> or MgSO<sub>4</sub>), filter, and remove the solvent under reduced pressure. The resulting crude solid is typically purified by recrystallization from a suitable solvent system, such as ethanol/water, to yield the pure N-(4-Bromophenyl)methanesulfonamide.

## Applications in Research and Drug Development

The sulfonamide functional group is a well-established pharmacophore found in a wide range of clinically approved drugs, including antibacterials, diuretics, and kinase inhibitors.[2] N-(4-Bromophenyl)methanesulfonamide serves as a key intermediate and building block in the synthesis of more complex, biologically active molecules.[8]

- **Scaffold for Library Synthesis:** The bromine atom provides a reactive handle for further functionalization via cross-coupling reactions, such as the Suzuki-Miyaura reaction.[9] This allows for the rapid generation of a library of diverse analogs for structure-activity relationship (SAR) studies.

- **Potential Biological Activity:** As a standalone molecule, it has been noted for potential antibacterial or antitumor properties, though specific high-potency examples are part of broader drug discovery programs.[1] Its derivatives are explored for a wide range of therapeutic applications.[2]
- **Kinase Inhibitor Development:** The N-arylsulfonamide motif is a common feature in many kinase inhibitors, where it can form critical hydrogen bonds within the ATP-binding pocket of the enzyme.[2][8] This compound provides a ready-made fragment for incorporation into novel kinase inhibitor designs.

## Safety and Handling

Proper handling of N-(4-Bromophenyl)methanesulfonamide is essential in a laboratory setting. Based on available safety data, the compound presents the following hazards:

- **Hazard Statements:** H302 (Harmful if swallowed), H315 (Causes skin irritation), H319 (Causes serious eye irritation), H335 (May cause respiratory irritation).[10]
- **Precautionary Measures:**
  - **Engineering Controls:** Use only in a well-ventilated area, preferably in a chemical fume hood.[11]
  - **Personal Protective Equipment (PPE):** Wear protective gloves, chemical safety goggles, and a lab coat.[11][12]
  - **Handling:** Avoid breathing dust. Avoid contact with skin and eyes. Wash hands thoroughly after handling.[12][13]
  - **Storage:** Store in a tightly closed container in a dry, cool, and well-ventilated place.[12]

Always consult the specific Safety Data Sheet (SDS) provided by the supplier before handling this chemical.

## References

- PubChemLite. (n.d.). N-(4-bromophenyl)methanesulfonamide (C7H8BrNO2S). Retrieved from [\[Link\]](#)

- ResearchGate. (2020). FT-IR spectrum of N-(4-bromophenyl)-N-cyano-4-methylbenzenesulfonamide. Retrieved from [\[Link\]](#)
- National Center for Biotechnology Information. (n.d.). N-(4-((4-Bromophenyl)amino)sulfonyl)phenyl)acetamide. PubChem Compound Summary for CID 984584. Retrieved from [\[Link\]](#)
- Royal Society of Chemistry. (n.d.). Supporting information. Retrieved from [\[Link\]](#)
- Bolli, M. H., et al. (2012). The Discovery of N-[5-(4-Bromophenyl)-6-[2-[(5-bromo-2-pyrimidinyl)oxy]ethoxy]-4-pyrimidinyl]-N'-propylsulfamide (Macitentan), an Orally Active, Potent Dual Endothelin Receptor Antagonist. *Journal of Medicinal Chemistry*. Retrieved from [\[Link\]](#)
- PubChemLite. (n.d.). (4-bromophenyl)methanesulfonamide (C7H8BrNO2S). Retrieved from [\[Link\]](#)
- Khan, I., et al. (2022). Synthesis of Functionalized N-(4-Bromophenyl)furan-2-carboxamides via Suzuki-Miyaura Cross-Coupling: Anti-Bacterial Activities against Clinically Isolated Drug Resistant *A. baumannii*, *K. pneumoniae*, *E. cloacae* and MRSA and Its Validation via a Computational Approach. *Molecules*, 27(14), 4409. Retrieved from [\[Link\]](#)
- Banaras Hindu University. (n.d.). Synthesis of amides directly from carboxylic acids and hydrazines - Supporting Information. Retrieved from [\[Link\]](#)
- Hart, B. T., & Sivasothy, R. (2007). Infrared and NMR Spectra of Arylsulphonamides, 4-X-C6H4SO2NH2 and i-X, j-YC6H3SO2NH2.
- Oregon State University. (2022). 13C NMR Chemical Shift. Retrieved from [\[Link\]](#)
- NIST. (n.d.). Acetamide, N-(4-bromophenyl)-. NIST Chemistry WebBook. Retrieved from [\[Link\]](#)
- NIST. (n.d.). IR Spectrum of Acetamide, N-(4-bromophenyl)-. NIST Chemistry WebBook. Retrieved from [\[Link\]](#)
- SpectraBase. (n.d.). 4'-(bromoacetyl)methanesulfonanilide. Retrieved from [\[Link\]](#)

- Xi'an Baina Biotechnology Co., Ltd. (n.d.). N-(4-bromophenyl)methanesulfonamide. Retrieved from [[Link](#)]
- Chemistry Stack Exchange. (2018). Assigning the <sup>13</sup>C NMR spectrum of bromobenzene and 4-bromobenzophenone. Retrieved from [[Link](#)]
- ResearchGate. (2025). Mild and General Method for the Synthesis of Sulfonamides. Retrieved from [[Link](#)]
- ResearchGate. (n.d.). <sup>1</sup>H-NMR spectrum of N-[(E)-(4-bromophenyl) methylidene]-4-nitroaniline. Retrieved from [[Link](#)]

### Need Custom Synthesis?

BenchChem offers custom synthesis for rare earth carbides and specific isotopic labeling.

Email: [info@benchchem.com](mailto:info@benchchem.com) or [Request Quote Online](#).

## Sources

1. CAS 4284-50-8: N-(4-Bromophenyl)methanesulfonamide [[cymitquimica.com](https://cymitquimica.com)]
2. [pdf.benchchem.com](https://pdf.benchchem.com) [[pdf.benchchem.com](https://pdf.benchchem.com)]
3. N-(4-BROMOPHENYL)METHANESULFONAMIDE, 97% | 4284-50-8 [[m.chemicalbook.com](https://m.chemicalbook.com)]
4. <sup>13</sup>C NMR Chemical Shift [[sites.science.oregonstate.edu](https://sites.science.oregonstate.edu)]
5. [chemistry.stackexchange.com](https://chemistry.stackexchange.com) [[chemistry.stackexchange.com](https://chemistry.stackexchange.com)]
6. [znaturforsch.com](https://znaturforsch.com) [[znaturforsch.com](https://znaturforsch.com)]
7. PubChemLite - N-(4-bromophenyl)methanesulfonamide (C<sub>7</sub>H<sub>8</sub>BrNO<sub>2</sub>S) [[pubchemlite.lcsb.uni.lu](https://pubchemlite.lcsb.uni.lu)]
8. [pdf.benchchem.com](https://pdf.benchchem.com) [[pdf.benchchem.com](https://pdf.benchchem.com)]
9. [mdpi.com](https://mdpi.com) [[mdpi.com](https://mdpi.com)]
10. 4284-50-8 | N-(4-Bromophenyl)methanesulfonamide - AiFChem [[aifchem.com](https://aifchem.com)]
11. [assets.thermofisher.com](https://assets.thermofisher.com) [[assets.thermofisher.com](https://assets.thermofisher.com)]
12. [tcichemicals.com](https://tcichemicals.com) [[tcichemicals.com](https://tcichemicals.com)]

- [13. fishersci.ca \[fishersci.ca\]](https://www.fishersci.ca)
- To cite this document: BenchChem. [(4-Bromophenyl) methanesulfonate physical properties]. BenchChem, [2026]. [Online PDF]. Available at: [<https://www.benchchem.com/product/b1621078/docs#4-bromophenyl-methanesulfonate-physical-properties>]

---

### Disclaimer & Data Validity:

The information provided in this document is for Research Use Only (RUO) and is strictly not intended for diagnostic or therapeutic procedures. While BenchChem strives to provide accurate protocols, we make no warranties, express or implied, regarding the fitness of this product for every specific experimental setup.

**Technical Support:** The protocols provided are for reference purposes. Unsure if this reagent suits your experiment?

**Need Industrial/Bulk Grade?** [Request Custom Synthesis Quote](#)

## BenchChem

Our mission is to be the trusted global source of essential and advanced chemicals, empowering scientists and researchers to drive progress in science and industry.

### Contact

Address: 3281 E Guasti Rd  
Ontario, CA 91761, United States  
Phone: (601) 213-4426  
Email: [info@benchchem.com](mailto:info@benchchem.com)

[Contact our Ph.D. Support Team for a compatibility check](#)