

Technical Support Center: Optimization of o-Amino Ketone Cyclization

Author: BenchChem Technical Support Team. **Date:** May 2026

Compound of Interest

Compound Name: 1-(2-Amino-4-bromophenyl)propan-1-one
CAS No.: 36372-62-0
Cat. No.: B1620726

[Get Quote](#)

Topic: Minimizing Side Products in Friedländer & Related Quinoline Syntheses Ticket ID: CHEM-SUP-90210 Assigned Specialist: Dr. A. Vance, Senior Application Scientist

Executive Summary & Diagnostic Logic

Welcome to the Technical Support Center. You are likely here because your cyclization of o-amino ketones (Friedländer synthesis or similar) is yielding tarry mixtures, recovering starting material, or producing regioisomeric impurities rather than the desired quinoline scaffold.

The cyclization of o-amino ketones is thermodynamically driven but kinetically treacherous. The core challenge is that your ketone coupling partner is often more reactive toward self-condensation (Aldol) than it is toward the sterically hindered o-amino ketone.

Diagnostic Flowchart

Before modifying your protocol, use this logic tree to identify your specific failure mode.

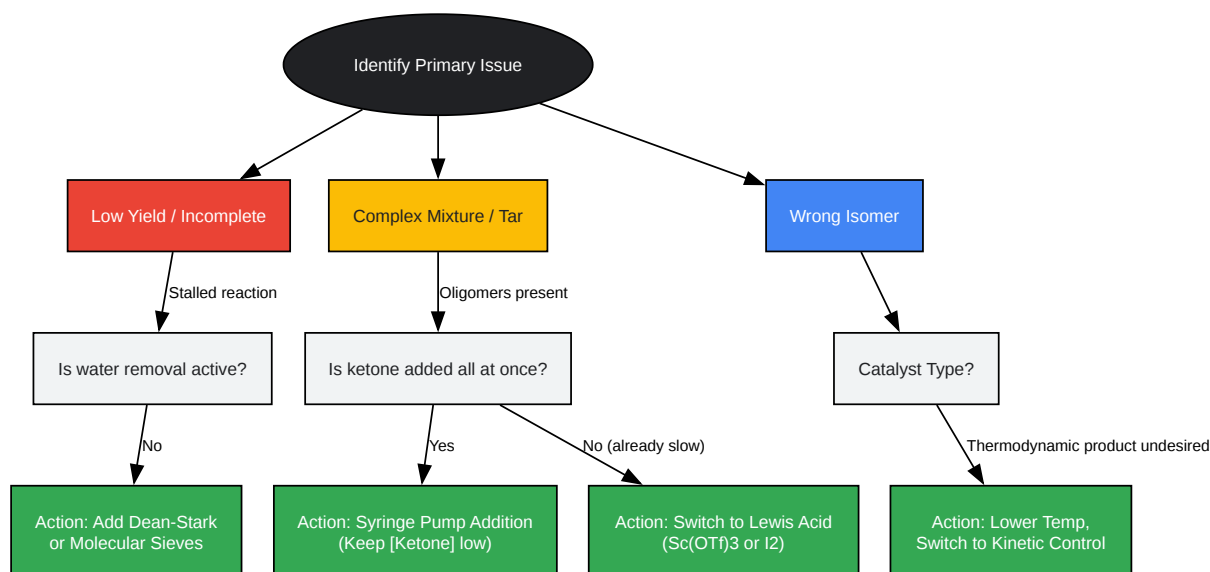

[Click to download full resolution via product page](#)

Figure 1: Diagnostic logic for identifying the root cause of Friedländer cyclization failure.

Core Protocol: The "Clean" Cyclization System

Traditional methods use strong bases (KOH) or mineral acids (H₂SO₄) at high temperatures. These are "sledgehammer" approaches that promote polymerization.

Recommendation: Switch to a Molecular Iodine (

) Catalyzed or Lewis Acid protocol. These are milder, tolerate functional groups better, and minimize aldol side-reactions.

Optimized Protocol (Iodine-Mediated)

Applicability: General synthesis of quinolines from o-amino ketones and

-methylene ketones.

Reagents:

- o-Amino ketone (1.0 equiv)
- Coupling Ketone (1.2 equiv)
- Molecular Iodine () (1–5 mol%)
- Solvent: Ethanol (Green) or Acetonitrile (if solubility is poor). Solvent-free is possible for liquid ketones.

Step-by-Step Workflow:

- Preparation: Dissolve o-amino ketone in Ethanol (0.5 M concentration).
- Catalyst Activation: Add molecular iodine (, 5 mol%). Stir for 5 minutes at room temperature.
 - Why? Iodine acts as a mild Lewis acid to activate the carbonyl without generating hard enolates that lead to polymerization.
- Controlled Addition: Add the coupling ketone.
 - Critical Step: If the coupling ketone is prone to self-condensation (e.g., acetone, acetaldehyde), add it dropwise over 30 minutes.
- Reaction: Stir at room temperature. If no reaction after 1 hour, heat to 50°C.
 - Monitoring: Check TLC.^[1] Look for the disappearance of the blue fluorescent spot of the o-amino ketone.
- Quench: Once complete, add saturated (sodium thiosulfate) to remove iodine (color changes from dark red/brown to yellow/clear).

- Isolation: Extract with Ethyl Acetate. The product is usually high purity; recrystallize from EtOH if needed.

Technical FAQ & Troubleshooting

Direct answers to specific failure modes.

Q1: I am getting a "tarry" black mixture. What is happening?

Diagnosis: You are likely witnessing the uncontrolled polymerization of your

-methylene ketone partner. The Mechanism: In strong base/acid, the coupling ketone forms an enolate/enol that reacts with itself (Self-Aldol) faster than it reacts with the bulky o-amino ketone. These aldol oligomers eventually dehydrate into complex tars. Corrective Action:

- Stoichiometry Control: Do not dump excess ketone into the pot. Use a syringe pump to keep the concentration of the free coupling ketone low relative to the o-amino ketone.

- Switch Catalyst: Move away from KOH/NaOH. Use

or

. These catalysts activate the o-amino ketone carbonyl (electrophile) rather than generating a high concentration of ketone enolate (nucleophile) [1].

Q2: The reaction stalls at 60-70% conversion.

Diagnosis: Water accumulation is inhibiting the dehydration step. The Mechanism: The Friedländer synthesis releases two molecules of water. As water concentration increases, the equilibrium pushes back toward the intermediate aldol adduct or hydrolyzes the imine intermediate. Corrective Action:

- Chemical Drying: Add activated 4Å Molecular Sieves to the reaction flask.
- Azeotropic Removal: If using toluene/benzene, use a Dean-Stark trap.
- Microwave Irradiation: Microwave heating often overcomes this equilibrium barrier by superheating the solvent and accelerating the forward rate constant [2].

Q3: I used 2-butanone and got a mixture of two isomers. How do I control Regioselectivity?

Diagnosis: You are fighting the battle between Kinetic (terminal methyl attack) and Thermodynamic (internal methylene attack) enolization.

- Kinetic Product: Attacks at the less hindered methyl group (Position 1).
- Thermodynamic Product: Attacks at the more substituted methylene group (Position 3).

Corrective Action:

- For Linear Isomer (Kinetic): Use a sterically hindered base (LDA, -78°C) to pre-form the enolate of the ketone, then add the o-amino ketone. This is a stepwise modification of the Friedländer.
- For Branched Isomer (Thermodynamic): Run the standard Friedländer at higher temperatures (reflux) with Acid catalysis (p-TSA). Acid conditions promote the equilibration of the enol to the more stable (more substituted) alkene, leading to the internal attack [3].

Comparative Data: Catalyst Efficiency

The choice of catalyst drastically affects the "Atom Economy" (yield vs. side products).

Catalyst System	Typical Yield	Reaction Time	Side Product Profile	Notes
NaOH / EtOH (Reflux)	45–65%	4–12 h	High (Aldol polymers)	Classical method. Harsh. Poor for sensitive substrates.
H ₂ SO ₄ / AcOH (Reflux)	60–75%	2–6 h	Moderate (Charring)	Good for simple substrates. Acid sensitive groups degrade.
Molecular Iodine ()	85–95%	1–3 h	Low	Mild, neutral conditions. Easy workup (thiosulfate wash) [4].
Sc(OTf) ₃ (Lewis Acid)	90–98%	1–4 h	Very Low	Reusable catalyst. Excellent for high-value drug intermediates.
Ionic Liquids	80–90%	<1 h	Low	Green solvent, but expensive and hard to remove traces.

Mechanistic Visualization

Understanding the competition between the Desired Pathway (Cross-Condensation) and the Parasitic Pathway (Self-Condensation) is vital.

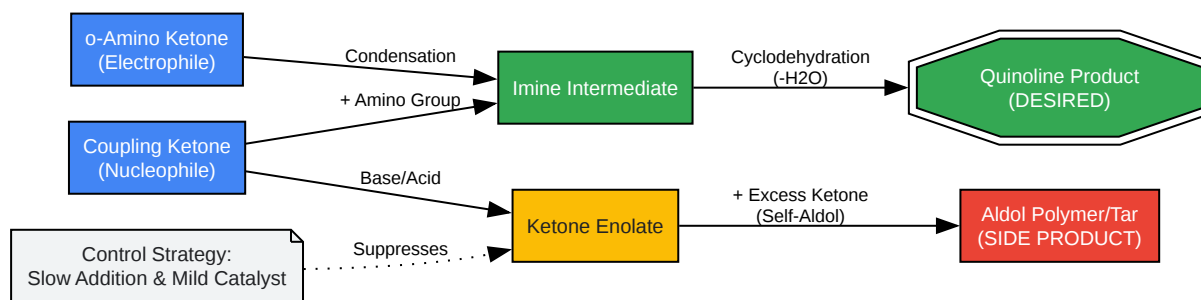

[Click to download full resolution via product page](#)

Figure 2: Competitive pathways. High concentrations of 'Coupling Ketone' favor the red path (Polymer). Controlled addition favors the green path (Quinoline).

References

- BenchChem.Troubleshooting low yield in Friedländer synthesis of quinolines. (2025).[1][2][3][4]
- Organic Chemistry Portal.Friedlaender Synthesis: Mechanism and Recent Literature. (2025). [1][2][3][4]
- Master Organic Chemistry.Aldol Addition and Condensation Reactions: Kinetics vs Thermodynamics. (2022).[2][5][6][7]
- Wu, J., et al.Molecular iodine: a highly efficient catalyst in the synthesis of quinolines via Friedländer annulation.[8] Organic & Biomolecular Chemistry, 4, 126-129.[8] (2006).
- Alfa Chemistry.Friedländer Quinoline Synthesis: Catalysts and Experimental Tips. (2025).[1][2][3][4]

Need Custom Synthesis?

BenchChem offers custom synthesis for rare earth carbides and specific isotopic labeling.

Email: info@benchchem.com or [Request Quote Online](#).

Sources

- [1. pdf.benchchem.com](https://pdf.benchchem.com) [pdf.benchchem.com]
- [2. mdpi.com](https://mdpi.com) [mdpi.com]
- [3. researchgate.net](https://researchgate.net) [researchgate.net]
- [4. mdpi.com](https://mdpi.com) [mdpi.com]
- [5. masterorganicchemistry.com](https://masterorganicchemistry.com) [masterorganicchemistry.com]
- [6. Quinoline synthesis](https://organic-chemistry.org) [organic-chemistry.org]
- [7. pdfs.semanticscholar.org](https://pdfs.semanticscholar.org) [pdfs.semanticscholar.org]
- [8. Friedlaender Synthesis](https://organic-chemistry.org) [organic-chemistry.org]
- To cite this document: BenchChem. [Technical Support Center: Optimization of o-Amino Ketone Cyclization]. BenchChem, [2026]. [Online PDF]. Available at: [<https://www.benchchem.com/product/b1620726/docs#technical-support-center-optimization-of-o-amino-ketone-cyclization>]

Disclaimer & Data Validity:

The information provided in this document is for Research Use Only (RUO) and is strictly not intended for diagnostic or therapeutic procedures. While BenchChem strives to provide accurate protocols, we make no warranties, express or implied, regarding the fitness of this product for every specific experimental setup.

Technical Support: The protocols provided are for reference purposes. Unsure if this reagent suits your experiment?

Need Industrial/Bulk Grade? [Request Custom Synthesis Quote](#)

BenchChem

Our mission is to be the trusted global source of essential and advanced chemicals, empowering scientists and researchers to drive progress in science and industry.

Contact

Address: 3281 E Guasti Rd

Ontario, CA 91761, United States

Phone: (601) 213-4426

Email: info@benchchem.com

[Contact our Ph.D. Support Team for a compatibility check](#)