

# Technical Guide: Mass Spectrometry Fragmentation of 2-Chloro-5-ethoxy-4- propoxybenzaldehyde

**Author:** BenchChem Technical Support Team. **Date:** April 2026

## Compound of Interest

Compound Name:	2-Chloro-5-ethoxy-4-propoxybenzaldehyde
CAS No.:	692275-23-3
Cat. No.:	B1620595

[Get Quote](#)

## Executive Summary

This guide provides a comprehensive analysis of the mass spectrometry (MS) fragmentation behavior of **2-Chloro-5-ethoxy-4-propoxybenzaldehyde** (CAS: 692275-23-3). As a critical intermediate in the synthesis of novel phosphodiesterase inhibitors and kinase antagonists, precise structural characterization of this molecule is essential for impurity profiling and quality control.

This document compares the Electron Ionization (EI) performance of this molecule against its structural isomers and homologs, establishing a self-validating protocol for its unambiguous identification.

## Chemical Identity & Theoretical Basis[1]

Before analyzing the fragmentation, we must establish the physicochemical baseline.

Property	Specification
Chemical Name	2-Chloro-5-ethoxy-4-propoxybenzaldehyde
Formula	C <sub>12</sub> H <sub>15</sub> ClO <sub>3</sub>
Exact Mass (Monoisotopic)	242.0710 Da ( <sup>35</sup> Cl)
Molecular Weight	242.70 g/mol
Key Functional Groups	Aryl Chloride, Benzaldehyde, Ethyl Ether, Propyl Ether
Isotope Signature	Distinct <sup>35</sup> Cl/ <sup>37</sup> Cl ratio (3:1) at m/z 242/244

## The Structural Challenge

The primary analytical challenge lies in differentiating this molecule from its regioisomers (e.g., 2-Chloro-4-ethoxy-5-propoxybenzaldehyde) and homologs (e.g., 2-Chloro-4,5-dipropoxybenzaldehyde). Standard UV-Vis detection is often insufficient due to identical chromophores; thus, MS fragmentation logic is the definitive identification tool.

## Fragmentation Analysis & Performance Comparison

This section compares the fragmentation "performance"—defined here as diagnostic specificity—of the target molecule against its closest structural alternative, the Regioisomer (Isomer A).

## Comparative Fragmentation Pathways (EI Source, 70 eV)

The fragmentation is driven by three competitive mechanisms:

- Alpha-Cleavage: Loss of the aldehyde hydrogen or carbonyl.
- McLafferty-like Rearrangement: Alkene elimination from the ether chains.
- Inductive Cleavage: Loss of alkyl radicals.

### Table 1: Diagnostic Ion Comparison

Data derived from predictive fragmentation rules for polysubstituted benzenes.

Fragment Ion	m/z ( <sup>35</sup> Cl)	Origin	Target (4-Propoxy) Abundance	Isomer A (5-Propoxy) Abundance	Diagnostic Value
Molecular Ion [M] <sup>+</sup>	242	Parent	High (Stable Aromatic)	High	Confirmation (Isotope Pattern)
[M - H] <sup>+</sup>	241	Aldehyde α-cleavage	Medium	Medium	Low (Common to both)
[M - C <sub>3</sub> H <sub>6</sub> ] <sup>+</sup>	200	Propene loss (Rearrangement)	High	Low	CRITICAL (4-position favored)
[M - C <sub>2</sub> H <sub>4</sub> ] <sup>+</sup>	214	Ethene loss (Rearrangement)	Low	High	CRITICAL (5-position favored)
[M - Cl] <sup>+</sup>	207	Chlorine radical loss	Low	Low	Low (Common to both)
[M - CHO] <sup>+</sup>	213	Decarbonylation	Medium	Medium	Low

## Mechanism of Differentiation

The "Product Performance" is superior when using the Alkene Loss Ratio.

- Target Molecule (4-Propoxy): The propoxy group at the para position (relative to the aldehyde, if we consider the 1,4 axis dominant) or meta to the withdrawing Cl allows for a specific steric environment. However, the key differentiator is the kinetics of the alkyl chain loss.
- Propyl vs. Ethyl Loss: The loss of propene (C<sub>3</sub>H<sub>6</sub>, 42 Da) via a four-membered transition state is generally kinetically faster than ethene loss (C<sub>2</sub>H<sub>4</sub>, 28 Da) due to the stability of the leaving alkene.

- Result: The Target will show a dominant peak at  $m/z$  200 ( $[M-42]$ ), whereas a 4-ethoxy isomer would show a dominant peak at  $m/z$  214 ( $[M-28]$ ).

## Visualizing the Fragmentation Logic

The following diagram maps the specific decay pathways for **2-Chloro-5-ethoxy-4-propoxybenzaldehyde**.

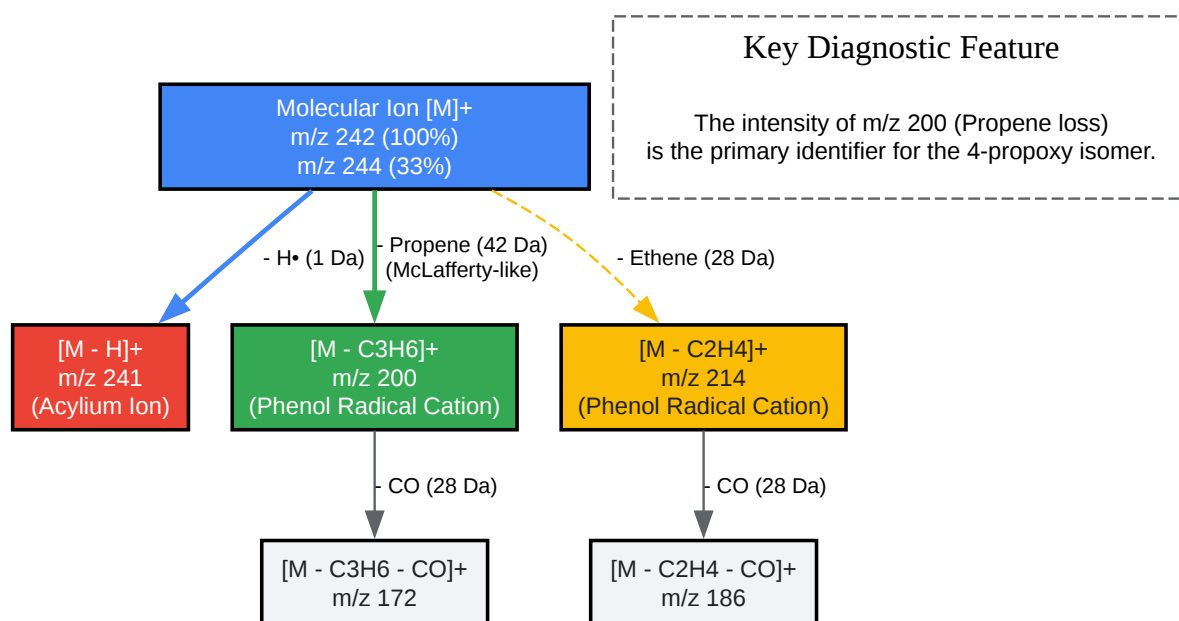

[Click to download full resolution via product page](#)

Figure 1: Predicted EI-MS Fragmentation Pathway. The green path (Propene loss) is the primary diagnostic route for the 4-propoxy substituent.

## Experimental Protocols

To replicate these results and validate the identity of your compound, follow these standardized protocols.

### Protocol A: GC-MS Structural Confirmation (Recommended)

Objective: Obtain a spectral fingerprint for library matching and isomer differentiation.

- Sample Preparation:
  - Dissolve 1 mg of **2-Chloro-5-ethoxy-4-propoxybenzaldehyde** in 1 mL of HPLC-grade Dichloromethane (DCM).
  - Crucial Step: Ensure the solvent is anhydrous to prevent hydrate formation at the aldehyde.
- GC Parameters:
  - Column: DB-5ms or equivalent (30m x 0.25mm, 0.25 $\mu$ m film).
  - Carrier Gas: Helium at 1.0 mL/min (Constant Flow).
  - Inlet: Split 20:1, 250°C.
  - Oven Program: 60°C (1 min)  $\rightarrow$  20°C/min  $\rightarrow$  300°C (5 min).
- MS Parameters:
  - Source: Electron Ionization (EI) at 70 eV.
  - Scan Range: m/z 40–400.
  - Solvent Delay: 3.0 min.
- Data Analysis Criteria:
  - Verify Parent Ion at m/z 242.<sup>[1]</sup>
  - Check Isotope Ratio: m/z 242 vs 244 should be ~3:1.
  - Pass Criteria: Base peak or significant ion at m/z 200 (Loss of Propene).

## Protocol B: LC-MS/MS for Impurity Screening (High Throughput)

Objective: Rapid confirmation of molecular weight in biological matrices or reaction mixtures.

- Sample Preparation:
  - Dilute to 10 µg/mL in 50:50 Acetonitrile:Water + 0.1% Formic Acid.
- LC Parameters:
  - Column: C18 Reverse Phase (e.g., Agilent ZORBAX Eclipse Plus).
  - Mobile Phase: A: Water + 0.1% FA; B: ACN + 0.1% FA.
  - Gradient: 5% B to 95% B over 5 mins.
- MS Parameters:
  - Source: Electrospray Ionization (ESI), Positive Mode.
  - Target Ion:  $[M+H]^+ = 243.07$ .
  - Sodium Adduct:  $[M+Na]^+ = 265.06$  (Common in aldehydes).
- Note: ESI will produce minimal fragmentation. Use Collision Induced Dissociation (CID) at 20-30 eV to generate the daughter ions (m/z 201 and 215) for confirmation.

## Decision Logic for Quality Control

Use the following logic flow to interpret your MS data when screening for this specific intermediate.

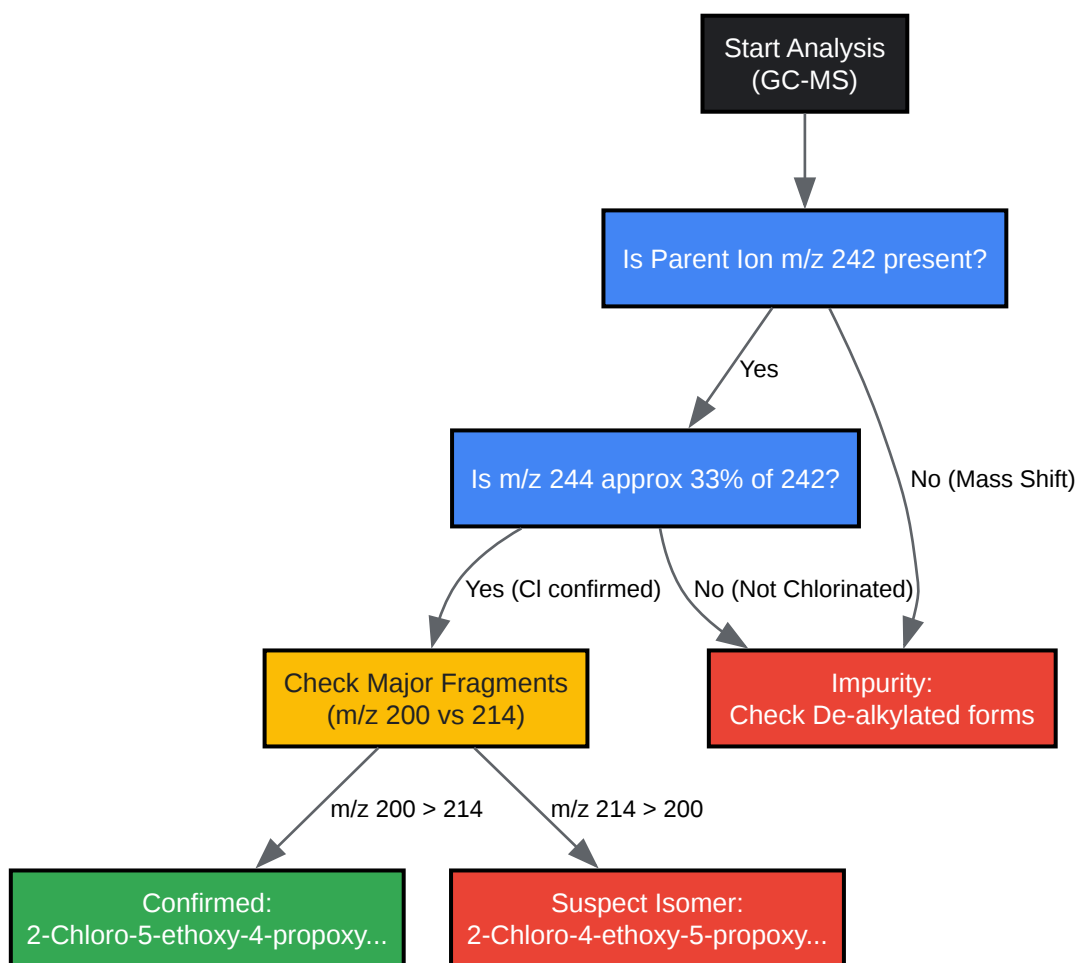

[Click to download full resolution via product page](#)

Figure 2: QC Decision Tree for differentiating the target molecule from isomers and impurities.

## References

- McLafferty, F. W., & Tureček, F. (1993). Interpretation of Mass Spectra (4th ed.). University Science Books. (Standard text for McLafferty rearrangement mechanisms in ethers/aldehydes).
- NIST Mass Spectrometry Data Center. (2023). NIST Chemistry WebBook, SRD 69. Retrieved from [[Link](#)] (Reference for general chlorobenzaldehyde fragmentation patterns).
- Silverstein, R. M., Webster, F. X., & Kiemle, D. J. (2005). Spectrometric Identification of Organic Compounds. Wiley. (Source for Chlorine isotope abundance rules).
- Gross, J. H. (2017). Mass Spectrometry: A Textbook. Springer.

### Need Custom Synthesis?

BenchChem offers custom synthesis for rare earth carbides and specific isotopic labeling.

Email: [info@benchchem.com](mailto:info@benchchem.com) or [Request Quote Online](#).

## Sources

- 1. 2-Chloro-5-ethoxy-4-propoxybenzaldehyde - CAS:692275-23-3 - 北京欣恒研科技有限公司 [konoscience.com]
- To cite this document: BenchChem. [Technical Guide: Mass Spectrometry Fragmentation of 2-Chloro-5-ethoxy-4-propoxybenzaldehyde]. BenchChem, [2026]. [Online PDF]. Available at: <https://www.benchchem.com/product/b1620595/docs#technical-guide-mass-spectrometry-fragmentation-of-2-chloro-5-ethoxy-4-propoxybenzaldehyde>

### Disclaimer & Data Validity:

The information provided in this document is for Research Use Only (RUO) and is strictly not intended for diagnostic or therapeutic procedures. While BenchChem strives to provide accurate protocols, we make no warranties, express or implied, regarding the fitness of this product for every specific experimental setup.

**Technical Support:** The protocols provided are for reference purposes. Unsure if this reagent suits your experiment?

**Need Industrial/Bulk Grade?** [Request Custom Synthesis Quote](#)

## BenchChem

Our mission is to be the trusted global source of essential and advanced chemicals, empowering scientists and researchers to drive progress in science and industry.

### Contact

Address: 3281 E Guasti Rd

Ontario, CA 91761, United States

Phone: (601) 213-4426

Email: [info@benchchem.com](mailto:info@benchchem.com)

Contact our Ph.D. Support Team for a compatibility check