

Cyclic Voltammetry of Substituted p-Benzoquinones: A Comparative Technical Guide

Author: BenchChem Technical Support Team. **Date:** April 2026

Compound of Interest

Compound Name:	2,5-Dichloro-3,6-bis(diethylamino)- <i>p</i> -benzoquinone
CAS No.:	23019-38-7
Cat. No.:	B1619290

[Get Quote](#)

Executive Summary

This guide provides an in-depth technical comparison of substituted *p*-benzoquinones using cyclic voltammetry (CV). Designed for researchers in electrochemistry and drug discovery, it moves beyond basic textbook definitions to address the practical realities of redox tuning.

p-Benzoquinone (PBQ) serves as the structural scaffold for ubiquinone (Coenzyme Q10) and various chemotherapeutic agents. By substituting the quinone ring with electron-withdrawing groups (EWGs) or electron-donating groups (EDGs), researchers can precisely modulate the lowest unoccupied molecular orbital (LUMO) energy, thereby dictating the thermodynamic ease of reduction. This guide quantifies these shifts and provides a validated protocol for reproducing these results in aprotic media.

Fundamental Redox Mechanism

In aqueous media, quinone reduction is often a single 2-electron, 2-proton step (

) merging into one peak due to rapid protonation. However, to accurately assess electronic substituent effects without the interference of pH-dependent equilibria, aprotic solvents (e.g., Acetonitrile, DMF) are required.

In dry aprotic conditions, the reduction occurs in two distinct one-electron steps:

- First Reduction (): Formation of the radical anion (Semiquinone,).[1][2]
- Second Reduction (): Formation of the dianion ().[3]

Mechanism Diagram

The following diagram illustrates the sequential reduction pathway and the critical influence of solvent purity (proton sources).

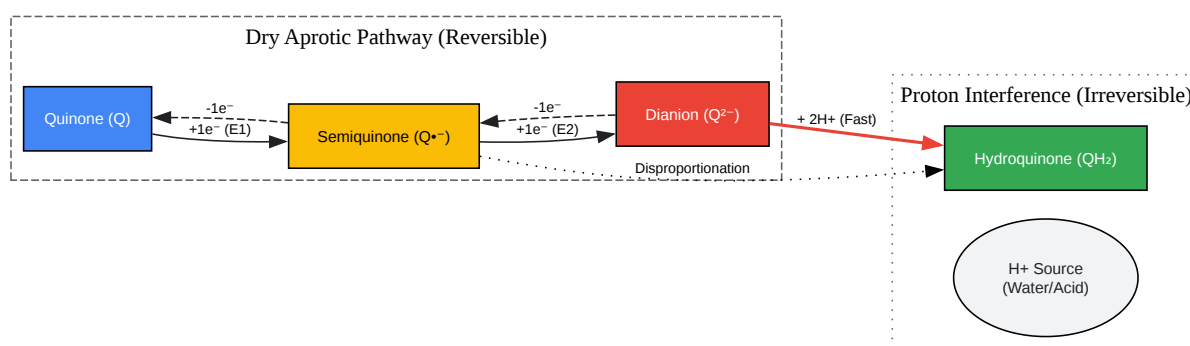

[Click to download full resolution via product page](#)

Caption: Stepwise reduction of quinones in aprotic media. Proton sources (water impurities) trigger rapid protonation, merging waves and causing irreversibility.

Validated Experimental Protocol

Objective: To resolve two distinct reversible waves for p-benzoquinone derivatives. Common

Pitfall: The presence of trace water collapses the two waves into one broad peak.

Reagents & Equipment[5][6]

- Solvent: Acetonitrile (MeCN), anhydrous (99.8%), stored over activated 3Å molecular sieves.
- Electrolyte: Tetrabutylammonium hexafluorophosphate (), 0.1 M.[1]
 - Note: Avoid Lithium salts () for kinetic studies; coordinates with the radical anion, altering potentials and occasionally causing electrode passivation films [1].
- Working Electrode: Glassy Carbon (3 mm diameter).[4][5]
- Reference Electrode: (10 mM in MeCN) or pseudo-reference (Pt wire) with internal Ferrocene standard.

Step-by-Step Workflow

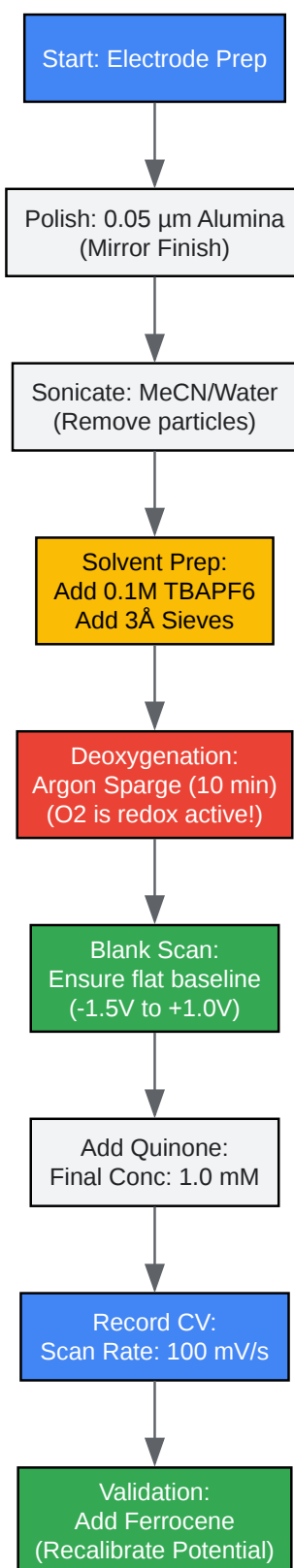

[Click to download full resolution via product page](#)

Caption: Operational workflow for non-aqueous CV.[4] Deoxygenation and internal standardization (Ferrocene) are critical control points.

Comparative Performance Analysis

The electronic nature of substituents on the quinone ring dictates the reduction potential. This follows a Hammett Correlation:

- Electron-Withdrawing Groups (EWGs): Stabilize the LUMO, shifting positive (Anodic shift). The molecule becomes a stronger oxidant.
- Electron-Donating Groups (EDGs): Destabilize the LUMO, shifting negative (Cathodic shift). The molecule is harder to reduce.

Data Table: Reduction Potentials in Acetonitrile

Values are referenced to the Saturated Calomel Electrode (SCE). To convert to , subtract -0.38 V.

Compound	Structure	Substituent Type	()	()	(vs PBQ)	Reactivity Insight
DDQ	2,3-Dichloro-5,6-dicyano	Strong EWG	+0.51 V	-0.30 V	+1.02 V	Super-Oxidant. Used for dehydrogenation in synthesis.
Chloranil	Tetrachloro	Moderate EWG	+0.01 V	-0.71 V	+0.52 V	Strong oxidant; stable radical anion.
p-Benzoquinone	Unsubstituted	Reference	-0.51 V	-1.14 V	0.00 V	Baseline biological mimic.
Duroquinone	Tetramethyl	Moderate EDG	-0.84 V	-1.45 V	-0.33 V	Mimics Plastoquinone; difficult to reduce.

Data synthesized from comparative studies [2][3]. Note: Absolute values may vary by ± 50 mV depending on the specific reference electrode junction, but the relative shifts (

) are robust.

Technical Interpretation[1][9][10]

- The "Chloranil Shift": Adding four chlorines shifts the first reduction potential by over +500 mV compared to PBQ. This massive anodic shift explains why Chloranil is a viable oxidant for aromatizing organic substrates, whereas PBQ is often too weak [2].
- The "Duroquinone Effect": The four methyl groups donate electron density via hyperconjugation, raising the energy of the LUMO. This makes Duroquinone significantly

harder to reduce (-0.84 V). In biological systems, this tuning prevents the molecule from stealing electrons indiscriminately, ensuring specificity in the electron transport chain [3].

- Peak Separation (

): For a truly reversible Nernstian system, the separation between the anodic and cathodic peak of a single wave (

) should be ~ 59 mV/n.

- Self-Validation Check: If your

at 100 mV/s, your system likely suffers from uncompensated resistance (

drop). Action: Check electrode polishing or increase electrolyte concentration.

Troubleshooting & Expert Insights

The "Merging Waves" Phenomenon

Observation: You see only one broad wave instead of two distinct waves for Chloranil or PBQ.

Root Cause: Hydrogen Bonding. Explanation: The dianion (

) is extremely basic. If trace water or alcohols are present, they hydrogen bond to the dianion or protonate it. This stabilizes the second reduction product, shifting

positively until it overlaps with

. Solution: Add activated alumina to the cell or switch to a "Super-Dry" solvent protocol.

Electrode Passivation

Observation: Peak currents decrease with subsequent scans. Root Cause: Polymerization or adsorption. Explanation: Radical anions of simple quinones (like PBQ) can be unstable and polymerize on the electrode surface, especially in the presence of Lithium cations (

) [1]. Solution: Use bulky cations like Tetrabutylammonium (

) and polish the electrode between scans.

References

- Rueda-García, D., Dubal, D. P., Hugenin, F., & Gómez-Romero, P. (2025). Hurdles to organic quinone flow cells: Electrode passivation by quinone reduction in acetonitrile Li electrolytes. ResearchGate.
- Connell, G. E., & Ingram, J. (2016). Quinone 1 e⁻ and 2 e⁻/2 H⁺ Reduction Potentials: Identification and Analysis of Deviations from Systematic Scaling Relationships. Journal of the American Chemical Society.
- Prince, R., & Patrick, B. (2024). First and Second Reductions in an Aprotic Solvent: Comparing Computational and Experimental One-Electron Reduction Potentials for 345 Quinones. Journal of Chemical Information and Modeling.
- Nematollahi, D., & Rafiee, M. (2017). Electrochemical Studies of Benzoquinone and its Derivatives. MDPI Molecules.

Need Custom Synthesis?

BenchChem offers custom synthesis for rare earth carbides and specific isotopic labeling.

Email: info@benchchem.com or [Request Quote Online](#).

Sources

- [1. mdpi.com](https://www.mdpi.com) [[mdpi.com](https://www.mdpi.com)]
- [2. First and Second Reductions in an Aprotic Solvent: Comparing Computational and Experimental One-Electron Reduction Potentials for 345 Quinones - PMC](https://pubmed.ncbi.nlm.nih.gov/34512345/) [[pmc.ncbi.nlm.nih.gov](https://pubmed.ncbi.nlm.nih.gov/34512345/)]
- [3. pubs.acs.org](https://pubs.acs.org) [pubs.acs.org]
- [4. research-explorer.ista.ac.at](https://research-explorer.ista.ac.at) [research-explorer.ista.ac.at]
- [5. pubs.acs.org](https://pubs.acs.org) [pubs.acs.org]
- To cite this document: BenchChem. [Cyclic Voltammetry of Substituted p-Benzoquinones: A Comparative Technical Guide]. BenchChem, [2026]. [Online PDF]. Available at: [<https://www.benchchem.com/product/b1619290/docs#cyclic-voltammetry-of-substituted-p-benzoquinones-a-comparative-technical-guide>]

Disclaimer & Data Validity:

The information provided in this document is for Research Use Only (RUO) and is strictly not intended for diagnostic or therapeutic procedures. While BenchChem strives to provide accurate protocols, we make no warranties, express or implied, regarding the fitness of this product for every specific experimental setup.

Technical Support: The protocols provided are for reference purposes. Unsure if this reagent suits your experiment?

Need Industrial/Bulk Grade? [Request Custom Synthesis Quote](#)

BenchChem

Our mission is to be the trusted global source of essential and advanced chemicals, empowering scientists and researchers to drive progress in science and industry.

Contact

Address: 3281 E Guasti Rd
Ontario, CA 91761, United States
Phone: (601) 213-4426
Email: info@benchchem.com

[Contact our Ph.D. Support Team for a compatibility check](#)