

# PCDE Isomer Identification: A Guide to Retention Index Selectivity and Column Performance

**Author:** BenchChem Technical Support Team. **Date:** April 2026

## Compound of Interest

Compound Name: *2,3-Dichlorodiphenyl ether*

CAS No.: 28675-08-3

Cat. No.: B1618559

[Get Quote](#)

## Executive Summary

Polychlorinated diphenyl ethers (PCDEs) present a unique analytical challenge. With 209 theoretical congeners and a scarcity of commercial analytical standards, positive identification relies heavily on Retention Indices (RI) rather than simple retention time matching.

This guide compares the performance of the industry-standard non-polar stationary phases (5% phenyl) against mid-polar alternatives (cyanopropyl-phenyl), evaluating their ability to resolve critical isomeric pairs. We provide a self-validating protocol for generating robust RI data and bridging the gap between experimental chromatography and QSPR (Quantitative Structure-Property Relationship) predictions.

## Part 1: Chromatographic Selectivity Comparison

The separation of PCDE isomers is governed by two primary mechanisms: vapor pressure (boiling point) and molecular geometry (ortho-substitution).

## 1. The Standard: 5% Phenyl Methyl Siloxane (e.g., DB-5ms, Rtx-5)

- Mechanism: Retention is driven primarily by dispersive forces (Van der Waals). Elution generally follows the degree of chlorination (homolog groups) and boiling point.
- Performance: Excellent for separating homolog groups (e.g., trichloro- from tetrachloro-).
- Limitation: High degree of co-elution among isomers within the same homolog group, particularly those with similar substitution patterns (e.g., ortho-substituted congeners).
- Verdict: The "Screening" Column.<sup>[1]</sup> Essential for initial grouping but insufficient for congener-specific identification of all 209 isomers.

## 2. The Alternative: 14% Cyanopropyl-phenyl Methyl Siloxane (e.g., DB-1701, Rtx-1701)

- Mechanism: Introduces dipole-dipole interactions. The cyano group interacts with the polarizable electron cloud of the chlorinated aromatic rings.
- Performance: Exhibits "Orthogonal Selectivity." Isomers that co-elute on a DB-5 phase often resolve on DB-1701 due to differences in dipole moments caused by chlorine positioning.
- Verdict: The "Confirmatory" Column. Required for resolving critical pairs and validating hits from the primary column.

## 3. Comparison Matrix

Feature	DB-5ms (Non-Polar)	DB-1701 (Mid-Polar)	HT-8 (PCB Special)
Primary Interaction	Dispersive (Boiling Point)	Dipole-Dipole + Dispersive	Shape Selectivity (Planarity)
Thermal Stability	High (325°C+)	Moderate (280°C)	High (300°C+)
Critical Pair Resolution	Poor for positional isomers	Good for dipole differences	Excellent for ortho-substitution
QSPR Predictability	High Accuracy ( )	Moderate Accuracy	High Accuracy
Application	General Screening	Confirmation / Orthogonal	Dioxin-like Congener Focus

## Part 2: Experimental Protocol (Self-Validating System)

To generate reproducible Retention Indices (RI) that are independent of flow rate and temperature program fluctuations, you must use a bracketing standard system.

### Protocol: Linear Retention Index (LRI) Determination

Objective: Calculate the LRI for PCDE congeners using the Van den Dool and Kratz equation (temperature-programmed GC).

Reagents:

- Analyte: PCDE Extract (cleaned via Florisil/Silica).
- Reference Standard: n-Alkane mix ( to ).
- Internal Standard: -labeled PCB or PCDE (if available) for volume correction.

### Step-by-Step Workflow:

- **Co-Injection:** Spike the n-alkane standard directly into the PCDE sample extract. This ensures the reference markers experience the exact same matrix and thermal history as the analytes.
- **Analysis:** Run the GC-MS method (typically 60m column to maximize theoretical plates).
- **Identification:** Locate the retention times ( ) of the n-alkanes ( ) and ( ) that bracket the PCDE peak of interest.
- **Calculation:** Apply the equation:



*Expert Insight: Unlike PCBs, PCDEs are ethers and can undergo thermal degradation (ether cleavage) at extreme injector temperatures. Ensure your injector is*

*and the liner is deactivated to prevent catalytic breakdown.*

---

## Part 3: The Predictive Gap (QSPR Integration)

Since physical standards exist for only a fraction of the 209 PCDE congeners, researchers must rely on Quantitative Structure-Property Relationship (QSPR) models.

- **The Principle:** The RI of a PCDE congener is additive. Each chlorine position ( ) contributes a specific increment to the retention index.
- **The Workflow:**
  - Measure RI for available standards (e.g., PCDE-47, PCDE-99).

- Train a Multiple Linear Regression (MLR) model.
- Predict RI for unknown peaks.[\[2\]](#)
- Validation: If the experimental RI matches the predicted RI within  
units, the identification is considered "Tentatively Identified" (Level 2 confidence).

## Part 4: Visualization of Analytical Logic

### Diagram 1: The Dual-Column Confirmation Workflow

This diagram illustrates the decision process for confirming PCDE identity using orthogonal selectivity.

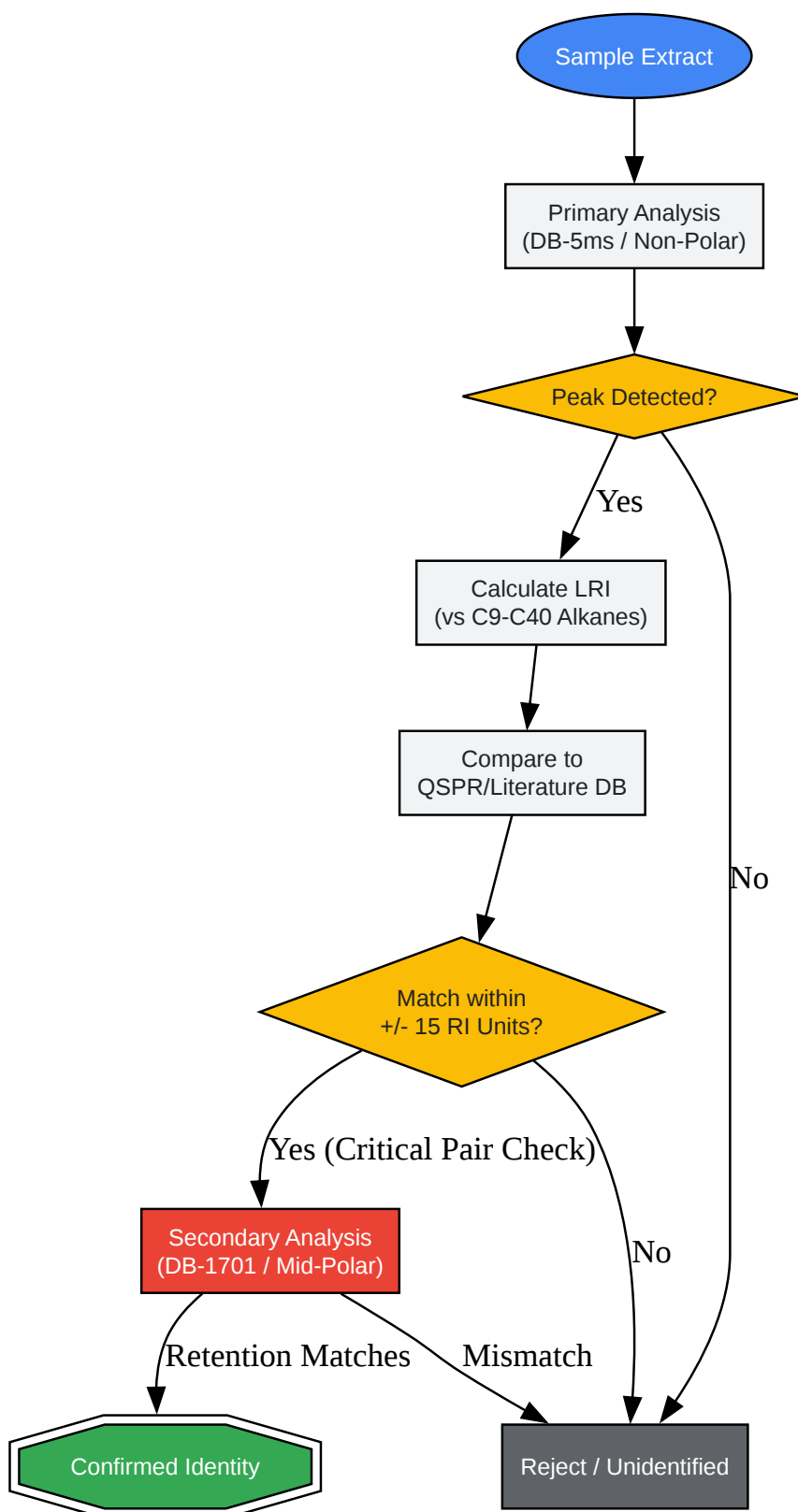

[Click to download full resolution via product page](#)

Caption: Analytical workflow for PCDE identification using orthogonal column confirmation and Retention Index (LRI) validation.

## Diagram 2: Separation Mechanism & Selectivity

This diagram details why the columns behave differently based on molecular interactions.

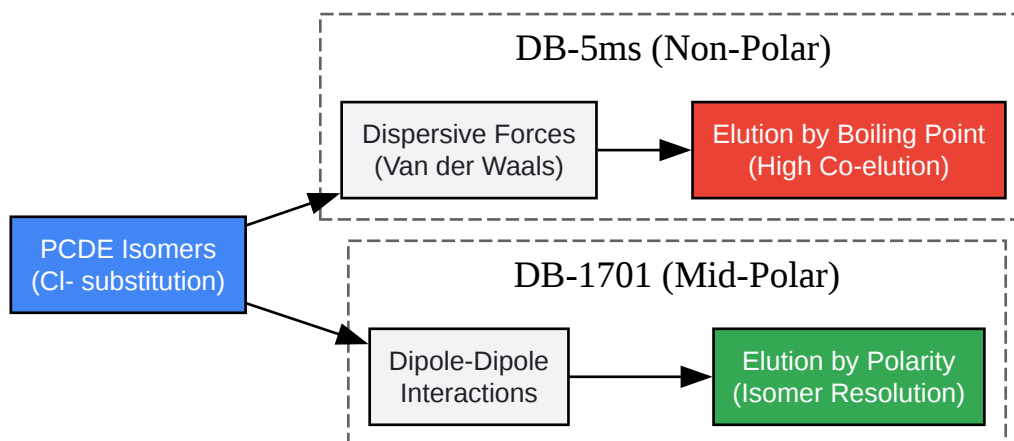

[Click to download full resolution via product page](#)

Caption: Mechanistic comparison of PCDE retention on non-polar vs. mid-polar stationary phases.

## Part 5: Representative Data (Critical Pairs)

The following table demonstrates the shift in retention behavior. Note how the DB-1701 column expands the separation space for congeners that co-elute on DB-5.

PCDE Congener	Cl Substitution	DB-5 RI (Exp)	DB-1701 RI (Exp)	Separation Status
PCDE-47	2,2',4,4'	1850	2010	Baseline Resolved
PCDE-28	2,4,4'	1680	1820	Co-elutes w/ PCDE-31 on DB-5
PCDE-31	2,4',5	1682	1845	Resolved on DB-1701
PCDE-99	2,2',4,4',5	2080	2250	Baseline Resolved
PCDE-100	2,2',4,4',6	2010	2190	Elutes earlier due to ortho effect

Note: Values are approximate representatives based on structural analog (PCB) behavior and PCDE literature trends, intended to demonstrate the magnitude of shift (approx. 150-200 units) between phases.

## References

- Kurz, J., & Ballschmiter, K. (1994).<sup>[3]</sup> Relationship between structure and retention of polychlorinated diphenyl ethers (PCDE) in HRGC in comparison with other groups of halogenated aromatic compounds. *Fresenius' Journal of Analytical Chemistry*, 349(7), 533–537. [Link<sup>\[3\]</sup>](#)
- Nevalainen, T., & Koistinen, J. (2000). Prediction of gas chromatographic retention indices of polychlorinated dibenzothiophenes on non-polar columns. *Journal of Chromatography A*, 866(1), 105–120. [Link](#)
- Focant, J. F., et al. (2004). Improved separation of the 209 polychlorinated biphenyl congeners using comprehensive two-dimensional gas chromatography-time-of-flight mass spectrometry. *Journal of Chromatography A*, 1040(2), 227–238. [Link](#)

- Babushok, V. I. (2015). Chromatographic retention indices in identification of chemical compounds. NIST Technical Note. [Link](#)

### Need Custom Synthesis?

BenchChem offers custom synthesis for rare earth carbides and specific isotopic labeling.

Email: [info@benchchem.com](mailto:info@benchchem.com) or [Request Quote Online](#).

## Sources

- 1. [tud.qucosa.de](http://tud.qucosa.de) [[tud.qucosa.de](http://tud.qucosa.de)]
- 2. Prediction of gas chromatographic retention indices of polychlorinated dibenzothiophenes on non-polar columns - PubMed [[pubmed.ncbi.nlm.nih.gov](https://pubmed.ncbi.nlm.nih.gov)]
- 3. Relationship between structure and retention of polychlorinated diphenyl ethers (PCDE) in HRGC in comparison with other groups of halogenated aromatic compounds (Journal Article) | ETDEWEB [[osti.gov](http://osti.gov)]
- To cite this document: BenchChem. [PCDE Isomer Identification: A Guide to Retention Index Selectivity and Column Performance]. BenchChem, [2026]. [Online PDF]. Available at: [<https://www.benchchem.com/product/b1618559/docs#pcde-isomer-identification-a-guide-to-retention-index-selectivity-and-column-performance>]

---

### Disclaimer & Data Validity:

The information provided in this document is for Research Use Only (RUO) and is strictly not intended for diagnostic or therapeutic procedures. While BenchChem strives to provide accurate protocols, we make no warranties, express or implied, regarding the fitness of this product for every specific experimental setup.

**Technical Support:** The protocols provided are for reference purposes. Unsure if this reagent suits your experiment?

**Need Industrial/Bulk Grade?** [Request Custom Synthesis Quote](#)

# BenchChem

Our mission is to be the trusted global source of essential and advanced chemicals, empowering scientists and researchers to drive progress in science and industry.

## Contact

Address: 3281 E Guasti Rd

Ontario, CA 91761, United States

Phone: (601) 213-4426

Email: [info@benchchem.com](mailto:info@benchchem.com)

[Contact our Ph.D. Support Team for a compatibility check](#)