

Application Notes and Protocol: Sharpless Asymmetric Dihydroxylation of 2-Chlorostyrene

Author: BenchChem Technical Support Team. **Date:** May 2026

Compound of Interest

Compound Name:	(R)-1-(2- CHLOROPHENYL)ETHANE-1,2- DIOL
CAS No.:	59365-60-5
Cat. No.:	B1617189

[Get Quote](#)

Introduction: The Strategic Importance of Chiral Diols

The Sharpless Asymmetric Dihydroxylation (SAD) stands as a landmark achievement in modern organic synthesis, providing a reliable and highly enantioselective method for converting prochiral alkenes into vicinal diols.^{[1][2]} This transformation, for which K. Barry Sharpless was a co-recipient of the 2001 Nobel Prize in Chemistry, is indispensable due to the prevalence of the chiral 1,2-diol motif in a vast array of pharmaceuticals, natural products, and advanced materials.^{[1][3]} The power of the SAD process lies in its use of a catalytic amount of a toxic and expensive osmium reagent, which is continuously regenerated in a catalytic cycle.^{[3][4]}

This guide provides a detailed protocol and in-depth technical discussion for the asymmetric dihydroxylation of 2-chlorostyrene. This substrate is of particular interest as the resulting chiral diol, (1-chloro-2-phenyl)ethane-1,2-diol, is a versatile building block for synthesizing complex molecules where stereochemistry is critical. The protocol leverages the commercially available

AD-mix formulations, which contain all necessary reagents in pre-measured quantities, simplifying the experimental setup and ensuring reproducibility.[2][5][6]

The Catalytic Heart of the Reaction: Mechanism and Enantioselectivity

The SAD reaction operates through a sophisticated, ligand-accelerated catalytic cycle. Understanding this mechanism is paramount for troubleshooting and optimizing the reaction for different substrates.

Core Components of the AD-mix:[5][7]

- Osmium Source: Potassium osmate ($K_2OsO_2(OH)_4$) serves as the precursor to the active OsO_4 catalyst.[5][8]
- Chiral Ligand: Dimeric cinchona alkaloid derivatives, $(DHQ)_2PHAL$ in AD-mix- α and $(DHQD)_2PHAL$ in AD-mix- β , create a chiral environment around the osmium center.[1][5]
- Stoichiometric Oxidant: Potassium ferricyanide ($K_3Fe(CN)_6$) is the workhorse that regenerates the Os(VIII) species from the reduced Os(VI) state, allowing the use of catalytic osmium.[1][7]
- Base: Potassium carbonate (K_2CO_3) maintains the slightly alkaline pH required for optimal reaction rates and catalyst stability.[5][7]

The reaction proceeds via an initial [3+2]-cycloaddition of the alkene to the chiral osmium tetroxide-ligand complex.[1][2][3] This forms a cyclic osmate ester intermediate. Subsequent hydrolysis releases the desired chiral diol and the reduced osmium(VI) species. The potassium ferricyanide then re-oxidizes the osmium back to its active Os(VIII) state, completing the primary catalytic cycle.[1]

A potential secondary pathway can diminish enantioselectivity. If the osmate ester is re-oxidized before hydrolysis, a non-selective dihydroxylation can occur.[1] This is often suppressed by using a sufficient concentration of the chiral ligand and avoiding excessively high substrate concentrations.[1][2]

Fig 1. Catalytic cycle of the Sharpless Asymmetric Dihydroxylation.

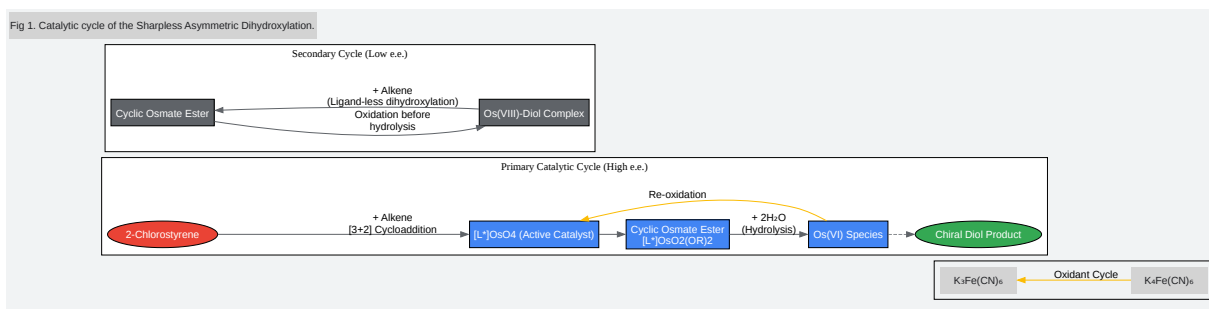

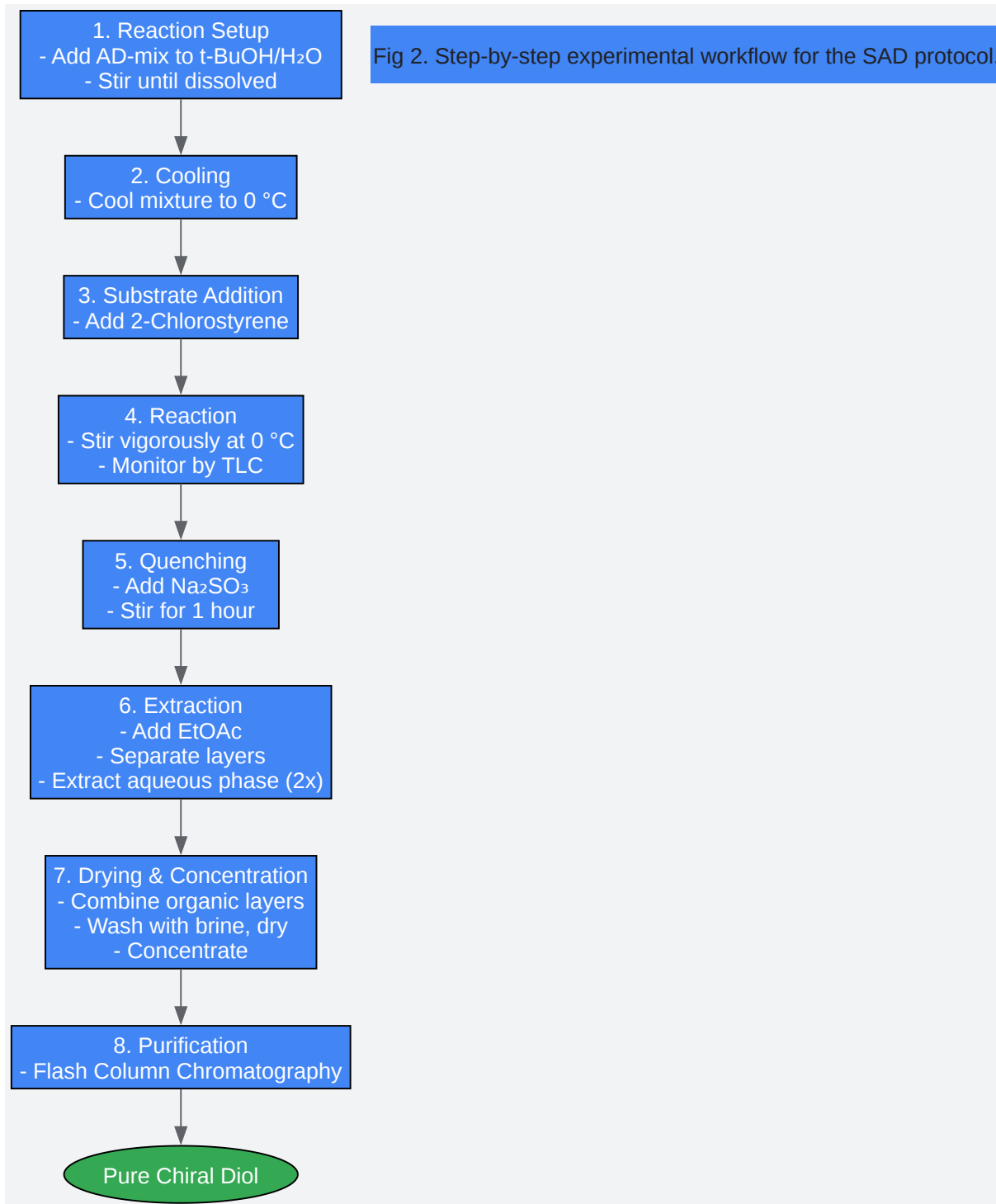

[Click to download full resolution via product page](#)

Need Custom Synthesis?

BenchChem offers custom synthesis for rare earth carbides and specific isotopic labeling.

Email: info@benchchem.com or [Request Quote Online](#).

Sources

- [1. Sharpless asymmetric dihydroxylation - Wikipedia \[en.wikipedia.org\]](#)
- [2. Sharpless Dihydroxylation \(Bishydroxylation\) \[organic-chemistry.org\]](#)
- [3. rroj.com \[rroj.com\]](#)
- [4. encyclopedia.pub \[encyclopedia.pub\]](#)
- [5. pdf.benchchem.com \[pdf.benchchem.com\]](#)
- [6. AD-mix - Wikipedia \[en.wikipedia.org\]](#)
- [7. grokipedia.com \[grokipedia.com\]](#)
- [8. Potassium osmate - Wikipedia \[en.wikipedia.org\]](#)
- To cite this document: BenchChem. [Application Notes and Protocol: Sharpless Asymmetric Dihydroxylation of 2-Chlorostyrene]. BenchChem, [2026]. [Online PDF]. Available at: [\[https://www.benchchem.com/product/b1617189/docs#application-notes-and-protocol-sharpless-asymmetric-dihydroxylation-of-2-chlorostyrene\]](https://www.benchchem.com/product/b1617189/docs#application-notes-and-protocol-sharpless-asymmetric-dihydroxylation-of-2-chlorostyrene)

Disclaimer & Data Validity:

The information provided in this document is for Research Use Only (RUO) and is strictly not intended for diagnostic or therapeutic procedures. While BenchChem strives to provide accurate protocols, we make no warranties, express or implied, regarding the fitness of this product for every specific experimental setup.

Technical Support: The protocols provided are for reference purposes. Unsure if this reagent suits your experiment?

Need Industrial/Bulk Grade? [Request Custom Synthesis Quote](#)

BenchChem

Our mission is to be the trusted global source of essential and advanced chemicals, empowering scientists and researchers to drive progress in science and industry.

Contact

Address: 3281 E Guasti Rd

Ontario, CA 91761, United States

Phone: (601) 213-4426

Email: info@benchchem.com

[Contact our Ph.D. Support Team for a compatibility check](#)