

# A Comparative Guide to Penicillamine Mixed Disulfides for Drug Development Professionals

**Author:** BenchChem Technical Support Team. **Date:** May 2026

## Compound of Interest

Compound Name: *Penicillamine disulfide*

CAS No.: 312-10-7

Cat. No.: B1617911

[Get Quote](#)

This guide provides an in-depth comparative analysis of penicillamine mixed disulfides, tailored for researchers, scientists, and drug development professionals. We will move beyond surface-level descriptions to explore the causal mechanisms behind their formation, their distinct biological significance, and the rigorous experimental protocols required for their accurate characterization. This document is designed to serve as a foundational resource, blending established scientific principles with field-proven insights to support advanced research and development.

## The Central Role of the Thiol Group: From Therapy to Toxicity

Penicillamine is a trifunctional amino acid, structurally similar to cysteine, but distinguished by geminal dimethyl groups alpha to its thiol (-SH) moiety.<sup>[1]</sup> While it is a metabolite of penicillin, it possesses no antibiotic properties.<sup>[1][2]</sup> Its therapeutic utility as a chelating agent in Wilson's disease and as a disease-modifying antirheumatic drug (DMARD) stems directly from the reactivity of this thiol group.<sup>[1][3][4]</sup>

However, this same reactivity is a double-edged sword. In biological systems, penicillamine readily participates in thiol-disulfide exchange reactions with endogenous molecules like cystine and glutathione, or with cysteine residues in proteins. This process results in the formation of various mixed disulfides, which are not merely inactive metabolites but are often key mediators of both the drug's therapeutic action and its significant adverse effect profile.[5] [6]

The fundamental reaction involves the nucleophilic attack of penicillamine's thiolate anion ( $R-S^-$ ) on a disulfide bond ( $R'-S-S-R'$ ), cleaving it and forming a new, mixed disulfide ( $R-S-S-R'$ ).

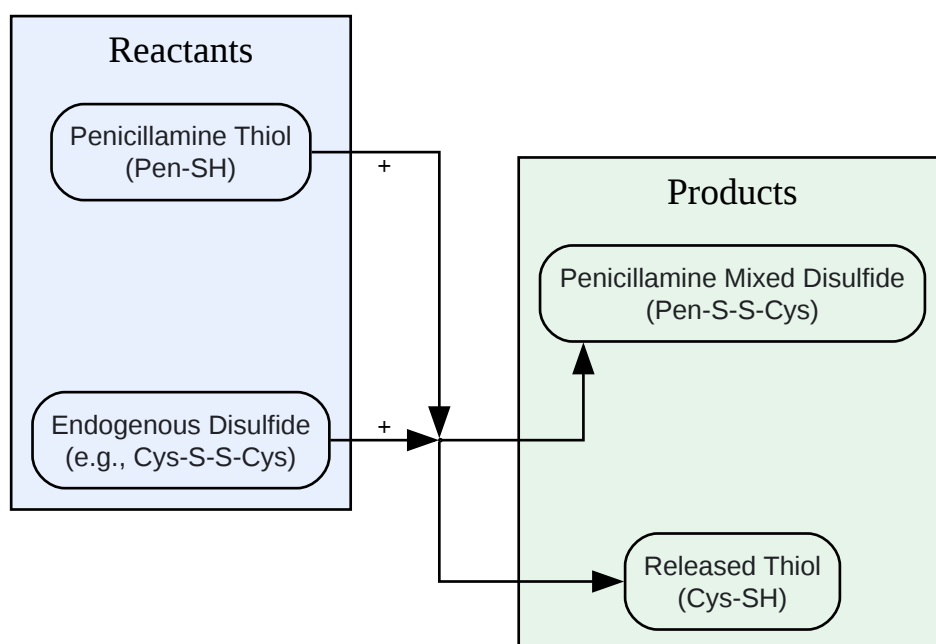

[Click to download full resolution via product page](#)

Figure 1: General mechanism of penicillamine mixed disulfide formation.

## A Comparative Analysis of Major Penicillamine Disulfides

The specific disulfide formed dictates the subsequent biological outcome. Understanding their distinct characteristics is therefore critical for any mechanistic study.

Disulfide Species	Context of Formation	Key Biological & Clinical Significance
Penicillamine-Cysteine	Formed via disulfide interchange with cysteine.[3][7][8]	Therapeutic: This mixed disulfide is significantly more water-soluble than cystine.[3][9] This property is the cornerstone of penicillamine's use in cystinuria, as it prevents the formation of cystine kidney stones by facilitating its excretion.[1][3]
Penicillamine Disulfide	The symmetrical disulfide formed by the oxidation of two penicillamine molecules.	Represents a major metabolite found in plasma and urine.[6] Its reduction back to the active thiol form is less efficient compared to other drug disulfides like captopril disulfide, which may contribute to its accumulation.[10]
Penicillamine-Protein	Formed with cysteine residues on plasma proteins, primarily albumin.[2][5]	Pharmacokinetic: Over 80% of penicillamine in plasma becomes protein-bound.[5][6] This binding creates a "deep compartment," leading to a slow elimination phase and a long biological half-life, which can explain persistent effects (both therapeutic and adverse) even after discontinuation.[6] Toxicological: These drug-protein adducts can be recognized as foreign by the immune system, potentially triggering severe autoimmune reactions like drug-induced

lupus, myasthenia gravis, and pemphigus.[9][11]

---

## Experimental Design: Protocols for Accurate Characterization

The analysis of penicillamine and its disulfides is notoriously challenging due to the instability of the thiol group, the presence of endogenous thiols, and the various forms the drug takes in vivo.[6] Methodologies must be designed to preserve the in vivo state of the analytes or to quantitatively convert them to a single, stable form for measurement.

### The Critical Importance of Sample Preparation

**Causality:** The primary goal of sample preparation is to prevent artefactual oxidation or disulfide exchange post-collection. Free thiol groups are highly susceptible to oxidation, which would artificially inflate the measured disulfide concentrations. Therefore, immediate stabilization is mandatory.

#### Protocol: Differential Thiol and Disulfide Analysis

- **Collection:** Collect blood samples into tubes containing an anticoagulant (e.g., EDTA). Place on ice immediately.
- **Immediate Stabilization:** Within 1 minute of collection, divide the sample.
  - **For Free Thiol Analysis:** Add a solution of a thiol-blocking agent, such as N-ethylmaleimide (NEM), to the sample. NEM forms a stable, irreversible covalent bond with free thiol groups, preventing their oxidation.
  - **For Total Thiol/Disulfide Analysis:** Add a solution of a strong reducing agent, such as dithiothreitol (DTT), to a separate aliquot. DTT will reduce all disulfide bonds (mixed and symmetrical) to their constituent free thiols.
- **Protein Precipitation:** Add an acid (e.g., perchloric acid or trichloroacetic acid) to precipitate proteins. This releases any protein-bound penicillamine.

- Centrifugation: Centrifuge the samples at high speed (e.g., 10,000 x g for 10 minutes at 4°C) to pellet the precipitated proteins.
- Supernatant Collection: Carefully collect the supernatant for analysis. The concentration of mixed disulfides can be calculated by subtracting the free thiol concentration from the total concentration after reduction.

Figure 2: Sample preparation workflow for differential analysis.

## Recommended Analytical Technique: HPLC with Dual-Electrode Electrochemical Detection (HPLC-ECD)

Causality: HPLC-ECD is the preferred method due to its exceptional sensitivity and, crucially, its ability to differentiate between reduced thiols and oxidized disulfides within a single chromatographic run.<sup>[12][13][14]</sup> This is achieved using a dual-electrode electrochemical cell.

System Logic:

- Upstream Electrode (Generator): Set to a high reducing potential. As the mobile phase flows past, any disulfide bonds in the analytes are reduced (cleaved) into their corresponding thiols.
- Downstream Electrode (Detector): Set to an oxidizing potential. It detects and quantifies all thiols present: both those that were originally in the sample and those newly generated at the upstream electrode. By comparing the signal with and without the upstream electrode active, one can quantify the disulfide forms directly.

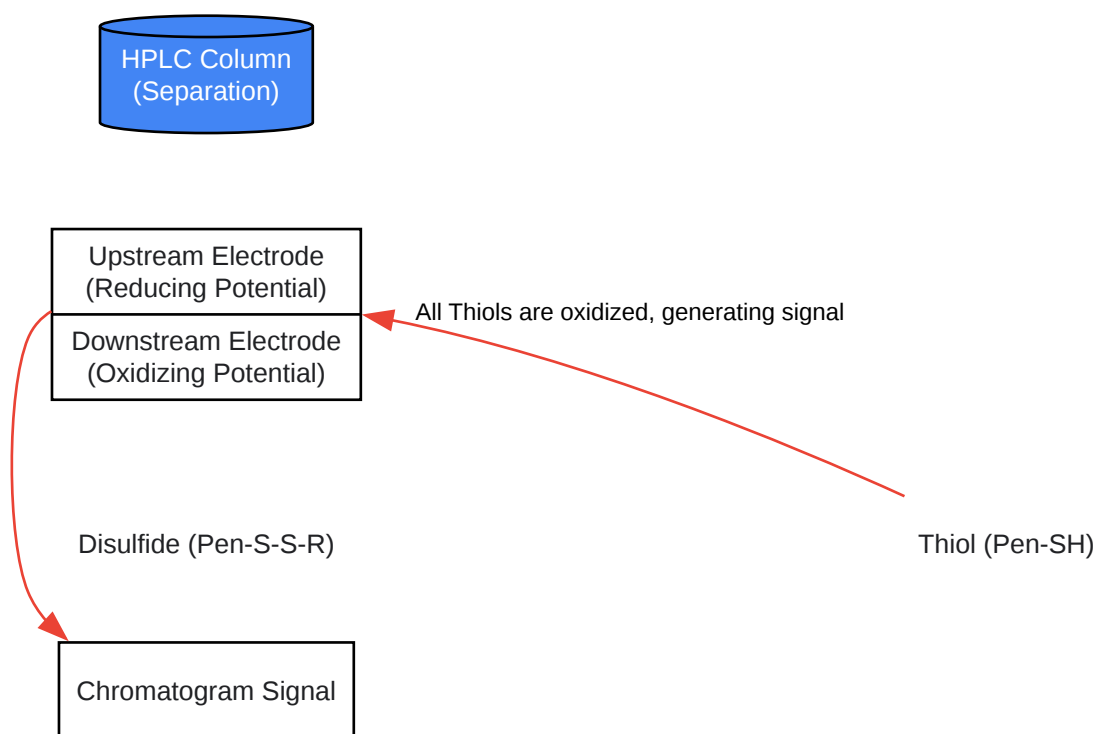

[Click to download full resolution via product page](#)

Figure 3: Logic of the dual-electrode electrochemical detector.

#### Experimental Protocol Outline:

- Instrumentation: HPLC system with a dual-electrode electrochemical detector (e.g., gold/mercury amalgam electrodes).[12][13]
- Column: C18 reversed-phase column (e.g., 4.6 x 250 mm, 5  $\mu$ m).
- Mobile Phase: Isocratic or gradient elution using a filtered and degassed mobile phase, typically an aqueous phosphate buffer with an organic modifier like methanol or acetonitrile and an ion-pairing agent to improve retention.
- Flow Rate: Typically 0.8-1.2 mL/min.
- Detector Settings:
  - Upstream (Guard) Cell Potential: Set to a reducing potential sufficient to cleave disulfides (e.g., -1.0 V).

- Downstream (Analytical) Cell Potential: Set to an oxidizing potential to detect thiols (e.g., +0.15 V).
- Calibration: Prepare calibration standards of penicillamine, **penicillamine disulfide**, and synthesized penicillamine-cysteine mixed disulfide in a matrix matching the prepared samples.
- Analysis: Inject prepared sample supernatants and quantify based on peak area relative to the calibration curves.

## Conclusion: A Unified View for Drug Development

The study of penicillamine mixed disulfides is not an academic exercise; it is fundamental to understanding and improving the clinical use of this potent drug. By forming covalent adducts with endogenous molecules, penicillamine's actions are extended and diversified, leading to both desired therapeutic outcomes in conditions like cystinuria and severe, mechanism-based toxicities.

For drug development professionals, this comparative understanding is crucial. It underscores the necessity of employing advanced, specific analytical techniques like HPLC-ECD to move beyond measuring just the parent drug. A full pharmacokinetic/pharmacodynamic (PK/PD) profile must include the quantification of these bioactive disulfide metabolites. This detailed characterization is the only way to build robust models that can accurately predict clinical efficacy, anticipate adverse events, and ultimately lead to safer and more effective therapeutic strategies.

## References

- Wikipedia. Penicillamine. [[Link](#)]
- Cunningham, L. W., & Nuenke, B. J. (1960). Control of peptide disulfide regioisomer formation by mixed cysteine-penicillamine bridges. Application to endothelin-1. PubMed. [[Link](#)]
- Richie, J. P. Jr., & Lang, C. A. (1987). Determination of penicillamine, **penicillamine disulfide** and penicillamine-glutathione mixed disulfide by high-performance liquid chromatography with electrochemical detection. PubMed. [[Link](#)]

- Kagedal, B., Källberg, M., & Mårtensson, J. (1984). Determination of homocysteine, penicillamine, and their symmetrical and mixed disulfides by liquid chromatography with electrochemical detection. PubMed. [\[Link\]](#)
- Pediatric Oncall. Penicillamine - Mechanism, Indication, Contraindications, Dosing, Adverse Effect, Interaction, Renal Dose, Hepatic Dose. Drug Index. [\[Link\]](#)
- National Center for Biotechnology Information. Penicillamine. PubChem Compound Summary for CID 5852. [\[Link\]](#)
- Levine, B. B. (1960). Formation of D-penicillamine-cysteine mixed disulphide by reaction of D-benzylpenicilloic acid with cystine. PubMed. [\[Link\]](#)
- Tabachnick, M., Eisen, H. N., & Levine, B. (1954). A new mixed disulphide: penicillamine-cysteine. PubMed. [\[Link\]](#)
- Toni, M., & Tenti, S. (2023). Penicillamine. StatPearls - NCBI Bookshelf. [\[Link\]](#)
- Joyce, D. A. (1984). Methods for assaying D-penicillamine in a clinical setting. PubMed. [\[Link\]](#)
- Drugs.com. Penicillamine Tablets: Package Insert / Prescribing Info. [\[Link\]](#)
- Giorgi, M., & Yun, H. (2021). D-Penicillamine: The State of the Art in Humans and in Dogs from a Pharmacological and Regulatory Perspective. MDPI. [\[Link\]](#)
- Chvapil, M., & Chvapil, T. A. (2006). Synthesis and evaluation of long-acting D-penicillamine derivatives. PubMed. [\[Link\]](#)
- Felson, D. T., & Anderson, J. J. (1991). A comparison between bucillamine and D-penicillamine in the treatment of rheumatoid arthritis. PubMed. [\[Link\]](#)
- Huskisson, E. C. (1981). Other penicillamine-like drugs. PubMed. [\[Link\]](#)
- Netter, P., Bannwarth, B., & Pere, P. (1987). Clinical pharmacokinetics of D-penicillamine. PubMed. [\[Link\]](#)

- Winiarski, N., & Zasada, M. (2024). Penicillamine Revisited: Historic Overview and Review of the Clinical Uses and Cutaneous Adverse Effects. ResearchGate. [[Link](#)]
- El-Didamony, A. M. (2006). Penicillamine: Determination, Spectral and Antibacterial Studies as its Ru (III) Complex. International Journal of Pharmacology. [[Link](#)]
- Yeung, J. H., & Little, G. T. (1995). Reversibility of disulfide formation. Comparison of chemical and enzyme-mediated reduction of penicillamine and captopril disulfides. PubMed. [[Link](#)]

### Need Custom Synthesis?

BenchChem offers custom synthesis for rare earth carbides and specific isotopic labeling.

Email: [info@benchchem.com](mailto:info@benchchem.com) or [Request Quote Online](#).

## Sources

- [1. Penicillamine - Wikipedia \[en.wikipedia.org\]](#)
- [2. Penicillamine | C5H11NO2S | CID 5852 - PubChem \[pubchem.ncbi.nlm.nih.gov\]](#)
- [3. Penicillamine - Mechanism, Indication, Contraindications, Dosing, Adverse Effect, Interaction, Renal Dose, Hepatic Dose | Drug Index | Pediatric Oncall \[pediatriconcall.com\]](#)
- [4. Penicillamine - StatPearls - NCBI Bookshelf \[ncbi.nlm.nih.gov\]](#)
- [5. D-Penicillamine: The State of the Art in Humans and in Dogs from a Pharmacological and Regulatory Perspective \[mdpi.com\]](#)
- [6. Clinical pharmacokinetics of D-penicillamine - PubMed \[pubmed.ncbi.nlm.nih.gov\]](#)
- [7. Formation of D-penicillamine-cysteine mixed disulphide by reaction of D-benzylpenicilloic acid with cystine - PubMed \[pubmed.ncbi.nlm.nih.gov\]](#)
- [8. A new mixed disulphide: penicillamine-cysteine - PubMed \[pubmed.ncbi.nlm.nih.gov\]](#)
- [9. Penicillamine Tablets: Package Insert / Prescribing Info \[drugs.com\]](#)
- [10. Reversibility of disulfide formation. Comparison of chemical and enzyme-mediated reduction of penicillamine and captopril disulfides - PubMed \[pubmed.ncbi.nlm.nih.gov\]](#)
- [11. researchgate.net \[researchgate.net\]](#)

- [12. Determination of penicillamine, penicillamine disulfide and penicillamine-glutathione mixed disulfide by high-performance liquid chromatography with electrochemical detection - PubMed \[pubmed.ncbi.nlm.nih.gov\]](#)
- [13. Determination of homocysteine, penicillamine, and their symmetrical and mixed disulfides by liquid chromatography with electrochemical detection - PubMed \[pubmed.ncbi.nlm.nih.gov\]](#)
- [14. Methods for assaying D-penicillamine in a clinical setting - PubMed \[pubmed.ncbi.nlm.nih.gov\]](#)
- [To cite this document: BenchChem. \[A Comparative Guide to Penicillamine Mixed Disulfides for Drug Development Professionals\]. BenchChem, \[2026\]. \[Online PDF\]. Available at: \[https://www.benchchem.com/product/b1617911/docs#a-comparative-guide-to-penicillamine-mixed-disulfides-for-drug-development-professionals\]](#)

---

#### Disclaimer & Data Validity:

The information provided in this document is for Research Use Only (RUO) and is strictly not intended for diagnostic or therapeutic procedures. While BenchChem strives to provide accurate protocols, we make no warranties, express or implied, regarding the fitness of this product for every specific experimental setup.

**Technical Support:** The protocols provided are for reference purposes. Unsure if this reagent suits your experiment?

**Need Industrial/Bulk Grade?** [Request Custom Synthesis Quote](#)

## BenchChem

Our mission is to be the trusted global source of essential and advanced chemicals, empowering scientists and researchers to drive progress in science and industry.

#### Contact

Address: 3281 E Guasti Rd  
Ontario, CA 91761, United States  
Phone: (601) 213-4426  
Email: [info@benchchem.com](mailto:info@benchchem.com)

Contact our Ph.D. Support Team for a compatibility check