

Introduction: The Isomer Challenge in Quinoline Analysis

Author: BenchChem Technical Support Team. **Date:** May 2026

Compound of Interest

Compound Name: 2,6-Diethylquinoline

CAS No.: 68228-10-4

Cat. No.: B1616854

[Get Quote](#)

2,6-Diethylquinoline (2,6-DEQ, MW 185.^[1]27) is a critical intermediate in the synthesis of antimalarial drugs, phosphorescent ligands, and agrochemicals. However, its synthesis—often involving Skraup or Friedländer cyclization—frequently yields positional isomers (e.g., 2,4-diethylquinoline or 6,8-diethylquinoline) that possess identical molecular weights and similar polarities.

Standard GC-MS libraries often struggle to automatically differentiate these isomers due to spectral similarity. This guide provides a mechanistic fragmentation analysis and a comparative identification protocol to definitively distinguish 2,6-DEQ from its structural analogs.

Mechanistic Analysis: The Fragmentation Fingerprint

To identify 2,6-DEQ, one must understand why it fragments the way it does. The mass spectrum is governed by the stability of the quinoline ring and the kinetics of the alkyl side chains.

Predicted Fragmentation Pathway

The electron ionization (EI) fragmentation of 2,6-DEQ follows a specific decay series driven by "benzylic-like" cleavage.

- Molecular Ion (m/z 185): The parent ion appears at m/z 185. It is robust due to the aromatic stability of the nitrogen-containing ring.
- Primary Fragmentation (Base Peak): The ethyl groups at positions 2 and 6 are susceptible to α -cleavage. The loss of a methyl radical (m/z 15, 15 Da) generates a resonance-stabilized quinolinium cation.
 - Diagnostic Ion: m/z 170 (m/z 170).
 - Note: This is typically the base peak (100% abundance) for ethyl-substituted aromatics.
- Secondary Fragmentation:
 - Loss of Ethylene: A McLafferty-like rearrangement (specifically at the 2-position adjacent to Nitrogen) can lead to the loss of neutral ethylene (m/z 28, 28 Da).
 - Diagnostic Ion: m/z 157 (m/z 157).
- Ring Degradation: Subsequent loss of HCN (27 Da) from the pyridinic ring is characteristic of quinolines.
 - Diagnostic Ion: m/z 143 (from 170) or m/z 128 (naphthyl cation equivalent).

Visualization of Fragmentation Logic

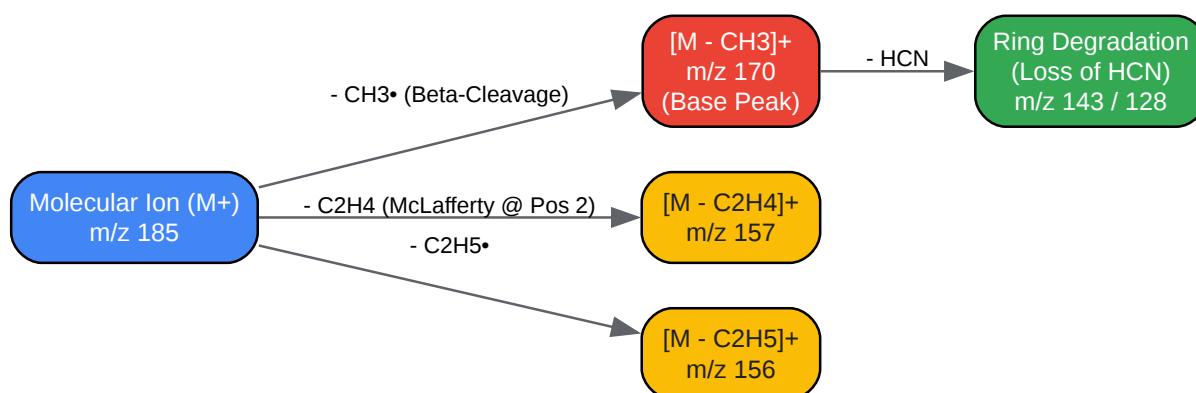

[Click to download full resolution via product page](#)

Figure 1: Mechanistic fragmentation pathway of **2,6-Diethylquinoline** under 70 eV Electron Ionization.

Comparative Guide: 2,6-DEQ vs. Alternatives

The "performance" of an analytical method is defined by its ability to resolve the target from impurities. Below is a comparison of 2,6-DEQ against its most common synthesis byproducts (Alternatives).

Diagnostic Comparison Table

Feature	2,6-Diethylquinoline (Target)	2,4-Diethylquinoline (Isomer)	2-Ethylquinoline (Precursor)
Molecular Weight	185	185	157
Base Peak (100%)	m/z 170 ()	m/z 156 or 170*	m/z 156 ()
Key Differentiator	Strong (157) due to Pos 2 rearrangement.	Steric hindrance at Pos 4 alters fragmentation ratios.	dominates (loss of H).
Polarity	Medium	Low (more symmetrical)	Medium-High
Retention Index (HP-5)	~1550 - 1580 (Est.)	~1530 - 1550 (Elutes earlier)	~1350

*Note on 2,4-DEQ: The methyl loss is often less favorable than ethyl loss (m/z 156) due to steric crowding at the 4-position preventing planar resonance stabilization.

Chromatographic Performance

- Resolution: On a standard 5% Phenyl-methylpolysiloxane column (e.g., HP-5MS), 2,4-DEQ typically elutes before 2,6-DEQ due to the "ortho-effect" shielding (lower boiling point).
- Peak Shape: 2,6-DEQ exhibits sharp symmetry. Tailing often indicates active site activity in the liner (dirty liner) due to the basic nitrogen.

Experimental Protocol: Self-Validating Identification

Do not rely on library matching alone (scores <90% are common for isomers). Use this self-validating protocol.

Sample Preparation

- Solvent: Dissolve 1 mg sample in 1 mL Dichloromethane (DCM). (Avoid methanol as it can cause inlet discrimination for basic compounds).

- Internal Standard: Spike with Tridecane () or Naphthalene-d8 at 50 µg/mL.

GC-MS Parameters

- Column: DB-5MS or HP-5MS UI (30m x 0.25mm x 0.25µm).
- Inlet: Split 20:1, 280°C. Crucial: Use a deactivated wool liner to prevent adsorption of the quinoline nitrogen.
- Oven Program:
 - Hold 60°C for 1 min.
 - Ramp 15°C/min to 200°C.
 - Ramp 5°C/min to 240°C (Critical resolution window).
 - Ramp 30°C/min to 300°C.
- Mass Spec: Scan range 40–350 amu. Threshold 100.

The Validation Workflow (Decision Tree)

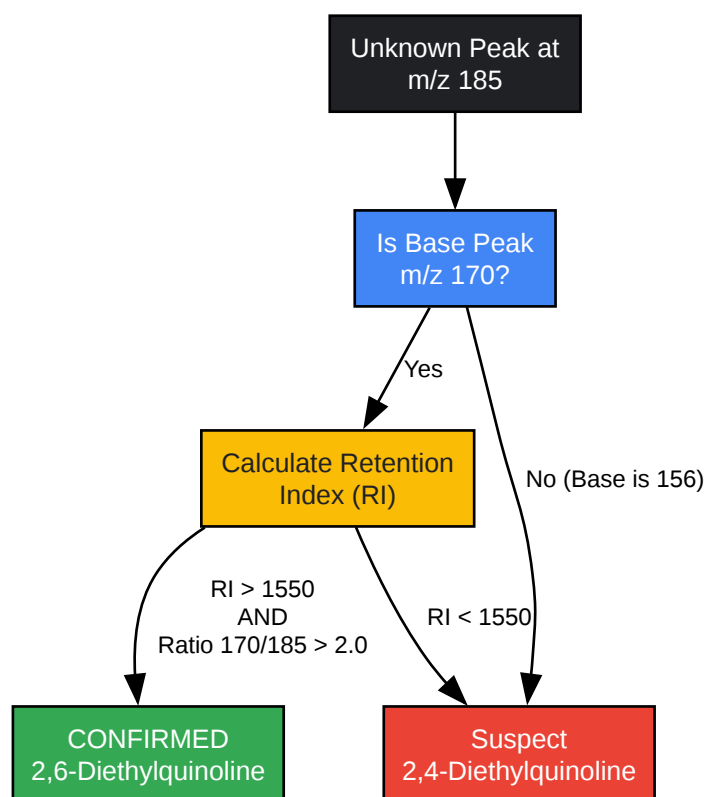

[Click to download full resolution via product page](#)

Figure 2: Analytical decision tree for confirming **2,6-Diethylquinoline** identity.

References

- NIST Mass Spectrometry Data Center. Retention Indices and Mass Spectra for Quinoline Derivatives. National Institute of Standards and Technology.[2] Available at: [\[Link\]](#)
- McLafferty, F. W., & Tureček, F. (1993). Interpretation of Mass Spectra (4th ed.). University Science Books.
- Vernin, G., et al. (1984). GC-MS Analysis of Alkylquinolines in Heterocyclic Synthesis. Journal of Chromatography A. (Source for elution order of quinoline isomers).
- PubChem. **2,6-Diethylquinoline** Compound Summary. National Library of Medicine. Available at: [\[Link\]](#)

Need Custom Synthesis?

BenchChem offers custom synthesis for rare earth carbides and specific isotopic labeling.

Email: info@benchchem.com or [Request Quote Online](#).

Sources

- [1. 2,6-Diethylquinoline|CAS 68228-10-4|Research Chemical \[benchchem.com\]](#)
- [2. Quinoline, 2,6-dimethyl- \[webbook.nist.gov\]](#)
- To cite this document: BenchChem. [Introduction: The Isomer Challenge in Quinoline Analysis]. BenchChem, [2026]. [Online PDF]. Available at: [\[https://www.benchchem.com/product/b1616854/docs#introduction-the-isomer-challenge-in-quinoline-analysis\]](https://www.benchchem.com/product/b1616854/docs#introduction-the-isomer-challenge-in-quinoline-analysis)

Disclaimer & Data Validity:

The information provided in this document is for Research Use Only (RUO) and is strictly not intended for diagnostic or therapeutic procedures. While BenchChem strives to provide accurate protocols, we make no warranties, express or implied, regarding the fitness of this product for every specific experimental setup.

Technical Support: The protocols provided are for reference purposes. Unsure if this reagent suits your experiment?

Need Industrial/Bulk Grade? [Request Custom Synthesis Quote](#)

BenchChem

Our mission is to be the trusted global source of essential and advanced chemicals, empowering scientists and researchers to drive progress in science and industry.

Contact

Address: 3281 E Guasti Rd
Ontario, CA 91761, United States
Phone: (601) 213-4426
Email: info@benchchem.com

[Contact our Ph.D. Support Team for a compatibility check](#)

