

Preventing hydrolysis of sulfonate esters during sample preparation

Author: BenchChem Technical Support Team. **Date:** May 2026

Compound of Interest

Compound Name: *1,4-Butanedisulfonic acid, dimethyl ester*

CAS No.: 4239-21-8

Cat. No.: B1615844

[Get Quote](#)

Technical Support Center: Sulfonate Ester Sample Preparation Ticket ID: SE-HYD-PREP-001

Status: Open Priority: Critical (Genotoxic Impurity Risk)

Introduction: The "Disappearing Impurity" Paradox

User Context: You are analyzing drug substances (APIs) for Alkyl Sulfonate Esters (Mesylates, Tosylates, Besylates). These are potent genotoxic impurities (GTIs) regulated under ICH M7.

The Problem: You observe poor recovery or inconsistent results. Spiked standards disappear before injection. The Root Cause: Sulfonate esters are reactive electrophiles. They are designed to alkylate DNA; in your sample vial, they will happily alkylate water (hydrolysis) or alcohols (transesterification), effectively destroying the evidence of their presence.

This guide provides the engineering controls and chemical protocols required to arrest this degradation during sample preparation.

Module 1: The Mechanism of Failure

To prevent loss, you must understand the enemy. Sulfonate esters degrade via an

nucleophilic substitution.

- Hydrolysis: Water acts as the nucleophile, displacing the sulfonate group and reverting the molecule to the sulfonic acid and alcohol. This reaction is base-catalyzed.[1]
- Transesterification: If you use Methanol (MeOH) as a diluent, the methoxide ion attacks, converting a Tosylate/Besylate into a Methyl ester (e.g., Methyl Tosylate), creating a false positive for a different GTI while eliminating the original target.

Visualizing the Degradation Pathway

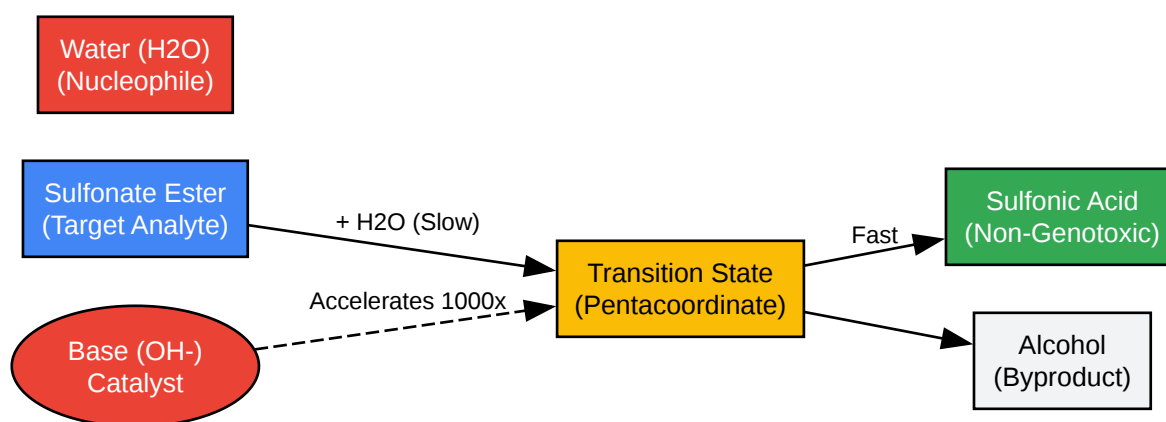

[Click to download full resolution via product page](#)

Figure 1: The degradation pathway. Note that hydroxide ions (high pH) act as a turbocharger for the destruction of your analyte.

Module 2: Diagnostic Workflow (Triage)

Before selecting a protocol, use this decision matrix to determine the safest approach for your specific API matrix.

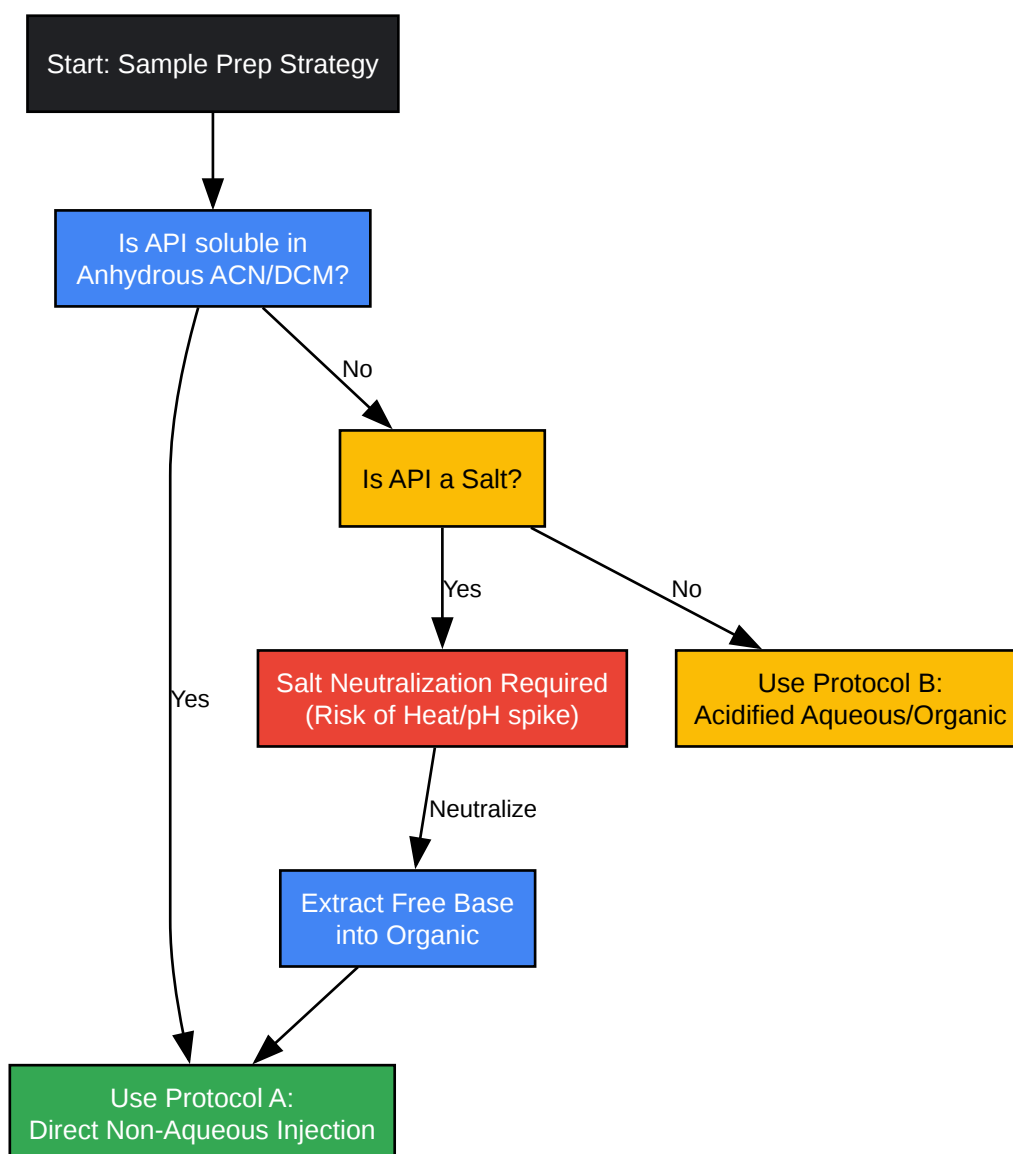

[Click to download full resolution via product page](#)

Figure 2: Workflow for selecting the extraction solvent. Anhydrous methods are always preferred.

Module 3: Optimized Protocols

Protocol A: The "Anhydrous Shield" (Gold Standard)

Best for: GC-MS analysis and APIs soluble in Acetonitrile (ACN) or Dichloromethane (DCM).

Principle: Elimination of the nucleophile (water) prevents the reaction entirely.

- Solvent Preparation:

- Use HPLC-grade Acetonitrile (ACN) or Dichloromethane (DCM).
- Critical Step: Add 3Å Molecular Sieves to the solvent bottle 24 hours prior to use to ensure water content is <0.05%.
- Sample Extraction:
 - Weigh API directly into a silanized amber vial (prevents surface adsorption).
 - Add Anhydrous Solvent.[1] Do not sonicate if possible (heat promotes degradation). Vortex briefly.
- Filtration:
 - Use PTFE or PVDF filters (hydrophobic).
 - Warning: Never use Nylon filters; they bind sulfonate esters, causing false negatives.
- Analysis:
 - Inject immediately via GC-MS.

Protocol B: Acidic Stabilization (When Water is Unavoidable)

Best for: HPLC analysis where the API requires aqueous dissolution. Principle: Low pH (< 2.5) protonates the leaving group less effectively than base catalyzes the attack, significantly slowing hydrolysis (metastable zone).

- Diluent Preparation:
 - Prepare a mixture of Water:Acetonitrile (e.g., 50:50).
 - Acidification: Add 0.1% Perchloric Acid or Phosphoric Acid. Target pH: 1.5 – 2.5.
 - Avoid: Acetic acid (too weak) or Hydrochloric acid (chloride ions can react to form alkyl chlorides—another GTI).

- Temperature Control:
 - Pre-chill the diluent to 4°C.
 - Set the autosampler tray to 4°C. Reaction rates double for every 10°C increase.
- Execution:
 - Dissolve API in the chilled, acidic diluent.
 - Inject immediately.
 - Self-Validation: Run a "Check Standard" every 5 injections. If the area count drops >5%, your stability window has closed.

Module 4: Stability Data & Solvent Compatibility

The following table summarizes the half-life risks associated with common laboratory conditions.

Parameter	Condition	Risk Level	Estimated Half-Life (Mesylates)
pH	pH > 8 (Basic)	CRITICAL	< 10 Minutes
pH 7 (Neutral)	HIGH	1 - 4 Hours	
pH < 3 (Acidic)	LOW	> 24 Hours	
Solvent	Methanol (MeOH)	CRITICAL	Transesterification (False Positives)
DMSO/Water	MEDIUM	Hydrolysis dependent on water %	
Anhydrous ACN	SAFE	Stable (> 48 Hours)	
Temp	Ambient (25°C)	MEDIUM	Variable
Chilled (4°C)	LOW	Stable	

Module 5: Frequently Asked Questions (FAQ)

Q: Can I use Methanol to dissolve my sample if I inject immediately? A: NO. Methanol is a nucleophile. In the presence of any residual sulfonic acid (from the salt formation), Methanol will react to form Methyl Esters (e.g., Methyl Methanesulfonate - MMS). This creates a GTI in situ that was not in the original drug. Always use Acetonitrile or Acetone.

Q: My API is a Mesylate salt. Doesn't dissolving it release the GTI? A: This is a common misconception. Dissolving a Mesylate salt releases the Mesylate anion (non-genotoxic). The GTI is the covalent ester (Alkyl Mesylate). However, if you dissolve a Mesylate salt in an alcohol, you risk forming the ester. Always dissolve Mesylate salts in non-alcoholic solvents for GTI analysis.

Q: How do I validate that my sample prep isn't destroying the impurity? A: Perform a Spike-Recovery Study.

- Spike the API with the sulfonate ester standard at the Limit of Quantitation (LOQ) level.
- Prepare the sample using your proposed protocol.
- Wait 1 hour (simulating autosampler dwell time).
- Analyze.^{[2][3][4][5][6]}
- Pass Criteria: Recovery must be between 80-120%. If <80%, hydrolysis is occurring.

Q: Which filter membrane should I use? A: Hydrophobic PTFE (Polytetrafluoroethylene) or PVDF.

- Avoid: Nylon and Cellulose Acetate. These materials contain functional groups that can interact with or bind the electron-deficient sulfonate ester, stripping it from the solution.

References

- Teasdale, A., et al. (2013). "Mechanism and processing parameters affecting the formation of sulfonate esters: A case study." Organic Process Research & Development. [Link](#)

- Elder, D. P., et al. (2009). "Regulating Genotoxic Impurities." Journal of Pharmaceutical and Biomedical Analysis. [Link](#)
- International Council for Harmonisation (ICH). (2017). "ICH M7(R1): Assessment and Control of DNA Reactive (Mutagenic) Impurities in Pharmaceuticals." [Link](#)
- Wolfe, N. L., et al. (1980). "Hydrolysis of Methyl Methanesulfonate and Ethyl Methanesulfonate." Environmental Science & Technology. [Link](#)

Need Custom Synthesis?

BenchChem offers custom synthesis for rare earth carbides and specific isotopic labeling.

Email: info@benchchem.com or [Request Quote Online](#).

Sources

- 1. pdf.benchchem.com [pdf.benchchem.com]
- 2. pqri.org [pqri.org]
- 3. portal.research.lu.se [portal.research.lu.se]
- 4. enovatia.com [enovatia.com]
- 5. jes-tm.org [jes-tm.org]
- 6. scispace.com [scispace.com]
- To cite this document: BenchChem. [Preventing hydrolysis of sulfonate esters during sample preparation]. BenchChem, [2026]. [Online PDF]. Available at: [<https://www.benchchem.com/product/b1615844/docs#preventing-hydrolysis-of-sulfonate-esters-during-sample-preparation>]

Disclaimer & Data Validity:

The information provided in this document is for Research Use Only (RUO) and is strictly not intended for diagnostic or therapeutic procedures. While BenchChem strives to provide accurate protocols, we make no warranties, express or implied, regarding the fitness of this product for every specific experimental setup.

Technical Support: The protocols provided are for reference purposes. Unsure if this reagent suits your experiment?

Need Industrial/Bulk Grade? [Request Custom Synthesis Quote](#)

BenchChem

Our mission is to be the trusted global source of essential and advanced chemicals, empowering scientists and researchers to drive progress in science and industry.

Contact

Address: 3281 E Guasti Rd
Ontario, CA 91761, United States
Phone: (601) 213-4426
Email: info@benchchem.com

[Contact our Ph.D. Support Team for a compatibility check](#)