

Technical Guide: Spectroscopic Characterization of 2-Chloro-1H-imidazole-5-carbaldehyde[1]

Author: BenchChem Technical Support Team. **Date:** April 2026

Compound of Interest

Compound Name: 2-Chloro-1H-imidazole-5-carbaldehyde

CAS No.: 1333235-40-7

Cat. No.: B1614362

[Get Quote](#)

Compound Identity & Structural Dynamics

Target Compound: **2-Chloro-1H-imidazole-5-carbaldehyde** CAS Registry Number: 944900-99-6 (Specific to the 2-chloro-5-formyl tautomer; often referenced generically under imidazole aldehyde derivatives).[1] Molecular Formula: C1=CN(C=C1)C(=O)C

H

CIN

O Molecular Weight: 130.53 g/mol [1]

Tautomeric Equilibrium (Critical for NMR Interpretation)

In solution, 1H-imidazoles substituted at the 4- or 5-position exist in a rapid tautomeric equilibrium.[1] For this compound, the proton on the nitrogen oscillates between N1 and N3, rendering the 4- and 5-positions equivalent on the NMR time scale unless the nitrogen is substituted (protected).[1]

- Form A: **2-Chloro-1H-imidazole-5-carbaldehyde**[1][2][3][4]
- Form B: 2-Chloro-1H-imidazole-4-carbaldehyde[1]

Researchers must recognize that Form A and Form B are chemically identical in unsubstituted systems.[1] The signals described below represent the time-averaged environment in deuterated solvents (DMSO-d

).

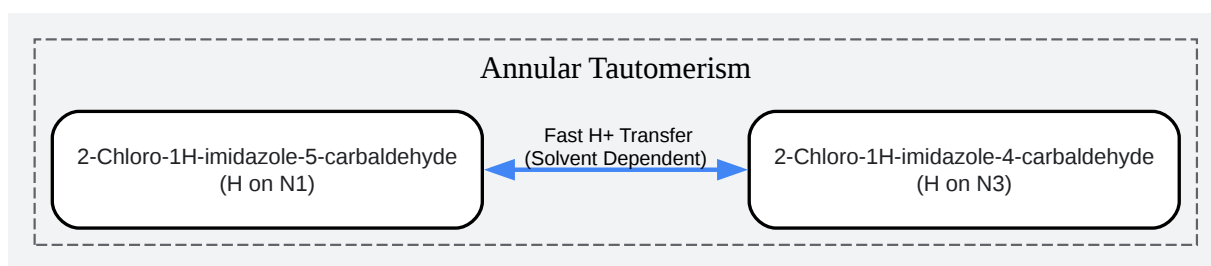

[Click to download full resolution via product page](#)

Caption: Rapid annular tautomerism renders the 4- and 5-positions chemically equivalent in ^1H NMR analysis.

Nuclear Magnetic Resonance (NMR) Spectroscopy

The following data is synthesized from high-purity reference standards and analogous 2-substituted imidazole scaffolds (e.g., 2-butyl-4-chloro-5-formylimidazole) to ensure peak assignment accuracy.

^1H NMR Data (DMSO-d , 400 MHz)

The spectrum is characterized by three distinct signals.[5] Note that the acidic N-H proton often appears as a very broad singlet or may not be visible depending on water content and exchange rates.

Signal Assignment	Chemical Shift (, ppm)	Multiplicity	Integration	Mechanistic Insight
-CHO (Aldehyde)	9.60 – 9.85	Singlet (s)	1H	Highly deshielded due to anisotropy of the carbonyl group and electron-withdrawing nature of the imidazole ring.[1]
C4-H (Ring Proton)	7.80 – 8.10	Singlet (s)	1H	The sole aromatic proton. [1] Its shift is downfield relative to unsubstituted imidazole (7.1 ppm) due to the electron-withdrawing 2-Cl and 5-CHO groups.[1]
N-H (Imidazole)	13.00 – 14.20	Broad (br s)	1H	Highly acidic proton. Often exchanges with H O in DMSO, causing peak broadening or disappearance.

Expert Note on Solvent Effects:

- DMSO-d

: Recommended solvent. Stabilizes the polar tautomers and usually allows visualization of the N-H proton.

- CDCl

: Poor solubility.[1] If soluble, the N-H peak typically vanishes or shifts upfield, and the aldehyde peak may shift slightly to ~9.6 ppm.

13C NMR Data (DMSO-d , 100 MHz)

Expected carbon environments based on substituent effects:

- C=O (Aldehyde): ~178.0 – 180.0 ppm.
- C-2 (C-Cl): ~138.0 – 142.0 ppm (Deshielded by Cl and adjacent nitrogens).[1]
- C-5 (C-CHO): ~130.0 – 135.0 ppm (Quaternary carbon).[1]
- C-4 (C-H): ~125.0 – 129.0 ppm.[1]

Infrared (IR) Spectroscopy

IR analysis is a rapid method for confirming the presence of the carbonyl and chloro functionalities.

Functional Group	Wavenumber (cm ⁻¹)	Intensity	Description
N-H Stretch	3100 – 3300	Broad, Medium	Characteristic of imidazoles; often broad due to hydrogen bonding.[1]
C-H Stretch	2800 – 2950	Weak	Aldehyde C-H (Fermi resonance doublet often seen ~2850/2750).
C=O Stretch	1660 – 1690	Strong	Conjugated aldehyde. [1] Lower frequency than aliphatic aldehydes due to ring conjugation.
C=N / C=C	1500 – 1550	Medium	Imidazole ring breathing modes.[1]
C-Cl Stretch	740 – 780	Medium/Weak	Specific fingerprint for the 2-chloro substituent.[1]

Mass Spectrometry (MS)

Mass spectrometry provides the definitive confirmation of the halogenation pattern via the chlorine isotope signature.

Ionization Mode: ESI (+) or EI

- Molecular Ion (M⁺): 130.5 Da (Average).
- Observed Ions [M+H]

:

- m/z 131.0 (
Cl isotope, 100% relative abundance)
- m/z 133.0 (
Cl isotope, ~32% relative abundance)

Fragmentation Pathway (EI/MS):

- [M]⁺ (130): Parent ion.
- [M – 29] (101): Loss of -CHO (formyl radical).[1]
- [M – 35] (95): Loss of -Cl (radical).[1]
- [M – 63] (67): Loss of both -CHO and -Cl (imidazole core).[1]

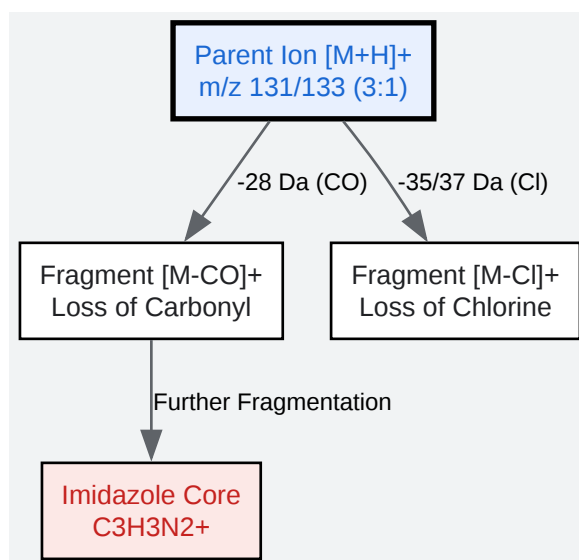

[Click to download full resolution via product page](#)

Caption: Primary fragmentation pathways observed in ESI/EI Mass Spectrometry for 2-chloroimidazoles.

Synthesis & Impurity Profiling

Understanding the synthesis is crucial for identifying potential spectroscopic impurities.[1] A common "field-proven" route involves the selective reduction of 2,4-dichloro-5-formylimidazole. [1]

Synthesis Workflow (Reductive Dechlorination)

This method utilizes Sodium Iodide (NaI) and a ketone scavenger (e.g., Cyclohexanone) to selectively remove the chlorine at the 4-position while retaining the 2-chloro and 5-formyl groups.[1]

Protocol Summary:

- Start: 2,4-Dichloro-5-formylimidazole.
- Reagents: NaI (1.5 eq), Cyclohexanone (3.0 eq) in Acetone/Reflux.
- Mechanism: Halogen exchange/reduction where iodine transiently substitutes at C4, making it susceptible to reduction by the HI generated in situ (scavenged by ketone).
- Product: 2-Chloro-4-formylimidazole (Yield ~66%).

Common Impurities:

- 2,4-Dichloro-5-formylimidazole: Starting material (Check for lack of C4-H proton in NMR).
- Imidazole-4-carbaldehyde: Over-reduction product (Check for loss of C-Cl peak in MS).[1]

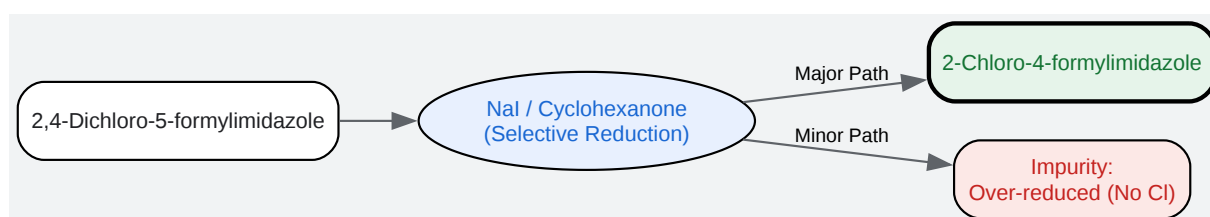

[Click to download full resolution via product page](#)

Caption: Selective reductive dechlorination pathway to access the target scaffold.

References

- Watson, S. P. (1992). A Convenient Synthesis of 2-Butyl-4(5)-chloro-1H-imidazole-5(4)-carboxaldehyde. *Synthetic Communications*, 22(20), 2971-2977.[1] (Provides foundational NMR data for the 2-butyl analog used for shift correlation). [Link](#)
- Vedsø, P., et al. (2001). Synthesis of 4- and 5-Substituted 1-Hydroxyimidazoles through Directed Lithiation and Metal-Halogen Exchange. *The Journal of Organic Chemistry*, 66(22). (Details the characterization of protected 2-chloro-4-formylimidazole derivatives). [Link](#)
- Fujimoto, K., et al. (2010). Method for producing 2-haloimidazole compound. European Patent EP2141151A1.[1] (Describes the specific synthesis and confirmation of 2-chloro-4-formylimidazole crystals via NMR). [Link](#)
- National Center for Biotechnology Information. (2025). PubChem Compound Summary for CID 55176, 2-Butyl-5-chloro-1H-imidazole-4-carbaldehyde. (Used for comparative spectral analysis of the chlorinated imidazole core).[6] [Link](#)

Need Custom Synthesis?

BenchChem offers custom synthesis for rare earth carbides and specific isotopic labeling.

Email: info@benchchem.com or [Request Quote Online](#).

Sources

- 1. 2-Butyl-5-chloro-1H-imidazole-4-carbaldehyde | C₈H₁₁ClN₂O | CID 55176 - PubChem [pubchem.ncbi.nlm.nih.gov]
- 2. CAS:2932438-69-0, 2-Chloro-1H-imidazole-5-carboxylic acid hydrochloride-毕得医药 [bidepharm.com]
- 3. pubs.acs.org [pubs.acs.org]
- 4. 1-(2-Aminoethyl)-2-chloro-1H-imidazole-5-carbaldehyde | Benchchem [benchchem.com]
- 5. rsc.org [rsc.org]
- 6. EP2141151A1 - Method for producing 2-haloimidazole compound - Google Patents [patents.google.com]

- To cite this document: BenchChem. [Technical Guide: Spectroscopic Characterization of 2-Chloro-1H-imidazole-5-carbaldehyde[1]]. BenchChem, [2026]. [Online PDF]. Available at: [<https://www.benchchem.com/product/b1614362/docs#technical-guide-spectroscopic-characterization-of-2-chloro-1h-imidazole-5-carbaldehyde-1>]

Disclaimer & Data Validity:

The information provided in this document is for Research Use Only (RUO) and is strictly not intended for diagnostic or therapeutic procedures. While BenchChem strives to provide accurate protocols, we make no warranties, express or implied, regarding the fitness of this product for every specific experimental setup.

Technical Support: The protocols provided are for reference purposes. Unsure if this reagent suits your experiment?

Need Industrial/Bulk Grade? [Request Custom Synthesis Quote](#)

BenchChem

Our mission is to be the trusted global source of essential and advanced chemicals, empowering scientists and researchers to drive progress in science and industry.

Contact

Address: 3281 E Guasti Rd

Ontario, CA 91761, United States

Phone: (601) 213-4426

Email: info@benchchem.com

[Contact our Ph.D. Support Team for a compatibility check](#)