

Technical Guide: Derivatives & Reactivity of 2-Chloro-1H-imidazole-5-carbaldehyde

Author: BenchChem Technical Support Team. **Date:** April 2026

Compound of Interest

Compound Name: *2-Chloro-1H-imidazole-5-carbaldehyde*

CAS No.: *1333235-40-7*

Cat. No.: *B1614362*

[Get Quote](#)

Executive Summary: The "Tri-Vector" Scaffold

2-Chloro-1H-imidazole-5-carbaldehyde represents a privileged "tri-vector" scaffold in drug discovery. Unlike its more famous alkylated cousin (the Losartan intermediate, 2-butyl-4-chloro-5-formylimidazole), this unsubstituted core offers three orthogonal points of diversity without the steric bulk of a fixed alkyl chain.

- Vector 1 (C5-Formyl): A highly reactive electrophile for reductive aminations, condensations, and heterocycle formation.
- Vector 2 (C2-Chloro): A latent handle for nucleophilic aromatic substitution (S_NAr) or transition-metal catalyzed cross-couplings (Suzuki, Buchwald-Hartwig).
- Vector 3 (N1-H): An acidic nitrogen amenable to alkylation or arylation to tune solubility and pharmacokinetic (PK) profiles.

This guide provides the protocols and mechanistic insights required to exploit these vectors for library generation.

Reactivity Landscape

The following diagram maps the logical flow of chemical space accessible from this core.

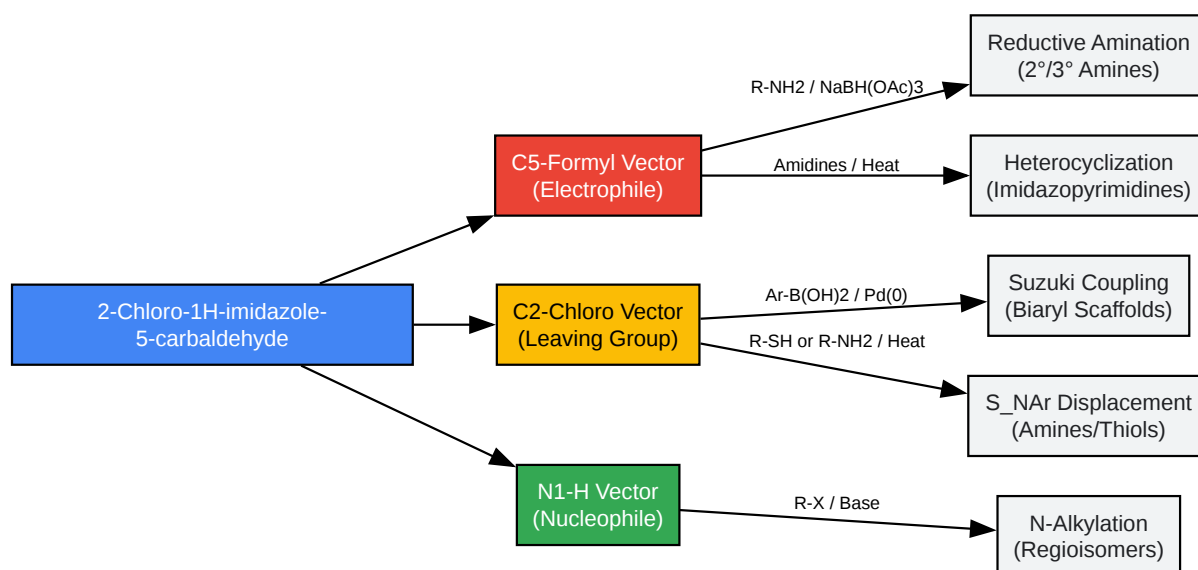

[Click to download full resolution via product page](#)

Figure 1: Orthogonal reactivity vectors of the **2-chloro-1H-imidazole-5-carbaldehyde** scaffold.

Derivative Class A: C5-Functionalization (The "Warhead")

The C5-aldehyde is the most reactive handle. It is distinct from benzaldehydes due to the electron-rich imidazole ring, yet the electron-withdrawing nature of the adjacent imine nitrogen (N3) and the C2-chlorine enhances its electrophilicity compared to simple imidazoles.

Reductive Amination

This is the primary route for generating diversity. The reaction proceeds via an iminium ion intermediate.

- Mechanism: Formation of the carbinolamine

dehydration to imine/iminium

hydride reduction.

- Critical Insight: Use Sodium Triacetoxyborohydride (STAB) instead of Sodium Borohydride (). STAB is milder and prevents the direct reduction of the aldehyde to the alcohol (a common side reaction with) before the imine is formed.

Protocol 1: General Reductive Amination

- Imine Formation: Dissolve **2-Chloro-1H-imidazole-5-carbaldehyde** (1.0 eq) and the Amine (1.1 eq) in 1,2-Dichloroethane (DCE) or THF.
- Acid Catalysis: Add Acetic Acid (1.0–2.0 eq) to catalyze imine formation. Stir for 1–2 hours at room temperature.
 - Note: Monitoring by TLC/LCMS usually shows the disappearance of the aldehyde.
- Reduction: Add Sodium Triacetoxyborohydride (1.5 eq) in one portion.
- Workup: Stir for 4–16 hours. Quench with saturated aqueous . Extract with EtOAc or DCM.
- Purification: Flash chromatography (DCM/MeOH gradients).

Heterocyclization (Imidazo-fused systems)

Condensation with binucleophiles (e.g., amidines, guanidines, or 1,2-diamines) builds fused ring systems.

- Target: Imidazo[1,2-a]pyrimidines or Imidazo[2,1-b]thiazoles.[1]
- Reagent: 2-Aminopyrimidine or thiourea derivatives.

Derivative Class B: C2-Functionalization (The "Anchor")

The C2-position is flanked by two nitrogens, making it electron-deficient. The chlorine atom is a viable leaving group, activated further by the electron-withdrawing formyl group at C5.

Suzuki-Miyaura Cross-Coupling

This reaction replaces the chlorine with an aryl or heteroaryl group.

- Challenge: Imidazole nitrogens can coordinate to Palladium, poisoning the catalyst.
- Solution: Use N-protection (e.g., SEM, Boc) prior to coupling, or use robust catalyst systems like Pd(dppf)Cl₂ or XPhos Pd G2.

Protocol 2: C2-Arylation (Suzuki)

- Setup: In a microwave vial, combine **2-Chloro-1H-imidazole-5-carbaldehyde** (1.0 eq), Aryl Boronic Acid (1.5 eq), and (3.0 eq).
- Solvent: Add a degassed mixture of Dioxane:Water (4:1).
- Catalyst: Add Pd(dppf)Cl₂-DCM (5 mol%).
- Reaction: Seal and heat to 100°C for 2–12 hours (or 120°C for 30 min in microwave).
- Workup: Filter through Celite, dilute with water, extract with EtOAc.

Nucleophilic Aromatic Substitution ()

While less reactive than 2-chloropyridine, the 2-chloroimidazole can undergo displacement with strong nucleophiles (thiols, alkoxides) or amines under forcing conditions.

- Conditions: DMF/DMSO, , Base (

or NaH).

Derivative Class C: N1-Alkylation (Solubility & PK)

N-alkylation is often the first step in library synthesis to block the acidic proton and improve solubility in organic solvents.

Regioselectivity (N1 vs N3)

Alkylation of 4(5)-substituted imidazoles typically yields a mixture of regioisomers.

- Sterics vs. Thermodynamics:
 - N1-Alkylation (Desired): Places the alkyl group distal to the C5-formyl group (1,5-disubstitution pattern).
 - N3-Alkylation (Common byproduct): Places the alkyl group proximal to the C5-formyl group (1,4-disubstitution pattern).
- Control Strategy:
 - Base Selection:

in DMF often favors the 1,4-isomer (N3 attack) due to chelation/hydrogen bonding effects.
 - Trityl Protection: Use Trityl chloride (Trt-Cl) to sterically block one nitrogen, then alkylate the other, though this is often used for transient protection.

Table 1: Regioselectivity Trends in Alkylation

Conditions	Major Isomer	Rationale
NaH / DMF / R-X	Mixture (often ~1:1)	Rapid, irreversible deprotonation.
/ Acetone / R-X	N1-Alkyl (1,5-product)	Thermodynamic control; steric hindrance minimizes N3 attack.
Mitsunobu (R-OH)	N1-Alkyl (1,5-product)	Steric bulk of adduct directs attack to less hindered N.

Synthesis of the Core Scaffold[3][4]

If the core is not purchased, it is synthesized via the Vilsmeier-Haack reaction on 2-chloroimidazole or a cyclization strategy.

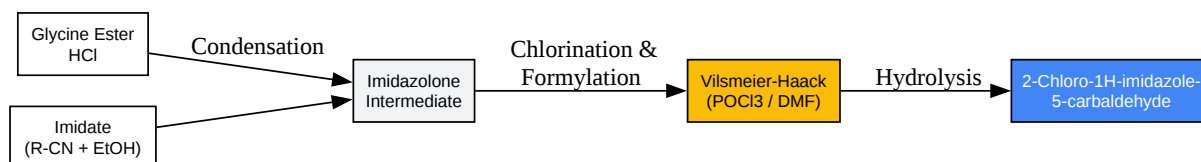

[Click to download full resolution via product page](#)

Figure 2: Synthetic route to the 2-chloro-5-formylimidazole core.

The Vilsmeier-Haack step is "double-duty": it converts the imidazolone (carbonyl) to a chloroimidazole and installs the formyl group at the C5 position simultaneously.

References

- Watson, S. P. (1992). A Convenient Synthesis of 2-Butyl-4(5)-chloro-1H-imidazole-5(4)-carboxaldehyde. *Synthetic Communications*. [Link](#)
 - Core synthesis methodology via Vilsmeier-Haack.

- Larsen, R. D., et al. (1994). Efficient Synthesis of Losartan, A Nonpeptide Angiotensin II Receptor Antagonist. *Journal of Organic Chemistry*. [Link](#)
 - Definitive guide on regioselective alkylation and reactivity of chloro-formyl-imidazoles.
- Bellina, F., & Rossi, R. (2006). Synthesis and Biological Activity of 2-Substituted Imidazoles. *Current Medicinal Chemistry*. Review of C2-functionalization strategies including Suzuki and Stille couplings.
- Grimmett, M. R. (1997). *Imidazole and Benzimidazole Synthesis*. Academic Press. Authoritative text on imidazole tautomerism and reactivity.

Need Custom Synthesis?

BenchChem offers custom synthesis for rare earth carbides and specific isotopic labeling.

Email: info@benchchem.com or [Request Quote Online](#).

Sources

- 1. Novel regioselective hydroxyl-alkylation of 4,5-diphenylimidazole-2-thione and a competitive intramolecular ring closure of the S-hydroxyalkyl-imidazoles to imidazo[2,1-b]thiazines and thiazoles. Role of catalyst, microwave irradiation, and solid support - PubMed [pubmed.ncbi.nlm.nih.gov]
- To cite this document: BenchChem. [Technical Guide: Derivatives & Reactivity of 2-Chloro-1H-imidazole-5-carbaldehyde]. BenchChem, [2026]. [Online PDF]. Available at: [<https://www.benchchem.com/product/b1614362/docs#technical-guide-derivatives-reactivity-of-2-chloro-1h-imidazole-5-carbaldehyde>]

Disclaimer & Data Validity:

The information provided in this document is for Research Use Only (RUO) and is strictly not intended for diagnostic or therapeutic procedures. While BenchChem strives to provide accurate protocols, we make no warranties, express or implied, regarding the fitness of this product for every specific experimental setup.

Technical Support: The protocols provided are for reference purposes. Unsure if this reagent suits your experiment?

Need Industrial/Bulk Grade? [Request Custom Synthesis Quote](#)

BenchChem

Our mission is to be the trusted global source of essential and advanced chemicals, empowering scientists and researchers to drive progress in science and industry.

Contact

Address: 3281 E Guasti Rd
Ontario, CA 91761, United States
Phone: (601) 213-4426
Email: info@benchchem.com

[Contact our Ph.D. Support Team for a compatibility check](#)