

Mass Spectrometry Fragmentation Patterns of Phenalene-1-one Derivatives

Author: BenchChem Technical Support Team. **Date:** May 2026

Compound of Interest

Compound Name: 2,3-Dihydro-1H-phenalen-1-one

CAS No.: 518-85-4

Cat. No.: B1614757

[Get Quote](#)

Content Type: Technical Comparison Guide Audience: Senior Researchers, Medicinal Chemists, Analytical Scientists Focus: Structural Elucidation, Isobaric Differentiation, and Mechanistic Pathways

Executive Summary: The Phenalenone Core

Phenalene-1-one ($C_{13}H_8O$, MW 180.20) is a rigid, planar polycyclic aromatic ketone. Its fragmentation behavior is dominated by its high stability and the thermodynamic drive to extrude carbon monoxide (CO). Unlike flexible aliphatic ketones, the phenalenone core resists fragmentation until high internal energies are reached, making the molecular ion (M^+) typically the base peak or highly abundant.

Critical Analytical Challenge: Phenalene-1-one is isobaric with 9-fluorenone (MW 180.20). Both share the formula $C_{13}H_8O$ and exhibit similar primary fragmentation (loss of CO). Definitive identification requires analysis of secondary fragmentation intensities and, ideally, retention time data or MS/MS transitions.

Core Fragmentation Mechanisms

The fragmentation of phenalene-1-one under Electron Ionization (EI) follows a predictable "unzipping" of the ring system initiated by the loss of the carbonyl functionality.

Primary Pathway: The CO Extrusion

- Precursor: Molecular Ion $[M]^{+\bullet}$ (m/z 180)
- Mechanism: The radical cation localizes on the oxygen. Homolytic cleavage of the C-C bonds adjacent to the carbonyl leads to the extrusion of neutral carbon monoxide (CO, 28 Da).
- Product: The resulting ion is the acenaphthylene radical cation (m/z 152).
- Significance: This is the diagnostic transition for the phenalenone scaffold. The stability of the acenaphthylene product makes this a favored pathway.

Secondary Pathway: Acetylene Loss

- Precursor: Acenaphthylene radical cation (m/z 152)
- Mechanism: The strained 5-membered ring of the acenaphthylene ion opens, followed by the loss of a neutral acetylene molecule (C_2H_2 , 26 Da).
- Product: Naphthalene radical cation (m/z 126).
- Tertiary Loss: Further loss of C_2H_2 yields the m/z 100 ion (phenyldiacetylene cation).

Diagram: Fragmentation Tree (DOT Visualization)

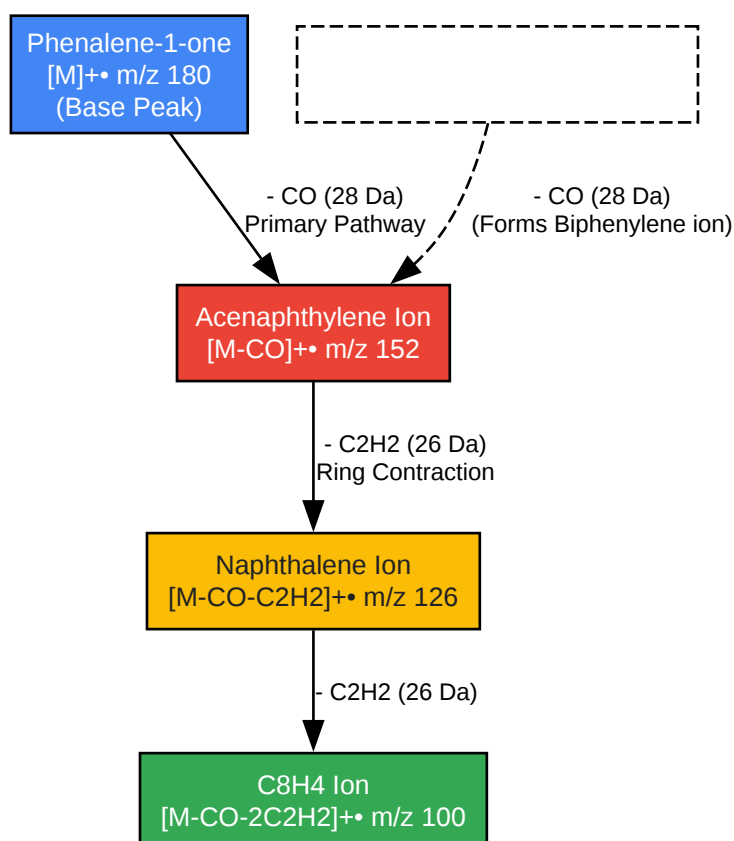

[Click to download full resolution via product page](#)

Figure 1: Mechanistic fragmentation tree for Phenalene-1-one showing the sequential loss of CO and Acetylene. The isobaric interference from Fluorenone is noted.

Comparative Analysis: Phenalenone vs. Alternatives

The primary alternative/interference is 9-Fluorenone. While their primary ions are identical, their secondary fragmentation energetics differ due to the stability of the intermediate ions.

Feature	Phenalene-1-one (Target)	9-Fluorenone (Alternative)	9-Hydroxyphenalene (Derivative)
Molecular Weight	180.20	180.20	196.20
Base Peak (EI)	m/z 180 (M ⁺)	m/z 180 (M ⁺)	m/z 196 (M ⁺)
Primary Fragment	m/z 152 [M-CO]	m/z 152 [M-CO]	m/z 168 [M-CO]
Secondary Fragment	m/z 126 [152-C ₂ H ₂]	m/z 126 [152-C ₂ H ₂]	m/z 140 [168-CO] (Double CO loss)
Diagnostic Ratio	High m/z 152 stability (Acenaphthylene)	Lower m/z 152 stability (Biphenylene)	Presence of [M-H] due to OH
Key Differentiator	m/z 151 is often weaker than in fluorenone. ^[1]	m/z 151 often significant (H-loss from biphenylene).	m/z 139/140 (Loss of 2xCO)

Scientist's Note: In 9-Hydroxyphenalene, the "Double CO Loss" is a hallmark. The first CO comes from the ketone, and the second involves the phenolic oxygen, often requiring a ring contraction rearrangement.

Derivative-Specific Patterns

Modifying the phenalene core alters the fragmentation pathway significantly.

A. Hydroxy-Phenalenones (e.g., 9-Hydroxy)^{[2][3]}

- Tautomerism: 9-hydroxyphenalene exists in a strong intramolecular H-bonded state.
- Fragmentation:
 - [M-H]⁺ (m/z 195): Significant due to the stability of the radical on the oxygen chelate.
 - [M-CO]⁺ (m/z 168): Loss of the carbonyl carbon.
 - [M-2CO]⁺ (m/z 140): A distinct pathway not seen in the parent phenalene. This suggests the hydroxyl oxygen is incorporated into a second CO elimination event.

B. Amino-Phenalenones

- Nitrogen Rule: Odd molecular weight (e.g., 1-aminophenalenone, MW 195).
- Fragmentation:
 - $[M-HCN]^+$: Loss of 27 Da is characteristic of aromatic amines.
 - $[M-CO]^+$: Still present but competes with HCN loss.

Experimental Protocol: Self-Validating Workflow

To ensure data integrity when analyzing these compounds, follow this validated workflow.

Step 1: Sample Preparation

- Solvent: Dissolve 0.1 mg of sample in Dichloromethane (DCM) or Methanol (MeOH). Avoid acetone (can form adducts).
- Concentration: 10 ppm for EI; 1 ppm for ESI.

Step 2: Ionization & Acquisition

- EI Mode (70 eV): Use for structural fingerprinting.
 - Validation: Check m/z 28 (N_2) and m/z 32 (O_2) background.
 - Scan Range: m/z 40–300.
- ESI Mode (+/-): Use for derivatives (OH, NH_2).
 - Validation: Observe $[M+H]^+$ and $[M+Na]^+$ adducts to confirm MW.
 - In-Source CID: Apply 20-40V cone voltage to induce the diagnostic $[M-CO]$ fragment.

Step 3: Data Interpretation (The Logic Check)

- Identify Parent: Is M^+ (EI) or $[M+H]^+$ (ESI) the base peak? (It should be).
- Check CO Loss: Do you see $M-28$?

- Yes: Consistent with Phenalenone/Fluorenone.
- No: Check for aliphatic chains or non-ketone isomers.
- Check Secondary Loss: Do you see M-54 (Loss of CO + C₂H₂)?
 - Yes: Confirms the aromatic core.[\[2\]](#)[\[3\]](#)

Diagram: Experimental Workflow (DOT)

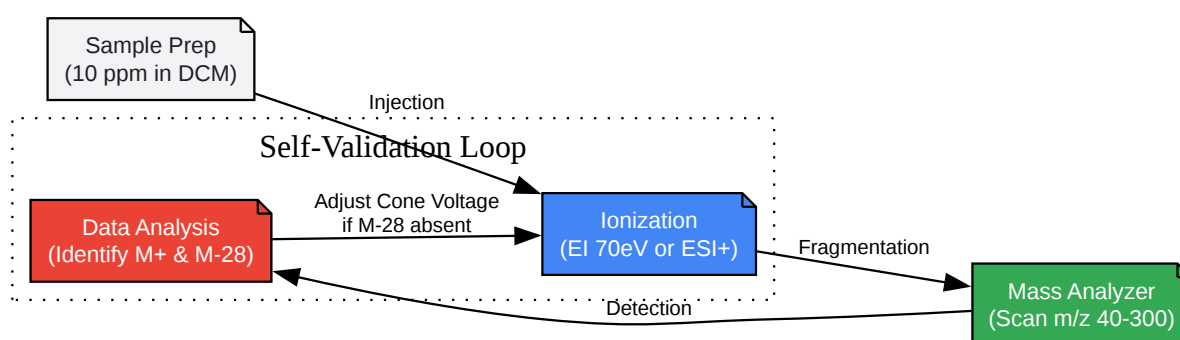

[Click to download full resolution via product page](#)

Figure 2: Standardized workflow for MS characterization of phenalenone derivatives.

References

- NIST Mass Spectrometry Data Center. Mass Spectrum of 1H-Phenalene and Fluorenone. National Institute of Standards and Technology. Available at: [\[Link\]](#)
- Haddon, R. C., et al. (2020). New Phenalenone Derivatives: Synthesis and Evaluation of Their Singlet Oxygen Quantum Yield. ACS Omega.
- ChemLibreTexts. Mass Spectrometry Fragmentation Patterns: Aromatic Ketones. Available at: [\[Link\]](#)
- PubChem. 9-Fluorenone Compound Summary. National Center for Biotechnology Information. Available at: [\[Link\]](#)

Need Custom Synthesis?

BenchChem offers custom synthesis for rare earth carbides and specific isotopic labeling.

Email: info@benchchem.com or [Request Quote Online](#).

Sources

- [1. Fluorenone | C13H8O | CID 10241 - PubChem \[pubchem.ncbi.nlm.nih.gov\]](#)
- [2. youtube.com \[youtube.com\]](#)
- [3. chem.libretexts.org \[chem.libretexts.org\]](#)
- To cite this document: BenchChem. [Mass Spectrometry Fragmentation Patterns of Phenalene-1-one Derivatives]. BenchChem, [2026]. [Online PDF]. Available at: [\[https://www.benchchem.com/product/b1614757/docs#mass-spectrometry-fragmentation-patterns-of-phenalene-1-one-derivatives\]](https://www.benchchem.com/product/b1614757/docs#mass-spectrometry-fragmentation-patterns-of-phenalene-1-one-derivatives)

Disclaimer & Data Validity:

The information provided in this document is for Research Use Only (RUO) and is strictly not intended for diagnostic or therapeutic procedures. While BenchChem strives to provide accurate protocols, we make no warranties, express or implied, regarding the fitness of this product for every specific experimental setup.

Technical Support: The protocols provided are for reference purposes. Unsure if this reagent suits your experiment?

Need Industrial/Bulk Grade? [Request Custom Synthesis Quote](#)

BenchChem

Our mission is to be the trusted global source of essential and advanced chemicals, empowering scientists and researchers to drive progress in science and industry.

Contact

Address: 3281 E Guasti Rd

Ontario, CA 91761, United States

Phone: (601) 213-4426

Email: info@benchchem.com

Contact our Ph.D. Support Team for a compatibility check