

# Scaling up the synthesis of functionalized nitrobenzoates

**Author:** BenchChem Technical Support Team. **Date:** April 2026

## Compound of Interest

Compound Name: *Methyl 3-iodo-4-methyl-5-nitrobenzoate*

CAS No.: 21323-99-9

Cat. No.: B1613463

[Get Quote](#)

Welcome to the Technical Support Center for the Scale-Up Synthesis of Functionalized Nitrobenzoates. This portal is engineered for process chemists, chemical engineers, and drug development professionals transitioning from milligram-scale discovery to multi-kilogram production.

Scaling up nitration and esterification workflows introduces severe mass-transfer, thermodynamic, and safety bottlenecks. This guide synthesizes field-proven troubleshooting logic with rigorous process safety data to ensure your scale-up campaigns are both high-yielding and inherently safe.

## Part 1: Process Safety & Reaction Calorimetry

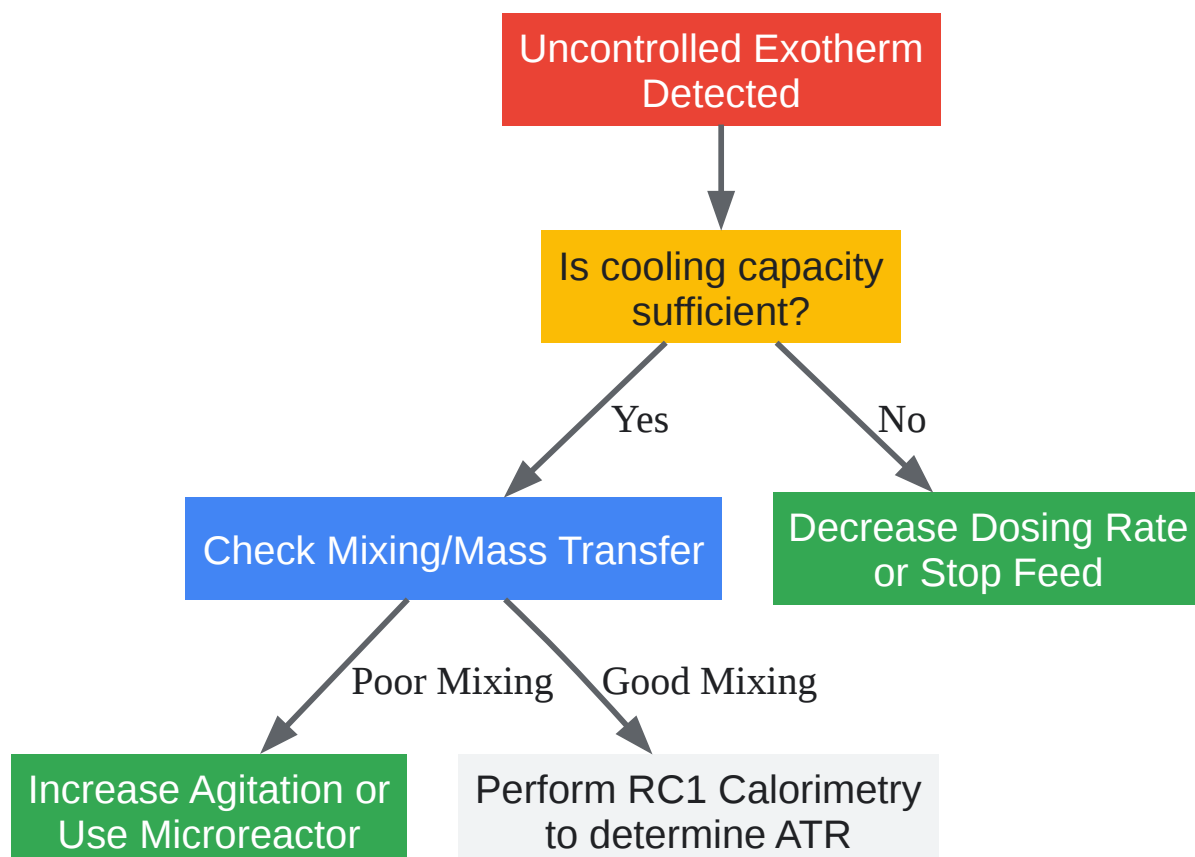

[Click to download full resolution via product page](#)

Decision tree for managing uncontrolled exotherms during scale-up.

## Frequently Asked Questions (FAQs)

Q: Why does my batch nitration of benzoic acid derivatives experience thermal runaway on scale-up, despite being perfectly safe at the lab scale? A: This is a classic thermodynamic scaling issue. At the laboratory scale, the high surface-area-to-volume ratio of small flasks allows for highly efficient heat dissipation. As you scale up to industrial Stirred-Tank Reactors (STRs), the volume of the reaction mass increases cubically while the surface area of the cooling jacket only increases quadratically[1]. This deteriorating ratio severely limits heat transfer. Consequently, the highly exothermic nitration reaction causes localized heating, which accelerates unwanted secondary reactions (e.g., over-nitration) and triggers highly exothermic decomposition of the products, ultimately leading to a thermal runaway or explosion[1].

Q: How do I definitively determine the safe operating temperature for a large-scale nitration? A: You must perform Reaction Calorimetry (using an RC1 calorimeter) to calculate the Adiabatic Temperature Rise (ATR)[2]. The ATR represents the worst-case scenario where cooling fails, and 100% of the reaction enthalpy goes into heating the reaction mass[1]. By adding the ATR to your desired process temperature, you calculate the Maximum Theoretical Reaction Temperature (MTSR). This MTSR must remain well below the Time to Maximum Rate (TD24) and the onset of decomposition (determined by Differential Scanning Calorimetry, DSC) to ensure a safe scale-up window[2].

Q: What is the most effective strategy to mitigate mass-transfer limitations in biphasic nitration? A: Transitioning from batch STRs to continuous-flow microreactors or glass mesoreactors (such as Corning reactors) is the industry standard for process intensification[3][4]. Flow reactors provide exceptional mixing of immiscible fluids and possess a massive specific surface area. This allows for near-instantaneous heat removal and precise control over reaction stoichiometry, thereby suppressing over-nitration and maximizing regioselectivity[5][6].

## Part 2: Troubleshooting Guide

Symptom 1: High levels of dinitrobenzoate byproducts during mono-nitration.

- Root Cause: Poor mixing in batch reactors creates localized concentration gradients of the nitronium ion ( $\text{NO}_2^+$ ), while poor heat transfer creates hot spots. Because the second nitration is highly dependent on activation energy, these hot spots accelerate over-nitration[1][6].

- Resolution: Implement continuous flow using a micromixer. If restricted to batch equipment, decrease the dosing rate of the mixed acid, increase impeller agitation to eliminate gradients, and strictly control the internal temperature ( $\Delta T_r - T_j$ )[2].

Symptom 2: Stalled esterification of nitrobenzoic acids or low yields.

- Root Cause: Fischer esterification is an equilibrium-driven, acid-catalyzed nucleophilic acyl substitution[7]. The accumulation of water as a byproduct shifts the equilibrium back toward the starting carboxylic acid.
- Resolution: For scale-up, operate at temperatures  $>100^\circ\text{C}$  using an entraining solvent (e.g., toluene) to continuously remove liberated water via azeotropic distillation using a Dean-Stark apparatus[8].

## Part 3: Standard Operating Protocols (Self-Validating Systems)

### Protocol A: Continuous-Flow Nitration of Benzoic Acid Derivatives

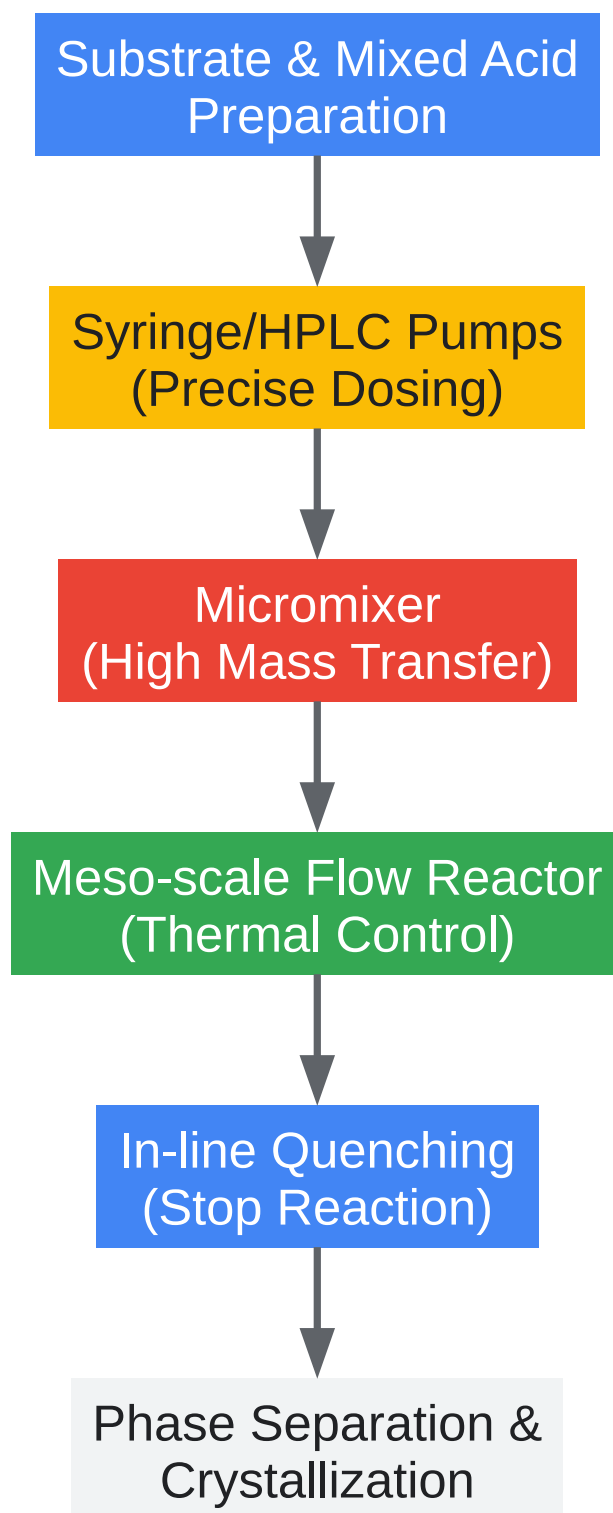

[Click to download full resolution via product page](#)

Continuous flow nitration workflow for functionalized nitrobenzoates.

Step-by-Step Methodology:

- **System Priming:** Prime the high-precision syringe or HPLC pumps with the respective solvent streams to ensure no air bubbles are present, which can disrupt the flow regime and cause dangerous pressure spikes[6].
- **Reagent Preparation:** Prepare Stream A (benzoic acid substrate dissolved in an appropriate organic solvent or sulfuric acid) and Stream B (nitrating agent, typically fuming nitric acid or a mixed acid system)[9].
- **Flow Initiation:** Set the pumps to deliver a specific stoichiometric ratio (e.g., 1.05 to 1.1 equivalents of  $\text{HNO}_3$  to avoid over-nitration)[2][9].
- **Mixing & Reaction:** Direct the streams into a micromixer or a glass mesoreactor maintained at the optimized temperature (e.g.,  $60^\circ\text{C}$ )[3][9]. The residence time is controlled by the total flow rate and reactor volume (typically 30 seconds to a few minutes)[9].
- **In-line Quenching:** Route the reactor effluent directly into a continuous stirred-tank containing ice water or a neutralizing buffer to instantaneously halt the reaction and prevent degradation[3].
- **Validation (IPC):** Continuously monitor the organic phase of the effluent using in-line Process Analytical Technology (PAT) such as Flow-IR, or periodic HPLC sampling, to confirm conversion and regioselectivity.

## Protocol B: Azeotropic Esterification of p-Nitrobenzoic Acid

### Step-by-Step Methodology:

- **Reactor Charging:** To a jacketed reactor equipped with a Dean-Stark trap and reflux condenser, charge p-nitrobenzoic acid, an excess of the target alcohol (e.g., glycerol or ethanol), and an entraining liquid with a boiling point  $>100^\circ\text{C}$  (e.g., toluene)[8].
- **Catalyst Addition:** Add a catalytic amount of a soluble acid catalyst (e.g., concentrated sulfuric acid or p-toluenesulfonic acid)[7][8].
- **Heating & Distillation:** Heat the jacket to bring the reaction mixture to reflux ( $>100^\circ\text{C}$ ). The entraining liquid will form an azeotrope with the liberated water[8].

- **Water Removal:** Continuously drain the separated aqueous layer from the Dean-Stark trap to drive the equilibrium toward the ester[8].
- **Work-up & Validation:** Once HPLC indicates >99% conversion, cool the reactor, neutralize the acid catalyst with aqueous sodium bicarbonate, separate the phases, and concentrate the organic layer under reduced pressure[7].

## Part 4: Quantitative Data & Scale-Up Metrics

Table 1: Comparative Safety and Efficiency Metrics (Batch vs. Flow Nitration)

| Parameter                 | Traditional Batch STR              | Continuous Flow Mesoreactor          | Implication for Scale-Up  |
|---------------------------|------------------------------------|--------------------------------------|---|
| Surface Area/Volume Ratio | < 5 m <sup>2</sup> /m <sup>3</sup> | > 500 m <sup>2</sup> /m <sup>3</sup> | Flow allows rapid heat dissipation, preventing thermal runaway[1][5]. |
| Mixing Efficiency         | Gradient-prone                     | Near-instantaneous                   | Flow prevents local hot spots and over-nitration[6].                  |
| Reaction Time             | Hours                              | Seconds to Minutes                   | Continuous processing increases throughput (e.g., 13 kg/hr ) [3][9].  |
| Exotherm Control          | High risk of ATR exceeding TD24    | Isothermal operation                 | Flow mitigates the risk of explosive decomposition[2][5].             |

Table 2: Calorimetry Data for Aryl Acid Nitration Scale-Up (Adapted from OPRD[2])

| Substrate    | HNO <sub>3</sub> Equivalents | Reaction Time | $\Delta T_r - T_j$ (°C) | Adiabatic Temp Rise (ATR) | TD24 (°C) |
|--------------|------------------------------|---------------|-------------------------|---------------------------|-----------|
| Substrate 2a | 1.30                         | 300 min       | ~3.0                    | 71 °C                     | 234 °C    |
| Substrate 2a | 1.05                         | 600 min       | ~0.0                    | N/A                       | N/A       |
| Substrate 2b | 1.30                         | -             | -                       | 55 °C                     | 243 °C    |

(Note: Decreasing HNO<sub>3</sub> equivalents from 1.30 to 1.05 doubles the reaction time but effectively eliminates the temperature differential ( $\Delta T_r - T_j$ ), drastically improving process safety[2].)

## References

- Managing Hazards for Scale Up of Chemical Manufacturing Processes - ACS Publications. [acs.org](https://acs.org).[\[Link\]](#)
- Hazard Evaluation and Safety Considerations for Scale-Up of a Fuming Nitric Acid Mediated Nitration of Aryl Boronic Acids | Organic Process Research & Development - ACS Publications. [acs.org](https://acs.org).[\[Link\]](#)
- US3948972A - Esterification of nitrobenzoic acids - Google P
- Continuous-flow-enabled intensification in nitration processes: a review of technological developments and practical applications over the past decade - PMC. [nih.gov](https://nih.gov).[\[Link\]](#)
- Simple monitoring of fine chemical runaway reactions in multipurpose plants: the nitration of 2,4-dichloro benzotrifluoride. - Politecnico di Milano. [polimi.it](https://polimi.it).[\[Link\]](#)
- The role of flow in green chemistry and engineering - RSC Publishing. [rsc.org](https://rsc.org).[\[Link\]](#)
- Scale-up and safety of toluene nitration in a meso-scale flow reactor - ResearchGate. [researchgate.net](https://researchgate.net).[\[Link\]](#)
- Reusable ionic liquid-catalyzed oxidative esterification of carboxylic acids with benzylic hydrocarbons via benzylic Csp<sup>3</sup>–H bond activation under metal-free conditions - RSC Publishing. [rsc.org](https://rsc.org).[\[Link\]](#)

- Green Chemistry - RSC Publishing. [rsc.org](https://www.rsc.org).[\[Link\]](#)
- Continuous Flow Synthesis. A Pharma Perspective | Journal of Medicinal Chemistry. [acs.org](https://www.acs.org).  
[\[Link\]](#)
- Antimalarial Preclinical Drug Development: A Single Oral Dose of A 5-Carbon-linked Trioxane Dimer Plus Mefloquine Cures Malaria-Infected Mice - PMC. [nih.gov](https://www.nih.gov).[\[Link\]](#)

### Need Custom Synthesis?

BenchChem offers custom synthesis for rare earth carbides and specific isotopic labeling.

Email: [info@benchchem.com](mailto:info@benchchem.com) or [Request Quote Online](#).

## Sources

- [1. pubs.acs.org](https://pubs.acs.org) [[pubs.acs.org](https://pubs.acs.org)]
- [2. pubs.acs.org](https://pubs.acs.org) [[pubs.acs.org](https://pubs.acs.org)]
- [3. The role of flow in green chemistry and engineering - Green Chemistry \(RSC Publishing\)](#) DOI:10.1039/C3GC40374B [[pubs.rsc.org](https://pubs.rsc.org)]
- [4. pubs.rsc.org](https://pubs.rsc.org) [[pubs.rsc.org](https://pubs.rsc.org)]
- [5. Continuous-flow-enabled intensification in nitration processes: a review of technological developments and practical applications over the past decade - PMC](#) [[pmc.ncbi.nlm.nih.gov](https://pmc.ncbi.nlm.nih.gov)]
- [6. pubs.acs.org](https://pubs.acs.org) [[pubs.acs.org](https://pubs.acs.org)]
- [7. pdf.benchchem.com](https://pdf.benchchem.com) [[pdf.benchchem.com](https://pdf.benchchem.com)]
- [8. US3948972A - Esterification of nitrobenzoic acids - Google Patents](#) [[patents.google.com](https://patents.google.com)]
- [9. researchgate.net](https://researchgate.net) [[researchgate.net](https://researchgate.net)]
- To cite this document: BenchChem. [Scaling up the synthesis of functionalized nitrobenzoates]. BenchChem, [2026]. [Online PDF]. Available at: [<https://www.benchchem.com/product/b1613463/docs#scaling-up-the-synthesis-of-functionalized-nitrobenzoates>]

---

### Disclaimer & Data Validity:

The information provided in this document is for Research Use Only (RUO) and is strictly not intended for diagnostic or therapeutic procedures. While BenchChem strives to provide accurate protocols, we make no warranties, express or implied, regarding the fitness of this product for every specific experimental setup.

**Technical Support:** The protocols provided are for reference purposes. Unsure if this reagent suits your experiment?

**Need Industrial/Bulk Grade?** [Request Custom Synthesis Quote](#)

## BenchChem

Our mission is to be the trusted global source of essential and advanced chemicals, empowering scientists and researchers to drive progress in science and industry.

### Contact

Address: 3281 E Guasti Rd  
Ontario, CA 91761, United States  
Phone: (601) 213-4426  
Email: [info@benchchem.com](mailto:info@benchchem.com)

[Contact our Ph.D. Support Team for a compatibility check](#)