

Microwave-Assisted Synthesis of 5-Chloropyrimidine Derivatives: Application Notes and Protocols

Author: BenchChem Technical Support Team. **Date:** May 2026

Compound of Interest

Compound Name:	Ethyl 5-chloropyrimidine-4-carboxylate
CAS No.:	64224-64-2
Cat. No.:	B1612252

[Get Quote](#)

Abstract

The 5-chloropyrimidine scaffold is a privileged structure in modern medicinal chemistry, forming the core of numerous therapeutic agents, particularly in oncology and virology.[1] Traditional synthetic routes to these vital intermediates often involve prolonged reaction times, harsh conditions, and laborious purification. This guide provides detailed application notes and optimized protocols for the synthesis of 5-chloropyrimidine derivatives utilizing Microwave-Assisted Organic Synthesis (MAOS). By leveraging the unique heating mechanism of microwave irradiation, researchers can achieve dramatic reductions in reaction times, improved yields, and enhanced product purity.[2][3] This document details two key transformations: the direct electrophilic chlorination of pyrimidine precursors and the subsequent functionalization via palladium-catalyzed Suzuki-Miyaura and Sonogashira cross-coupling reactions.

The Science of Microwave-Assisted Synthesis Mechanism of Microwave Heating

Unlike conventional heating methods that transfer energy indirectly via conduction and convection, microwave synthesis relies on the direct interaction of electromagnetic radiation with the molecules in the reaction mixture.[3] This "in-core" heating is primarily driven by two mechanisms:

- **Dipolar Polarization:** Polar molecules, such as the solvents and reagents commonly used in synthesis, possess a dipole moment. When subjected to the oscillating electric field of the microwaves, these molecules attempt to align themselves with the field. This rapid, continuous reorientation creates significant molecular friction, which generates heat efficiently and uniformly throughout the reaction medium.
- **Ionic Conduction:** If ions are present in the reaction mixture (e.g., salts or catalysts), they will migrate back and forth through the solution under the influence of the oscillating electric field. This movement causes collisions with surrounding molecules, and the resistance to this flow dissipates energy as heat.

This direct energy transfer allows for rapid temperature elevation and the ability to reach temperatures far above the solvent's conventional boiling point in a sealed vessel, a phenomenon known as "superheating." [2] This is a key factor in the dramatic rate accelerations observed in microwave-assisted reactions.

Advantages in 5-Chloropyrimidine Synthesis

The application of MAOS to the synthesis of 5-chloropyrimidines and their derivatives offers several compelling advantages over traditional methods:

- **Rapid Reaction Times:** Reactions that typically require many hours or even days of reflux can often be completed in a matter of minutes.[2][4]
- **Higher Yields:** The rapid heating and high temperatures can minimize the formation of side products, leading to cleaner reactions and higher isolated yields.[2]
- **Improved Reproducibility:** Dedicated microwave reactors offer precise control over temperature, pressure, and power, ensuring high reproducibility between runs.
- **Efficient Optimization:** The short reaction times allow for the rapid screening of catalysts, solvents, and bases, significantly accelerating the process of methods development.

Key Synthetic Transformations & Protocols

Direct C-5 Electrophilic Chlorination

The introduction of a chlorine atom at the C-5 position of the pyrimidine ring is a crucial first step for many synthetic pathways. N-Chlorosuccinimide (NCS) is an effective and easy-to-handle electrophilic chlorinating agent for this purpose.^{[1][5]} Microwave irradiation can significantly accelerate this transformation, particularly with activated pyrimidine substrates.

Causality Behind Experimental Choices: The choice of a polar, high-boiling solvent like N,N-Dimethylformamide (DMF) is strategic. Its high dielectric constant ensures efficient absorption of microwave energy, leading to rapid heating. Furthermore, its high boiling point allows the reaction to be conducted at elevated temperatures safely, which is necessary to overcome the activation energy for the electrophilic substitution on the pyrimidine ring.

Protocol 1: Microwave-Assisted C-5 Chlorination of a Pyrimidine Precursor

- **Vessel Preparation:** To a 10 mL microwave process vial equipped with a magnetic stir bar, add the pyrimidine starting material (1.0 mmol, 1.0 equiv).
- **Reagent Addition:** Add N-Chlorosuccinimide (NCS) (1.1 mmol, 1.1 equiv) and 3-5 mL of anhydrous DMF.
- **Sealing:** Securely seal the vial with a Teflon septum and an aluminum crimp cap.
- **Microwave Irradiation:** Place the vial into the cavity of a dedicated laboratory microwave reactor. Irradiate the mixture at 120-140 °C for 10-20 minutes. The reaction power should be set to automatically adjust to maintain the target temperature.
- **Cooling:** After irradiation is complete, allow the vial to cool to below 50 °C using the instrument's compressed air cooling feature before carefully removing it from the microwave cavity.
- **Work-up & Purification:** Quench the reaction mixture by pouring it into ice-water (50 mL). The crude product may precipitate and can be collected by vacuum filtration. If it remains in solution, extract with an organic solvent such as ethyl acetate (3 x 20 mL). Wash the combined organic layers with water and brine, dry over anhydrous sodium sulfate (Na₂SO₄),

filter, and concentrate under reduced pressure. Purify the crude residue by column chromatography on silica gel.

Substrate Example	Reagent	Solvent	Temperature (°C)	Time (min)	Typical Yield (%)
2-Aminopyrimidine	NCS	DMF	130	15	75-85
Uracil	NCS	Acetic Acid	140	20	70-80
2,4-Dimethoxyimidine	NCS	Acetonitrile	120	10	85-95

Table 1: Representative conditions for microwave-assisted C-5 chlorination.

Palladium-Catalyzed Cross-Coupling Reactions

The C-Cl bond on the electron-deficient pyrimidine ring is an excellent handle for palladium-catalyzed cross-coupling reactions, enabling the formation of C-C bonds and the rapid construction of diverse molecular libraries.

The Suzuki-Miyaura reaction is one of the most powerful methods for forming biaryl or aryl-heteroaryl bonds. Microwave assistance has been shown to facilitate this reaction with chloropyrimidines, often with very low catalyst loadings and extremely short reaction times.^[4]^[6]

Causality Behind Experimental Choices: The use of a palladium catalyst like Tetrakis(triphenylphosphine)palladium(0) [Pd(PPh₃)₄] is standard for Suzuki couplings.^[4]^[7] A mixed solvent system, such as 1,4-dioxane and water, is often optimal; the organic solvent solubilizes the pyrimidine and catalyst, while the aqueous phase dissolves the inorganic base (e.g., K₂CO₃), creating a biphasic system where the reaction proceeds efficiently at the interface. Microwave heating excels at rapidly heating such biphasic mixtures.

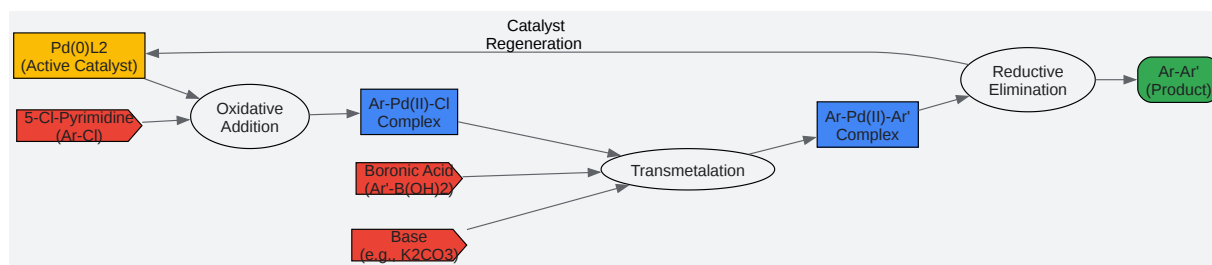

[Click to download full resolution via product page](#)

Suzuki-Miyaura Catalytic Cycle.

Protocol 2: Microwave-Assisted Suzuki-Miyaura Coupling

- **Vessel Preparation:** To a 10 mL microwave process vial equipped with a magnetic stir bar, add the 5-chloropyrimidine derivative (1.0 mmol, 1.0 equiv), the arylboronic acid (1.2 mmol, 1.2 equiv), and potassium carbonate (K_2CO_3) (2.0 mmol, 2.0 equiv).
- **Catalyst Addition:** Add Tetrakis(triphenylphosphine)palladium(0) [$Pd(PPh_3)_4$] (0.01-0.05 mmol, 1-5 mol%). For less reactive chlorides, a higher catalyst loading may be beneficial.
- **Solvent Addition:** Add a degassed mixture of 1,4-dioxane and water (e.g., 4 mL dioxane, 1 mL H_2O).
- **Sealing & Irradiation:** Seal the vial and place it in the microwave reactor. Irradiate the mixture at 100-150 °C for 5-20 minutes.
- **Cooling & Work-up:** After cooling, dilute the reaction mixture with ethyl acetate (20 mL) and water (20 mL). Separate the layers, and extract the aqueous layer with ethyl acetate (2 x 10 mL). Combine the organic layers, wash with brine, dry over Na_2SO_4 , and concentrate.
- **Purification:** Purify the crude product by column chromatography on silica gel.

5-Chloropyrimidine Substrate	Boronic Acid	Catalyst (mol%)	Temp (°C)	Time (min)	Typical Yield (%)	Reference
2-Amino-5-chloropyrimidine	Phenylboronic acid	Pd(PPh ₃) ₄ (2%)	120	15	92	[4]
5-Chloro-2,4-dimethoxypyrimidine	4-Methoxyphenylboronic acid	Pd(PPh ₃) ₄ (1%)	110	10	95	Adapted from [4]
5-Chloropyrimidine	Thiophene-2-boronic acid	Pd(PPh ₃) ₄ (3%)	130	15	88	Adapted from [8]

Table 2: Representative conditions for microwave-assisted Suzuki-Miyaura coupling.

The Sonogashira coupling provides a powerful route to synthesize alkynyl-substituted pyrimidines, which are valuable precursors in drug discovery.[9] The reaction couples a terminal alkyne with an aryl halide, catalyzed by palladium and typically a copper(I) co-catalyst. Microwave heating dramatically accelerates this process.[10][11]

Causality Behind Experimental Choices: This reaction requires a palladium catalyst for the main cycle and often a copper(I) salt (e.g., CuI) as a co-catalyst to facilitate the formation of a copper acetylide intermediate, which speeds up the transmetalation step. An amine base, such as triethylamine (Et₃N) or diisopropylethylamine (DIPEA), is crucial as it serves both as the base to deprotonate the alkyne and often as the solvent. These amines are polar enough to heat effectively under microwave irradiation.

Protocol 3: Microwave-Assisted Sonogashira Coupling

- Vessel Preparation: To an oven-dried 10 mL microwave process vial with a stir bar, add the 5-chloropyrimidine derivative (1.0 mmol, 1.0 equiv).

- **Catalyst Addition:** Add Bis(triphenylphosphine)palladium(II) dichloride [$\text{PdCl}_2(\text{PPh}_3)_2$] (0.03 mmol, 3 mol%) and Copper(I) iodide (CuI) (0.06 mmol, 6 mol%).
- **Solvent and Reagent Addition:** Add 4 mL of anhydrous, degassed triethylamine (Et_3N) followed by the terminal alkyne (1.5 mmol, 1.5 equiv).
- **Sealing & Irradiation:** Seal the vial and place it in the microwave reactor. Irradiate the mixture at 100-140 °C for 15-30 minutes.
- **Cooling & Work-up:** After cooling, dilute the reaction mixture with ethyl acetate and filter through a pad of celite to remove catalyst residues. Wash the filtrate with saturated aqueous NH_4Cl solution, then with brine.
- **Purification:** Dry the organic layer over Na_2SO_4 , concentrate, and purify by column chromatography on silica gel.

5-Chloropyrimidine Substrate	Alkyne	Temp (°C)	Time (min)	Typical Yield (%)	Reference
5-Chloropyrimidine	Phenylacetylene	120	20	85	Adapted from[10][11]
2-Amino-5-chloropyrimidine	Trimethylsilyl acetylene	100	25	90	Adapted from[10]
5-Chloro-4-methylpyrimidine	1-Hexyne	130	15	88	Adapted from[12]

Table 3: Representative conditions for microwave-assisted Sonogashira coupling.

Experimental Workflow and Safety Considerations

A dedicated microwave reactor designed for chemical synthesis is mandatory for these protocols. Domestic kitchen microwave ovens must not be used, as they lack the necessary temperature/pressure controls and safety features to handle flammable solvents and pressurized reactions.

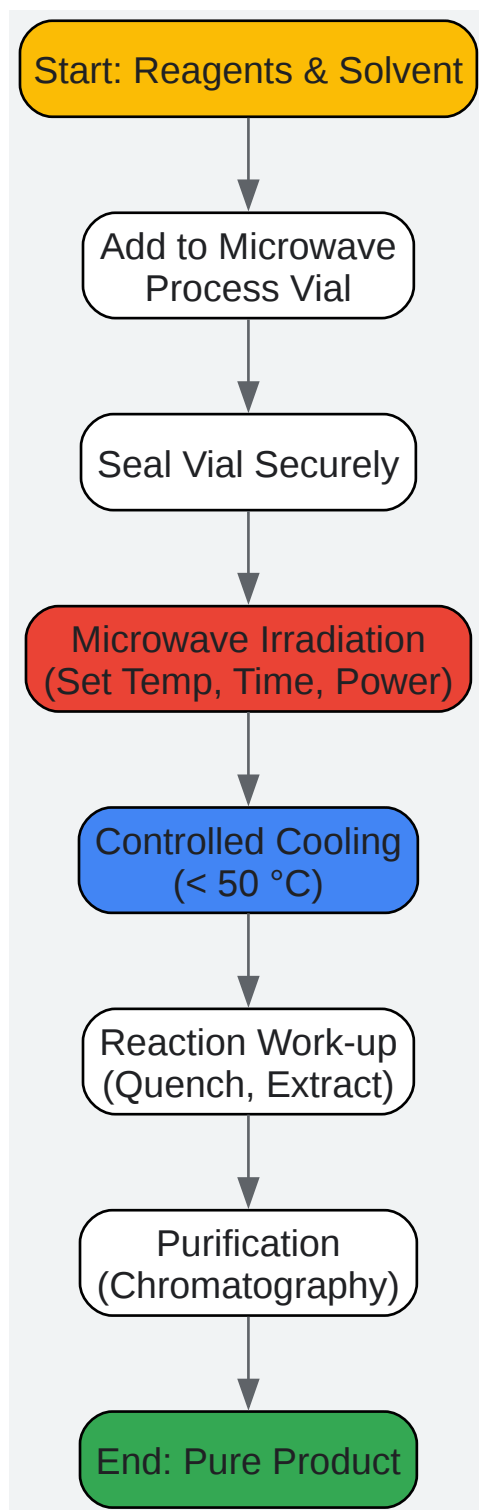

[Click to download full resolution via product page](#)

General Microwave Synthesis Workflow.

Safety Precautions:

- **Pressure Management:** Reactions are performed in sealed vessels and will generate significant internal pressure. Always use vials and caps rated for the temperatures and pressures expected. Never exceed the recommended fill volume for the vial (typically 1/3 to 1/2 full).
- **Cooling:** Ensure the reaction vessel has cooled to a safe temperature (well below the solvent's boiling point at atmospheric pressure) before opening.
- **Personal Protective Equipment (PPE):** Always wear safety glasses, a lab coat, and appropriate gloves. Conduct all operations within a well-ventilated fume hood.
- **Catalyst Handling:** Palladium catalysts are toxic and should be handled with care.

Conclusion

Microwave-assisted synthesis is a transformative technology for accelerating the discovery and development of novel 5-chloropyrimidine derivatives. The protocols outlined in this guide demonstrate that MAOS can dramatically reduce reaction times from hours to minutes while often improving yields for key transformations like chlorination, Suzuki-Miyaura coupling, and Sonogashira coupling. By understanding the principles of microwave heating and adhering to proper safety protocols, researchers can effectively harness this powerful tool to advance their drug discovery programs.

References

- Leadbeater, N. E., & McGowan, C. (2006). Open-Vessel Microwave-Promoted Suzuki Reactions Using Low Levels of Palladium Catalyst: Optimization and Scale-Up. *Organic Process Research & Development*. Available at: [\[Link\]](#)
- Knez, D., et al. (2021). Microwave-Assisted Regioselective Suzuki Coupling of 2,4-Dichloropyrimidines with Aryl and Heteroaryl Boronic Acids. *Molecules*. Available at: [\[Link\]](#)

- Baxendale, I. R., et al. (2006). Microwave-Assisted Suzuki Coupling Reactions with an Encapsulated Palladium Catalyst for Batch and Continuous-Flow Transformations. *Chemistry – A European Journal*. Available at: [\[Link\]](#)
- dos Santos, J. C. S., et al. (2013). An Efficient Microwave-Assisted Suzuki Reaction using a New Pyridine-Pyrazole/Pd(II) Species as Catalyst in Aqueous Media. *Molecules*. Available at: [\[Link\]](#)
- Hopkins, J. M., & Collar, N. (2004). Sonogashira/Heteroannulation Strategies. *Organic Chemistry Portal*. Available at: [\[Link\]](#)
- Prasanna Kumara, B. N., et al. (2013). Synthesis, characterization, and in vitro antimicrobial evaluation of new 5-chloro-8-bromo-3-aryl-1,2,4-triazolo[4,3-c]pyrimidines. *Medicinal Chemistry Research*.
- Verbitskiy, E. V., et al. (2018). Recent Approaches to the Synthesis of Medicinally Potent Pyrimidine Derivatives using Microwave: A Review. *International Journal of Management, Technology And Engineering*. Available at: [\[Link\]](#)
- Martins, C. F., et al. (2024). Microwave-Assisted Solvent- and Cu(I)-Free Sonogashira C-C Cross-Coupling Catalysed by Pd Ionanofluids. *Processes*. Available at: [\[Link\]](#)
- Antermite, D., et al. (2025). An Efficient Synthesis of 3,5-Bis-Aminated Pyrazolo[1,5-a]Pyrimidines: Microwave-Assisted Copper Catalyzed C-3 Amination of 5-Amino-3-Bromo-Substituted Precursors. *Molecules*. Available at: [\[Link\]](#)
- Organic Chemistry Portal. N-Chlorosuccinimide (NCS). Available at: [\[Link\]](#)
- Filyakova, T. V., et al. (2022). New Derivatives of 5-Substituted Uracils: Potential Agents with a Wide Spectrum of Biological Activity. *Pharmaceuticals*. Available at: [\[Link\]](#)
- Nagy, N. M., et al. (2025). Synergy in Sonogashira Cross-Coupling Reactions with a Magnetic Janus-Type Catalyst. *Catalysts*. Available at: [\[Link\]](#)
- Sahoo, S. K., et al. (2023). Reaction Environment Design for Multigram Synthesis via Sonogashira Coupling over Heterogeneous Palladium Single-Atom Catalysts. *ACS Catalysis*. Available at: [\[Link\]](#)

- Solanki, A., & Singh, R. (2015). Chlorination of Aromatic Compounds in Aqueous Media using N- Chlorosuccinimide. Research Journal of Chemical Sciences. Available at: [\[Link\]](#)
- Wikipedia. N-Chlorosuccinimide. Available at: [\[Link\]](#)
- Trilleras, J., et al. (2010). Efficient Microwave-Assisted Synthesis of 5-Deazaflavine Derivatives. Molecules. Available at: [\[Link\]](#)
- Mu, S., et al. (2024). Design, synthesis, and biological evaluation of 5-chlorine-2-amino-pyrimidine derivatives as potent PLK4 inhibitors. RSC Medicinal Chemistry. Available at: [\[Link\]](#)
- Herrero, M. A., et al. (2007). Efficient microwave-assisted Suzuki–Miyaura cross-coupling reaction of 3-bromo pyrazolo[1,5-a]pyrimidin-5(4H). Tetrahedron. Available at: [\[Link\]](#)
- Martins, C. F., et al. (2024). Microwave-Assisted Solvent- and Cu(I)-Free Sonogashira C-C Cross-Coupling Catalysed by Pd Ionanofluids. MDPI. Available at: [\[Link\]](#)
- Knez, D., et al. (2021). Microwave-Assisted Regioselective Suzuki Coupling of 2,4-Dichloropyrimidines with Aryl and Heteroaryl Boronic Acids. MDPI. Available at: [\[Link\]](#)
- Wilson, M. W., et al. (2001). Microwave-assisted acylation of 7-amino-5-aryl-6-cyanopyrido[2,3-d]pyrimidines. Tetrahedron Letters. Available at: [\[Link\]](#)
- Yadav, A. R., et al. (2020). Microwave assisted synthesis of some Traditional reactions: Green chemistry approach. GSC Biological and Pharmaceutical Sciences. Available at: [\[Link\]](#)
- Vaghasia, S. J., & Shah, V. H. (2007). Microwave assisted synthesis and antimicrobial activity of some novel pyrimidine derivatives. Journal of the Serbian Chemical Society. Available at: [\[Link\]](#)
- Maggini, M., et al. (2012). Efficient Synthesis and Microwave-Assisted Sonogashira Reactions of Triflate-Substituted Porphyrin. European Journal of Organic Chemistry. Available at: [\[Link\]](#)
- de la Torre, V., et al. (2020). Ultrasound-assisted synthesis of pyrimidines and their fused derivatives: A review. Beilstein Journal of Organic Chemistry. Available at: [\[Link\]](#)

- Satyanarayana, V. S. V., et al. (2014). Microwave-Assisted Synthesis of 2,4,5-Triphenyl-1H-imidazole Containing Schiff Base Derivatives with Potential Antioxidant and Anticancer Activities. Asian Journal of Chemistry. Available at: [[Link](#)]

Need Custom Synthesis?

BenchChem offers custom synthesis for rare earth carbides and specific isotopic labeling.

Email: info@benchchem.com or [Request Quote Online](#).

Sources

- 1. pdf.benchchem.com [pdf.benchchem.com]
- 2. pdf.benchchem.com [pdf.benchchem.com]
- 3. ajrconline.org [ajrconline.org]
- 4. pdfs.semanticscholar.org [pdfs.semanticscholar.org]
- 5. N-Chlorosuccinimide - Wikipedia [en.wikipedia.org]
- 6. mdpi.com [mdpi.com]
- 7. benchchem.com [benchchem.com]
- 8. pdf.benchchem.com [pdf.benchchem.com]
- 9. pdf.benchchem.com [pdf.benchchem.com]
- 10. Microwave Chemistry: Hiyama Couplings, Sonogashira/Heteroannulation, β -Glycosylamine Synthesis, 4-Thiazolidinones, Click Chemistry [organic-chemistry.org]
- 11. psecommunity.org [psecommunity.org]
- 12. mdpi.com [mdpi.com]
- To cite this document: BenchChem. [Microwave-Assisted Synthesis of 5-Chloropyrimidine Derivatives: Application Notes and Protocols]. BenchChem, [2026]. [Online PDF]. Available at: [<https://www.benchchem.com/product/b1612252/docs#microwave-assisted-synthesis-of-5-chloropyrimidine-derivatives-application-notes-and-protocols>]

Disclaimer & Data Validity:

The information provided in this document is for Research Use Only (RUO) and is strictly not intended for diagnostic or therapeutic procedures. While BenchChem strives to provide accurate protocols, we make no warranties, express or implied, regarding the fitness of this product for every specific experimental setup.

Technical Support: The protocols provided are for reference purposes. Unsure if this reagent suits your experiment?

Need Industrial/Bulk Grade? [Request Custom Synthesis Quote](#)

BenchChem

Our mission is to be the trusted global source of essential and advanced chemicals, empowering scientists and researchers to drive progress in science and industry.

Contact

Address: 3281 E Guasti Rd
Ontario, CA 91761, United States
Phone: (601) 213-4426
Email: info@benchchem.com

[Contact our Ph.D. Support Team for a compatibility check](#)